



FR
Pensez à
donner ou recycler.



Association

ou



Magasin

ou



Déchèterie

<https://quefairedemesdechets.fr>



LE TRI
+ FACILE



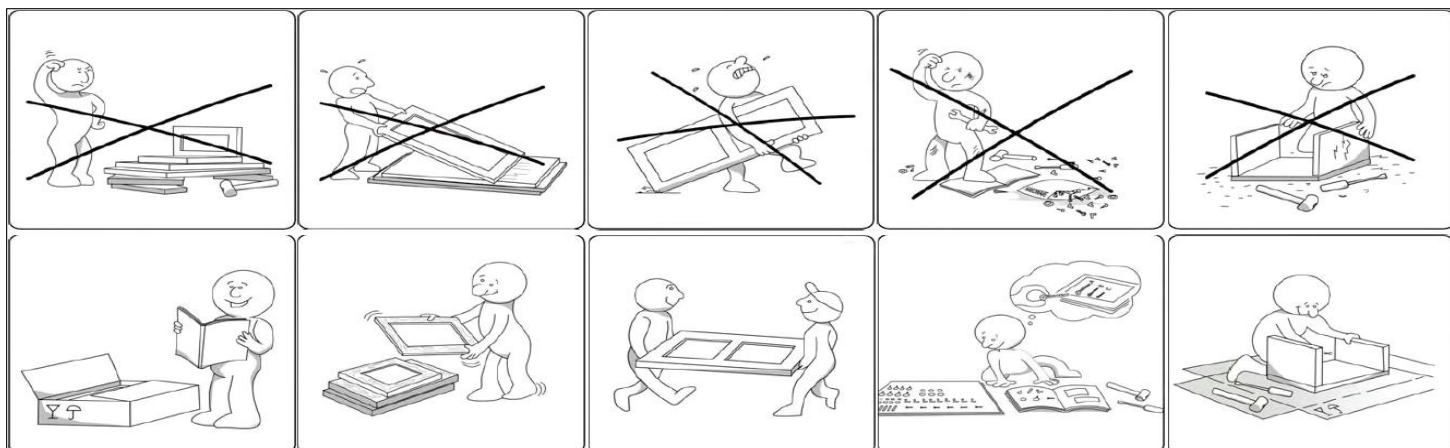

FR

CONSIGNES DE SECURITE

IMPORTANT ! À LIRE ATTENTIVEMENT ET À CONSERVER EN VUE D'UNE CONSULTATION ULTÉRIEURE

1:Ce meuble est à usage domestique.

2:A monter soi-même.

Vérifier la présence et l'état de la quincaillerie et des pièces avant de débuter le montage.

Ne pas monter ou utiliser le mobilier si certains éléments sont cassés, endommagés ou manquants, et n'utiliser que des pièces approuvées par le fabricant. Utiliser uniquement l'outillage fourni ou préconisé.

Serrer correctement les éléments de fixation avec l'outillage fourni ou préconisé.

Un mauvais montage, calage ou manutention peut entraîner une fragilisation des assemblages et/ou des pièces.

Tenir éloigné les jeunes enfants lors de l'assemblage. Présence de petites pièces susceptibles d'être ingérées.

Il convient que tous les dispositifs d'assemblage soient toujours convenablement serrés et régulièrement vérifiés, et resserrés, si nécessaire.

Ne pas déplacer un mobilier chargé.

3:ATTENTION ! Ne pas utiliser ce siège pour des personnes souffrant d'un handicap physique et nécessitant la position assise continue et fréquente.

ATTENTION ! Ce siège ne doit être utilisé que dans le cadre du loisir ou de la relaxation. Ce siège ne répond pas aux normes en vigueur du mat ériel médical.

EN

SAFETY INFORMATION

IMPORTANT ! READ CAREFULLY AND KEEP FOR FUTURE REFERENCE

1:This furniture is for domestic use.

2:Self-assembly required.

Check that all of the hardware and parts are present and in good condition before starting assembly.

Do not assemble or use the furniture if any of the parts are broken, damaged or missing, and only use parts approved by the manufacturer.

Only use tools that are supplied or recommended.

Firmly tighten the fasteners using the supplied or recommended tools.

Improper assembly, cribbing or handling can lead to assemblies and/or parts becoming weakened.

Keep young children away during assembly. The product contains small parts that could be ingested.

All joints should always be properly tightened and regularly checked, and retightened, if necessary.

Do not move furniture that is loaded.

3:WARNING! Do not use this seat for people suffering of a physical handicap, and needing a seated continue and frequent position.



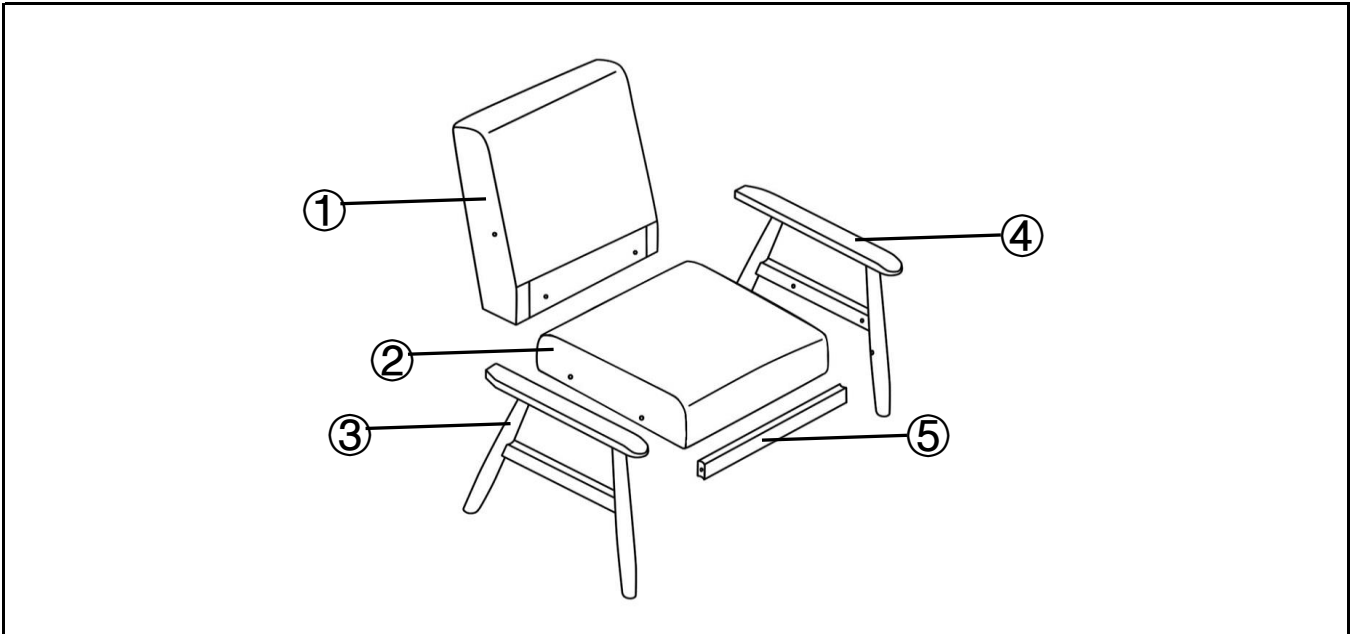



WARNING! This product shall be used in a frame of leisure or relaxation. This product does not comply with the norms in force for medical material.



	NON FOURNI(S) NOT INCLUDED		2		10 MIN
---	-------------------------------	---	----------	---	-----------

No.	TAILLE SIZE	QTE QTY	CTN No.	⑤	535*25*50mm	x 1	1	⑩				⑮			
①	540*610*140mm	x 1	1	⑥				⑪				⑯			
②	520*520*140mm	x 1	1	⑦				⑫							
③	590*535*60mm	x 1	1	⑧				⑬							
④	590*535*60mm	x 1	1	⑨				⑭							

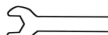



Quincaillerie de montage / Hardware

A x 10	B x 8	C x 8	D x 10	E x 2	F x 1	G x 4
						
M6x65mm	M6	Ø16/Ø6x1.8mm	M6	M6	M10	M6





1

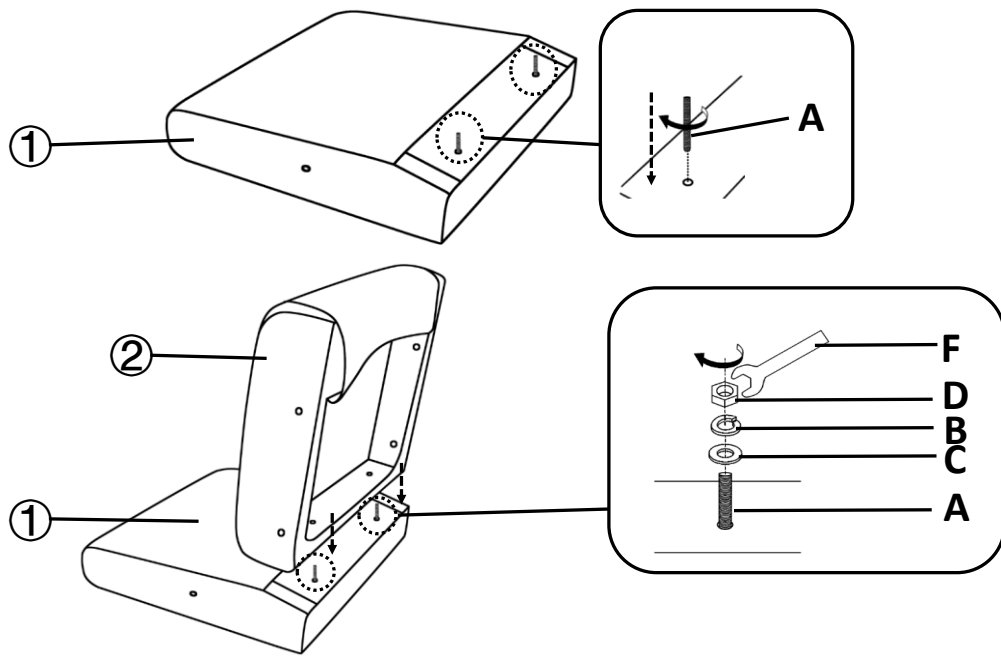

A x 2

M6x65mm
B x 2

M6
C x 2

Ø16/Ø6x1.8mm
D x 2

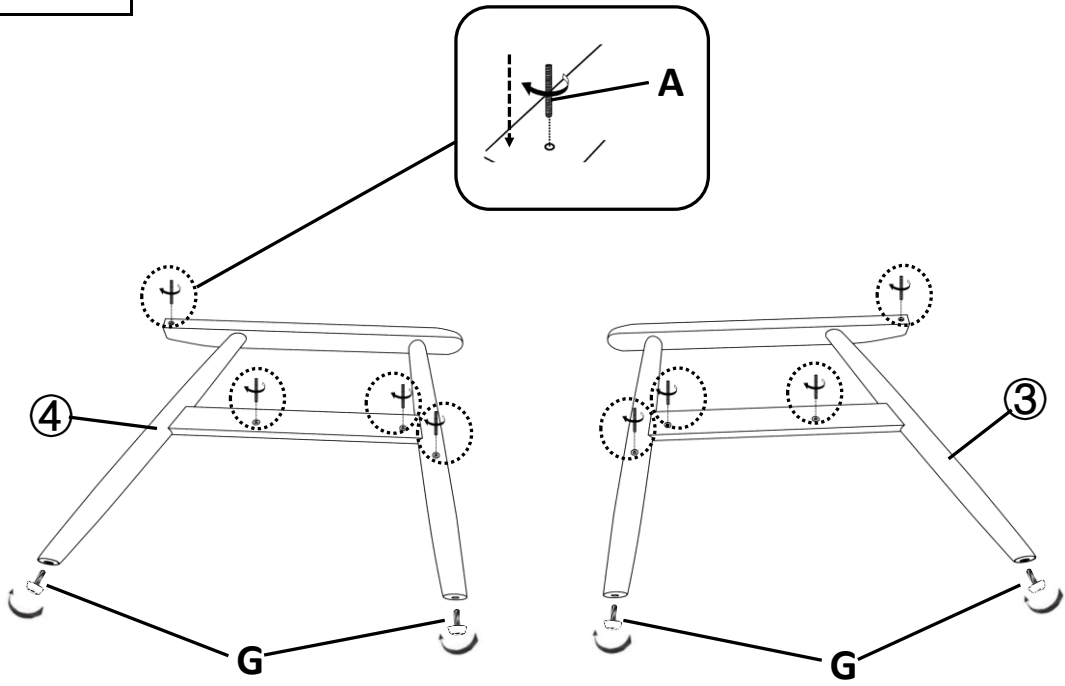
M6
F x 1

M10







2

A x 8

M6x65mm
G x 4

M6



3

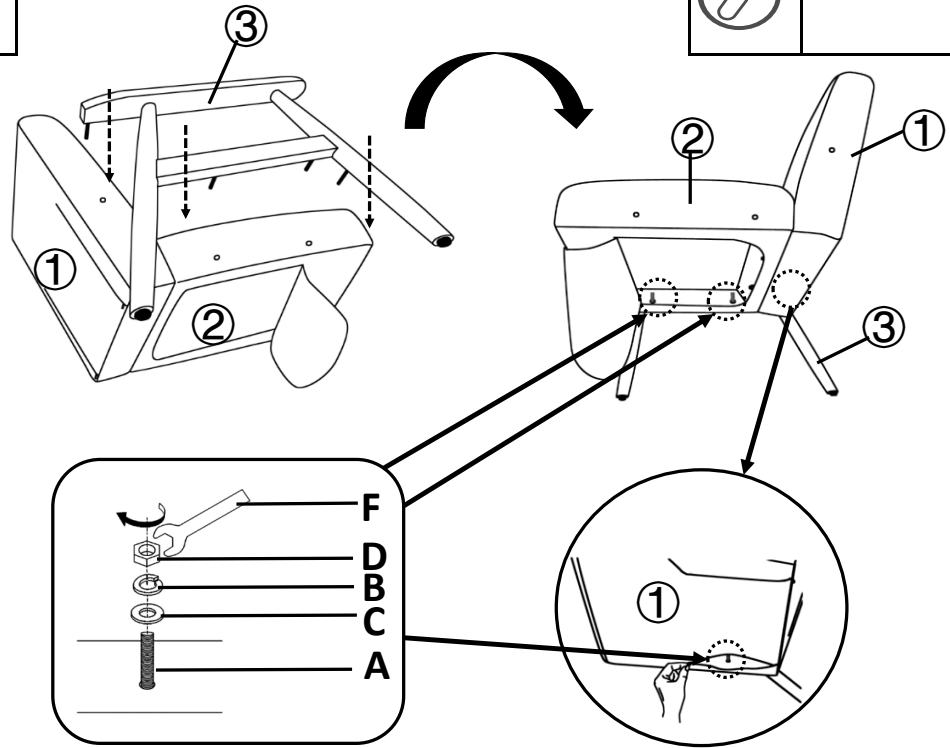



- B** x 3

M6
- C** x 3

Ø16/Ø6x1.8mm
- D** x 3

M6
- F** x 1

M10

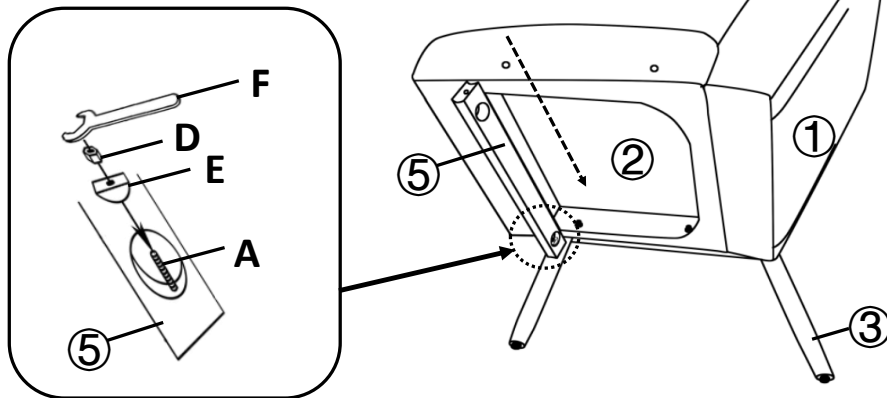

4



- D** x 1

M6
- E** x 1

M6
- F** x 1

M10

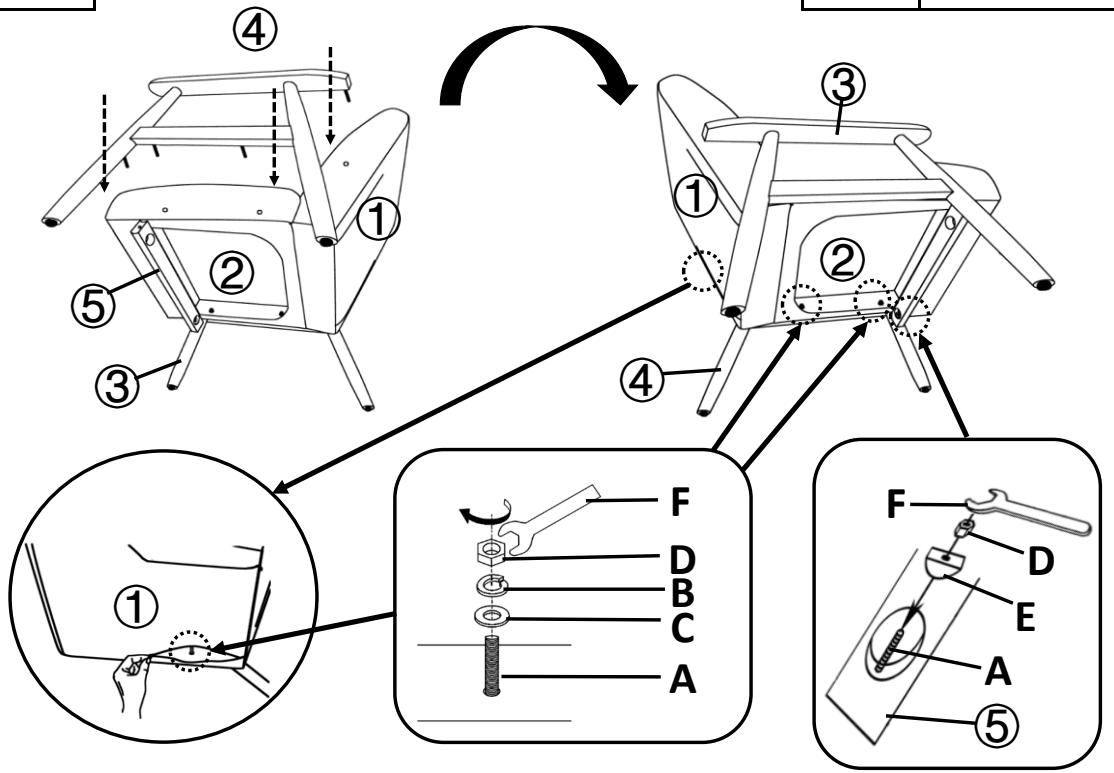

5



B x 3
M6
C x 3
Ø16/Ø6x1.8mm
D x 4
M6
E x 1
M6
F x 1
M10



6

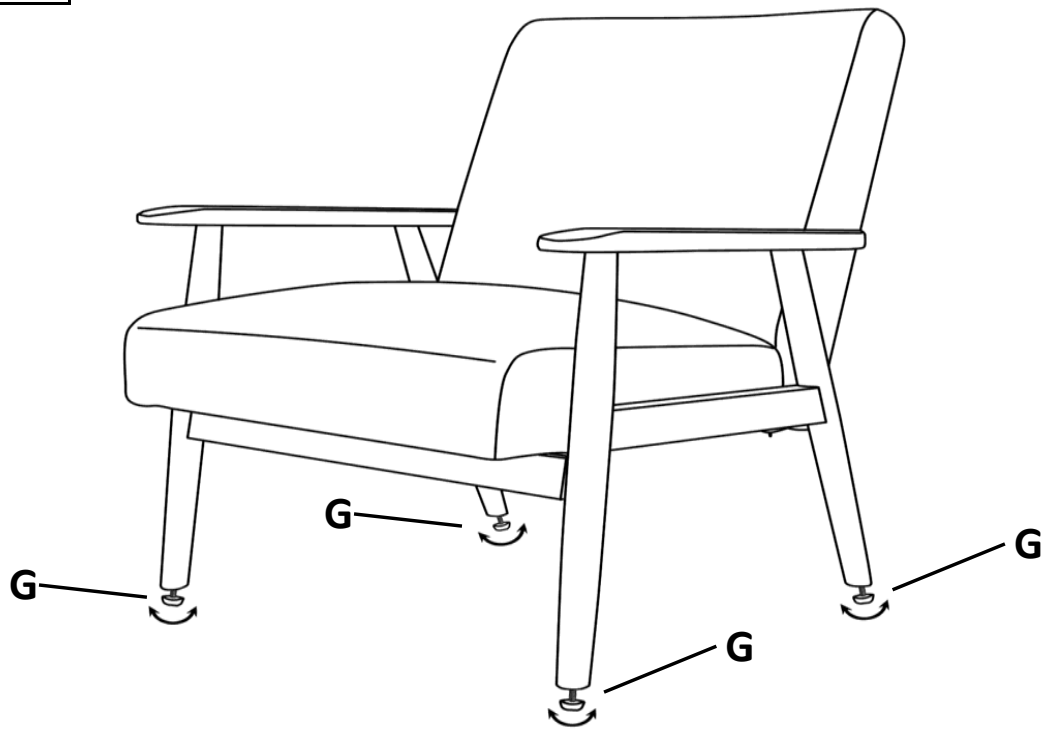

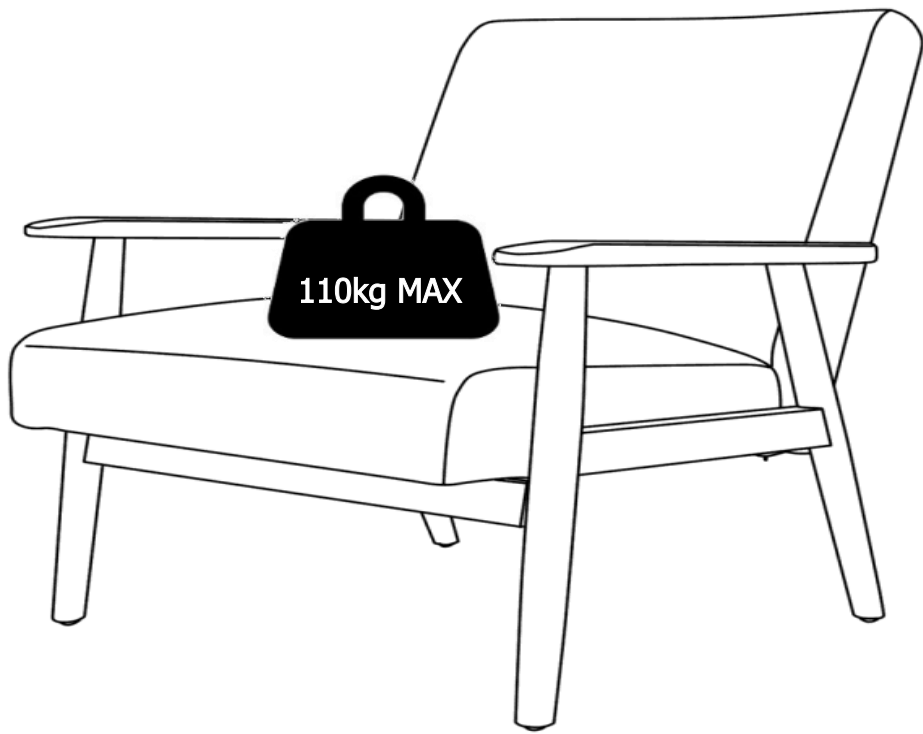

CHARGE MAXIMALE
MAXIMUM LOAD

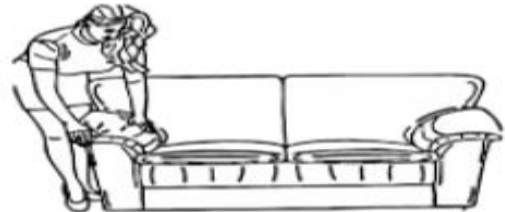
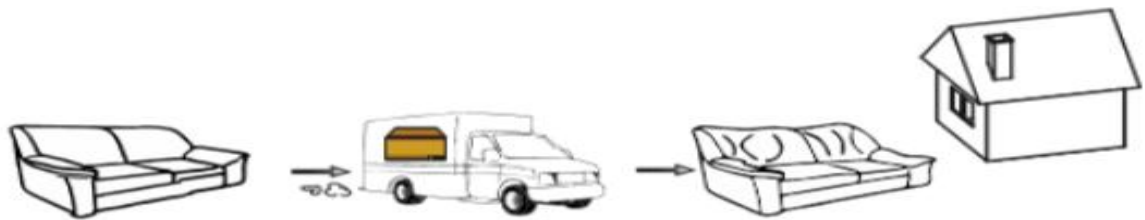

FR

CONSIGNES D'UTILISATION	<p>1: Ne jamais forcer les assemblages. Resserrez les vis après quelques temps d'usage. Gardez votre notice de montage, si une pièce venait à manquer, elle serait le plus clair moyen de communiquer avec votre magasin.</p> <p>2: Respecter la charge maximale pour une utilisation sécurisée.</p> <p>3: Un siège relax classique peut se mettre contre un mur. Néanmoins, il est nécessaire de prévoir à minima 0,3 m de distance avec ce dernier afin de pouvoir déployer votre siège correctement.</p>
--------------------------------	---

RANGEMENT ET ENTRETIEN	<p>1: Un canapé changera tout naturellement de forme et d'aspect sous l'effet de l'affaissement ou du déplacement du rembourrage dans le temps. Afin de prolonger le gonflant de votre canapé et de répartir l'usure de façon régulière, il est fortement conseillé :</p> <ul style="list-style-type: none">• De retourner régulièrement les coussins si cela est possible.• De relisser la surface des assises immédiatement après une utilisation prolongée et de masser les coussins pour leur redonner du gonflant. <p>2: Le tissu de votre canapé aura une tendance naturelle à boulocher. Ceci n'est pas un défaut dès lors que :</p> <ul style="list-style-type: none">• Les bouloches peuvent facilement être enlevées ou s'estompent avec le temps.• Le nombre de bouloches n'affecte pas sensiblement l'esthétique de votre produit. - Only for fabric product. <p>3: Dépoussiérer soigneusement puis humecter un chiffon doux et propre d'eau légèrement savonneuse. Ne pas utiliser de produits de nettoyage abrasifs ou solvants.</p>
-------------------------------	--

EN

INSTRUCTIONS FOR USE	<p>1: Never force the connections. Re-tighten the screws after few days. Keep the Instructions AI leaflet, it contains information when claiming for missing parts.</p> <p>2: Ensure to not exceed the maximum loading weight for a safe usage.</p> <p>3: Classic relax seat can be placed against a wall. Nevertheless, it is necessary to provide at least 0.3 m distance with it in order to be able to deploy your seat correctly.</p>
-----------------------------	--

STORAGE AND CLEANING	<p>1: A seat will naturally change shape and appearance as the padding sags or shifts over time. In order to prolong the shape of your product and evenly distribute wear, it is strongly recommended:</p> <ul style="list-style-type: none">• Turn the cushions over regularly, if possible,• Pilling can easily be removed or fade over time,• To smooth the surface of the seats immediately after prolonged use and to massage the cushions to restore their swelling. <p>2: Your seat fabric will have a natural tendency to pill. This is not a defect if:</p> <ul style="list-style-type: none">• The number of pills does not significantly affect the aesthetics of your product. - Only for fabric product. <p>3: Carefully remove the dust. Use a soft and clean damp cloth with soapy water. Do not use abrasive cleaning products or solvents.</p>
-----------------------------	---