

Installationsanleitung/Installation Instruction/Instruction d'installation  
Istruzioni di installazione/Instrucciones de instalación  
Installatie-instructies/Installationsanvisningar/Instrukcje instalacji  
KÜCHENWAGEN-N620P382328/N620P382329/N620P382330  
KITCHEN CART-N639P382386/N639P382387/N639P382388

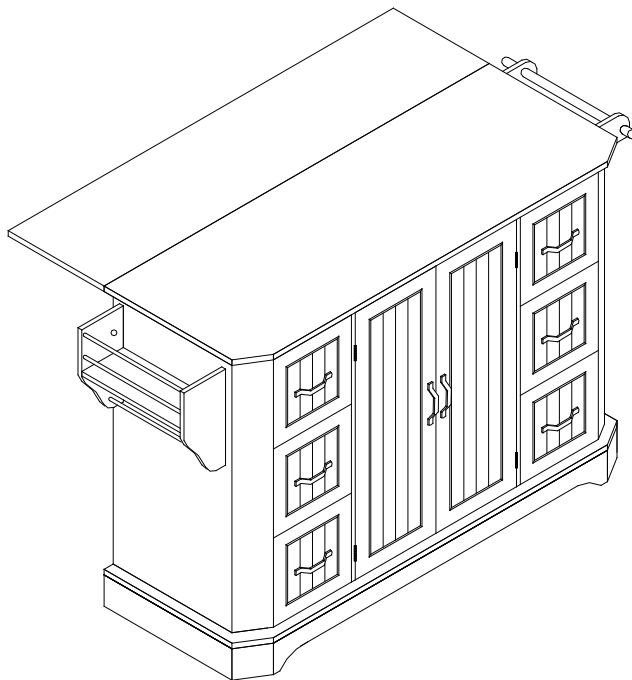

DE: Unser Produkt wird Ihnen in 3 Paketen geliefert. Die Lieferzeiten dieser 3 Pakete können abweichen, bitte haben Sie etwas Geduld und vielen Dank für Ihr Verständnis.

UK: Our product will be delivered to you in 3 packages. The delivery times of these 3 packages may differ, please be patient and thank you for your understanding.

FR: Notre produit vous sera livré en 3 colis. Les délais de livraison de ces 3 colis peuvent différer, soyez patient et merci pour votre compréhension.

IT: Il nostro prodotto verrà consegnato in 3 pacchi. I tempi di consegna di questi 3 pacchi possono variare; vi preghiamo di avere un po' di pazienza e vi ringraziamo per la vostra comprensione.

ES: Nuestro producto se entregará en 3 paquetes. Los tiempos de entrega de estos 3 paquetes pueden variar; por favor, tenga un poco de paciencia y gracias por su comprensión.

Installatie-instructies/Installationsanvisningar/Instrukcje instalacji

NL: Ons product wordt in 3 pakketten bij u geleverd. De levertijden van deze 3 pakketten kunnen verschillen, we vragen om uw geduld en bedanken u voor uw begrip.

SE: Vår produkt kommer att levereras till dig i 3 paket. Leveranstiderna för dessa 3 paket kan variera, vi ber om ditt tålamod och tackar för din förståelse.

PL: Nasz produkt zostanie dostarczony w 3 paczkach. Czas dostawy tych 3 paczek może się różnić, prosimy o cierpliwość i dziękujemy za zrozumienie.

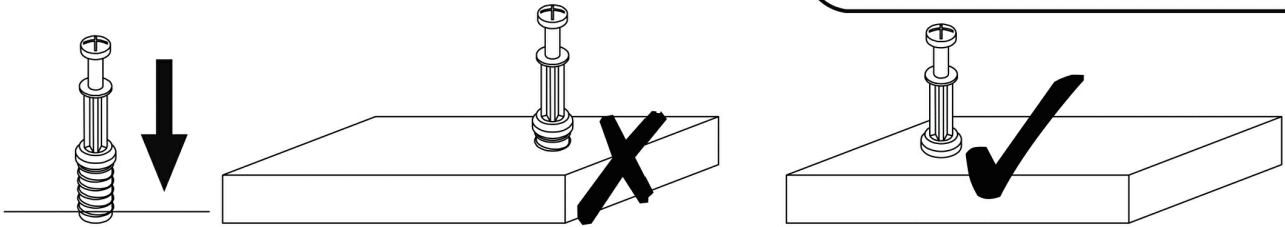

**EN\_QUICKFIT:** Tighten quickfit until shoulder is flush with panel. Do not overtighten or undertighten.

**FR\_RACCORD RAPIDE:** Faites serrer le raccord rapide jusqu'à ce que l'épaulement soit parfaitement encastré dans le panneau. Il ne faut ni trop serrer ni insuffisamment serrer.

**ES\_QUICKFIT:** Apriete quickfit hasta que el hombro se descargue con el panel. NO lo sobreapriete ni lo apriete poco.

**DE\_QUICKFIT:** Ziehen Sie den Quickfit fest, bis die Schulter mit der Platte bündig ist. Bitte nicht zu fest oder zu schwach anziehen.

**IT\_MONTAGGIO RAPIDO:** Stringere il montaggio rapido fino a quando la spalla è a filo con il pannello, non stringere troppo o troppo poco.

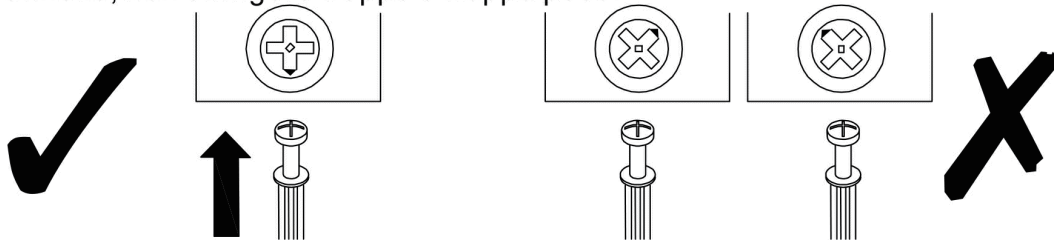

**EN\_CAM LOCK:** When fitting cam lock, ensure starting position is correct before you insert connecting quickfit.

**FR\_SERRURE BATTEUSE:** Avant d'insérer la serrure batteuse, veillez à la bonne orientation avant d'insérer le raccord rapide.

**ES\_CIERRE DE LA CÁMARA:** Cuando instale el cierre de la cámara, asegúrese de que la posición de inicio es correcta antes de que inserte el quickfit conector.

**DE\_CAM-LOCK:** Achten Sie bei der Montage des Cam-Locks auf die richtige Ausgangsposition, bevor Sie den Quickfit einsetzen.

**IT\_BLOCCAGGIO A CAMMA:** Quando si monta il bloccaggio a camma, assicurarsi che la posizione iniziale sia corretta prima di inserire il montaggio rapido di collegamento.

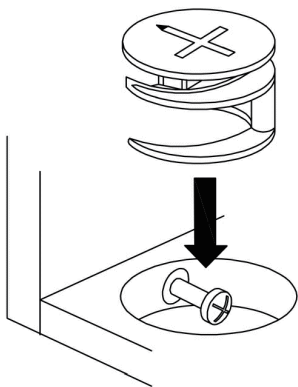

**EN\_Quickfit head should be in the centre of the cam lock when the two panels are joined.**

**Cam lock should be inserted before quickfit.**

**FR\_Lorsque les deux panneaux sont assemblés, la tête du raccord rapide doit reposer au centre de la serrure batteuse.**

**Il faut insérer la serrure batteuse avant le raccord rapide.**

**ES\_El cabezal del quickfit debe estar en el centro del cierre de la cámara cuando se unan los dos paneles.**

**Se debe insertar el cierre de la cámara antes que el quickfit.**

**DE\_Der Quickfit-Kopf sollte sich in der Mitte des Cam-Locks befinden, wenn die beiden Platten zusammengefügt sind.**

**Der Cam-Lock sollte vor dem Quickfit eingesetzt werden.**

**IT\_La testa del montaggio rapido deve trovarsi al centro del bloccaggio a camma quando i due pannelli sono uniti.**

**Il Bloccaggio a Camma deve essere inserito prima del montaggio rapido.**

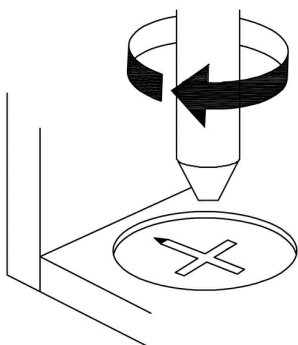

**EN\_Turn cam lock clockwise to tighten.**

**FR\_Faites tourner la serrure batteuse dans le sens des aiguilles d'une montre pour la resserrer.**

**ES\_Gire el cierre de la cámara en sentido horario para apretarlo.**

**DE\_Drehen Sie den Cam-Lock im Uhrzeigersinn, um ihn festzuziehen.**

**IT\_Ruotare il bloccaggio a camma in senso orario per stringere.**

## DE

1. Die maximale Tragfähigkeit der Oberplatte beträgt 60 kg, bitte nicht überladen.
2. Lassen Sie Kinder nicht auf Möbeln klettern, da dies zu Umstürzen und schweren Verletzungen führen kann.
3. Um die Sicherheit zu gewährleisten, installieren Sie bitte gemäß der Anleitung und ziehen Sie bei Bedarf Fachleute hinzu.
4. Stellen Sie Möbel nicht in die Nähe von Feuerquellen oder heißen Gegenständen, um Brandgefahr zu vermeiden.
5. Stellen Sie Möbel nicht in feuchten Umgebungen auf, um Materialschäden zu verhindern.
6. Überprüfen Sie regelmäßig alle Verbindungs- und Befestigungselemente, um sicherzustellen, dass sie fest sitzen und Unfälle zu vermeiden.

## UK

1. The maximum weight capacity of the top panel is 60kg; please do not overload.
2. Do not allow children to climb on furniture, as this may cause tipping and serious injury.
3. To ensure safety, please install correctly according to the instructions and seek professional assistance if necessary.
4. Do not place furniture near fire sources or hot objects to avoid fire hazards.
5. Do not place furniture in damp environments to prevent material damage.
6. Regularly check all connectors and fasteners to ensure they are secure to prevent accidents.

## FR

1. La charge maximale du panneau supérieur est de 60 kg, ne pas surcharger.
2. Ne laissez pas les enfants grimper sur les meubles, cela peut entraîner des basculements et des blessures graves.
3. Pour garantir la sécurité, installez correctement selon les instructions et demandez l'aide de professionnels si nécessaire.
4. Ne placez pas les meubles près de sources de chaleur ou d'objets chauds pour éviter les risques d'incendie.
5. Ne placez pas les meubles dans des environnements humides pour éviter d'endommager les matériaux.
6. Vérifiez régulièrement tous les connecteurs et les fixations pour vous assurer qu'ils sont bien serrés et éviter les accidents.

## IT

1. La capacità massima del pannello superiore è di 60 kg; non sovraccaricare.
2. Non permettere ai bambini di arrampicarsi sui mobili, poiché ciò può causare ribaltamenti e gravi infortuni.
3. Per garantire la sicurezza, installare correttamente secondo le istruzioni e, se necessario, chiedere assistenza a professionisti.
4. Non posizionare i mobili vicino a fonti di calore o oggetti caldi per evitare rischi di incendio.
5. Non posizionare i mobili in ambienti umidi per prevenire danni ai materiali.
6. Controllare regolarmente tutti i connettori e le viti per assicurarsi che siano saldi e prevenire incidenti.

## ES

1. La capacidad máxima del panel superior es de 60 kg; no sobrecargar.
2. No permita que los niños escalen los muebles, ya que esto puede causar volcaduras y lesiones graves.
3. Para garantizar la seguridad, instale correctamente según las instrucciones y busque ayuda profesional si es necesario.
4. No coloque los muebles cerca de fuentes de fuego u objetos calientes para evitar riesgos de incendio.
5. No coloque los muebles en ambientes húmedos para evitar daños en los materiales.
6. Revise regularmente todos los conectores y sujetadores para asegurarse de que estén seguros y prevenir accidentes.

## NL

1. De maximale draagcapaciteit van het bovenpaneel is 60 kg; niet overbelasten.
2. Laat kinderen niet op meubels klimmen, dit kan leiden tot omvallen en ernstige verwondingen.
3. Installeer correct volgens de instructies om de veiligheid te waarborgen, en schakel indien nodig professionele hulp in.
4. Plaats meubels niet in de buurt van vuurbronnen of warme objecten om brandgevaar te voorkomen.
5. Plaats meubels niet in vochtige omgevingen om materiaalschade te voorkomen.
6. Controleer regelmatig alle verbindingen en bevestigingsmiddelen om ervoor te zorgen dat ze stevig zijn en om ongevallen te voorkomen.

## SE

1. Den maximala viktkapaciteten för överpanelen är 60 kg; överbelasta inte.
2. Låt inte barn klättra på möbler, då detta kan orsaka tippning och allvarliga skador.
3. För att säkerställa säkerheten, installera korrekt enligt instruktionerna och sök professionell hjälp om det behövs.
4. Placera inte möbler nära eldkällor eller heta föremål för att undvika brandrisk.
5. Placera inte möbler i fuktiga miljöer för att förhindra skador på materialen.
6. Kontrollera regelbundet alla kopplingar och fästelement för att säkerställa att de är säkra för att förhindra olyckor.

## PL

1. Maksymalne obciążenie górnej płyty wynosi 60 kg; nie przeciążaj.
2. Nie pozwól dzieciom wspinać się na meble, ponieważ może to prowadzić do przewrócenia się i poważnych obrażeń.
3. Aby zapewnić bezpieczeństwo, zainstaluj prawidłowo zgodnie z instrukcją i w razie potrzeby skorzystaj z pomocy profesjonalistów.
4. Nie stawiaj mebli w pobliżu źródeł ognia lub gorących przedmiotów, aby uniknąć ryzyka pożaru.
5. Nie stawiaj mebli w wilgotnych środowiskach, aby zapobiec uszkodzeniu materiałów.
6. Regularnie sprawdzaj wszystkie złącza i elementy mocujące, aby upewnić się, że są stabilne i aby zapobiec wypadkom.

## -Components - fittings

Please check you have all the panels listed below.

Note: The quantitie below are the correct amount to complete the assembly. In some cases more fittings may be supplied than are required.

## -Komponenten Verschraubungen

Bitte überprüfen Sie, ob Sie alle unten aufgeführten Panels haben.

Hinweis: Die folgende Menge ist die richtige Menge, um die Montage abzuschließen. In einigen Fällen können mehr Armaturen geliefert werden, als erforderlich.



## -Composants - accessoires

Veuillez vérifier que vous possédez tous les panneaux énumérés ci - dessous.

Remarque: les quantités ci - dessous sont les quantités correspondantes nécessaires pour terminer l'assemblage. Dans certains cas, plus d'accessoires que nécessaire peuvent être fournis.



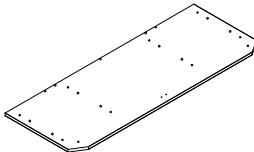
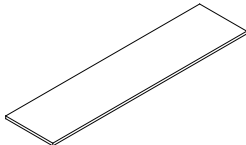
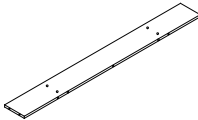
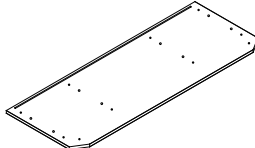
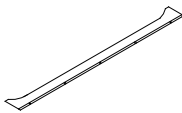
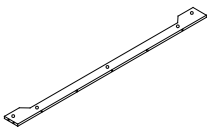

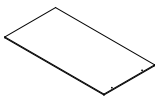
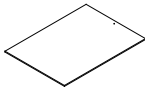
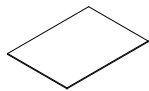

**N620P382328- Box:1/3**



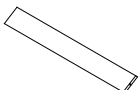

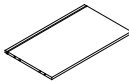

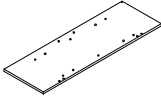
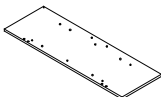
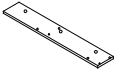
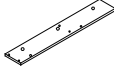

**N639P382386- Box:1/3**

 ①X1	 ②X1	 ⑬X1
 ⑲X1	 ⑳X1	 ㉑X1
 ㉓X6	 ㉔X2	 ㉕X1
 ㉖X1		

**N620P382329- Box:2/3**





**N639P382387- Box:2/3**

 ⑩X2	 ⑪X2	 ⑫X1
 ⑭X1	 ⑮X1	 ⑯X1

 $\textcircled{18} \times 2$	 $\textcircled{20} \times 1$	 $\textcircled{21} \times 1$
 $\textcircled{22} \times 2$	 $\textcircled{23} \times 2$	 $\textcircled{24} \times 4$
 $\textcircled{28} \times 1$	 $\textcircled{29} \times 1$	 $\textcircled{30} \times 2$
 $\textcircled{33} \times 6$	 $\textcircled{34} \times 6$	 $\textcircled{35} \times 6$
 $\textcircled{36} \times 6$		

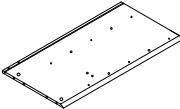
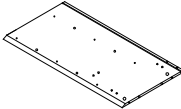
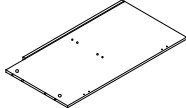
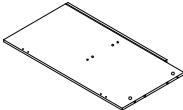
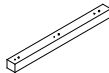
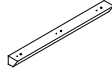
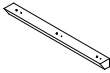
**N620P382330- Box:2/3**

**N639P382388- Box:2/3**

 $\textcircled{3} \times 1$	 $\textcircled{4} \times 1$	 $\textcircled{5} \times 1$
 $\textcircled{6} \times 1$	 $\textcircled{7} \times 2$	 $\textcircled{8} \times 1$
 $\textcircled{9} \times 1$	 $\textcircled{17} \times 3$	 $\textcircled{19} \times 1$
 $\textcircled{25} \times 4$	 $\textcircled{32} \times 5$	

## •Components - fittings

Please check you have all the panels listed below.

Note: The quantitie below are the correct amount to complete the assembly. In some cases more fittings may be supplied than are required.

## •Komponenten Verschraubungen

Bitte überprüfen Sie, ob Sie alle unten aufgeführten Panels haben.

Hinweis: Die folgende Menge ist die richtige Menge, um die Montage abzuschließen. In einigen Fällen

können mehr Armaturen geliefert werden, als erforderlich.

## •Composants - accessoires











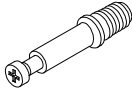

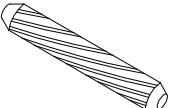

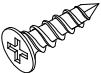
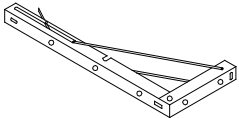
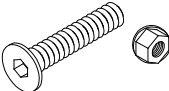
Veillez vérifier que vous possédez tous les panneaux énumérés ci - dessous.

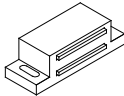
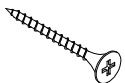
Remarque: les quantités ci - dessous sont les quantités correspondantes nécessaires pour terminer

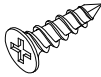
l'assemblage. Dans certains cas, plus d'accessoires que nécessaire peuvent être fournis.

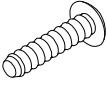
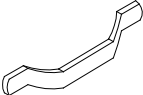
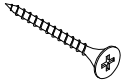
**N620P382330- Box3**

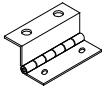
**N639P382388- Box:3**

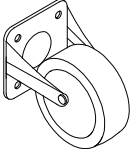
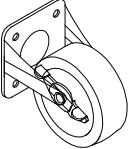
				
6*35mm	15*10mm	6*30mm	300mm	3*10mm
Ax93PCS	Bx93PCS	Cx62PCS	Dx6PCS	Ex72PCS
				
Fx2PCS	6*25mm	Hx1PC	Ix1PC	4*35mm
Gx4PCS	Jx46PCS			
				
Kx3PCS	3*14mm	Mx12PCS	4*14mm	4*14mm
Lx14PCS	Nx26PCS	Ox16PCS		
				
Px8PCS	4*30mm	2.5*10mm	Sx4PCS	Tx2PCS
Qx24PCS	Rx6PCS			
				
Ux3PCS	Vx2PCS			

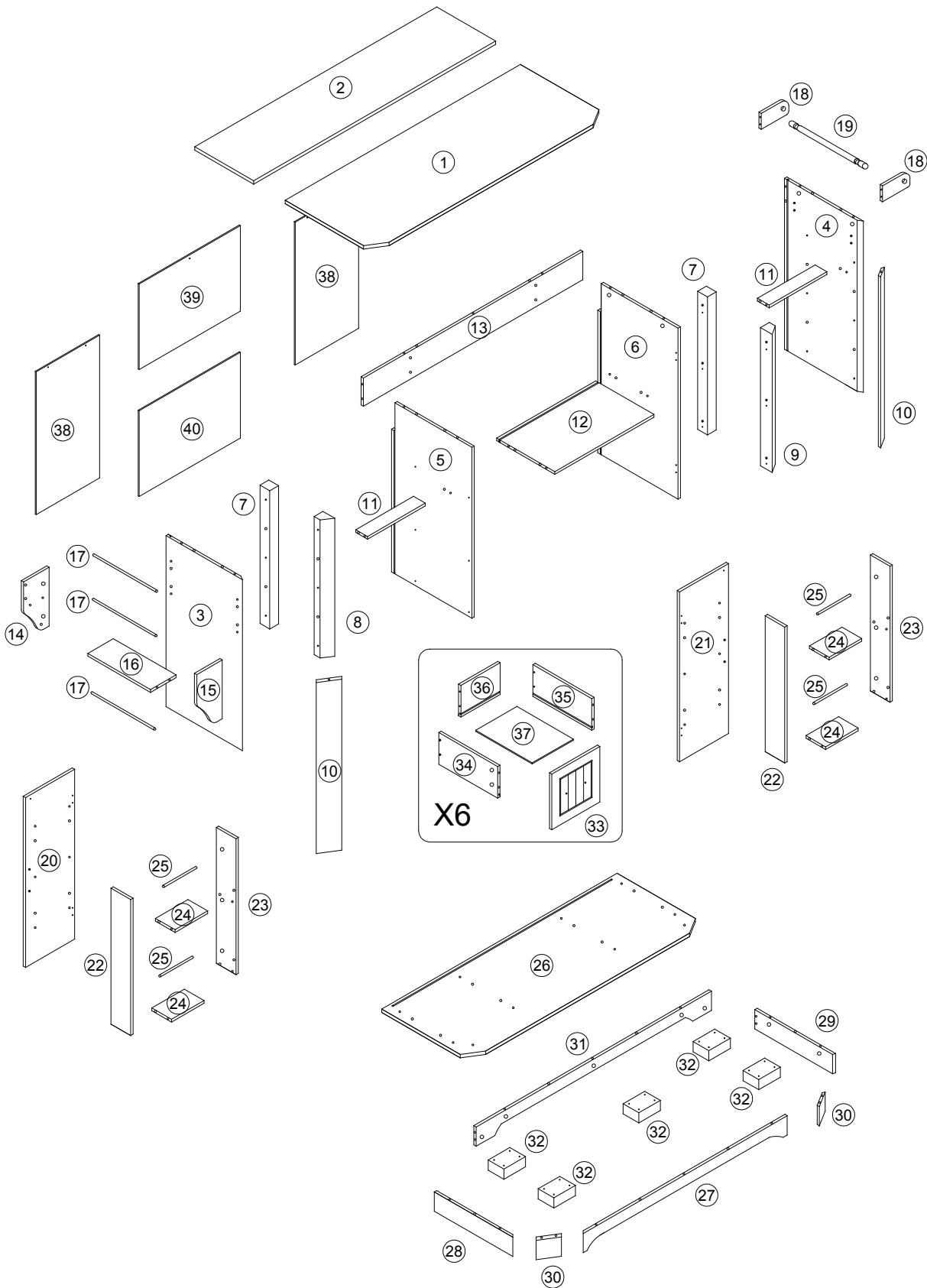



Importeur	Decobus Handel GmbH		
Adresse	Innungsstraße 9, 21244 Buchholz, Deutschland		
URL	<a href="https://www.decobusgroup.de">https://www.decobusgroup.de</a>		
Hersteller	Ningde Yibang Furniture Co., Ltd		
Adresse	No. 1, Industrial Zone, Gantang Village, Gantang Township, Pingnan County, Ningde City, Fujian, China.		
Email/URL	yvonne@yibang-fur.com		
Partienummer	N620P382328/N620P382329/N620P382330		
Hergestellt in	CHINA		
<table border="1" style="display: inline-table;"> <tr> <td>EC</td> <td>REP</td> </tr> </table>	EC	REP	Decobus Handel GmbH Innungsstraße 9, 21244 Buchholz, Deutschland <a href="https://www.decobusgroup.de">https://www.decobusgroup.de</a>
EC	REP		

Importer	COMHARBOR LIMITED		
Add	Unit C, Swift Point, Cosford Lane, Rugby, CV21 1PY, GB		
Email/URL	harborcomhar@gmail.com		
Manufacturer	Ningde Yibang Furniture Co., Ltd		
Add	No. 1, Industrial Zone, Gantang Village, Gantang Township, Pingnan County, Ningde City, Fujian, China.		
Email/URL	yvonne@yibang-fur.com		
Product identification	N639P382386/N639P382387/N639P382388		
Made in	CHINA		
<table border="1" style="display: inline-table;"> <tr> <td>UK</td> <td>REP</td> </tr> </table>	UK	REP	COMHARBOR LIMITED Unit C, Swift Point, Cosford Lane, Rugby, CV21 1PY, GB harborcomhar@gmail.com
UK	REP		

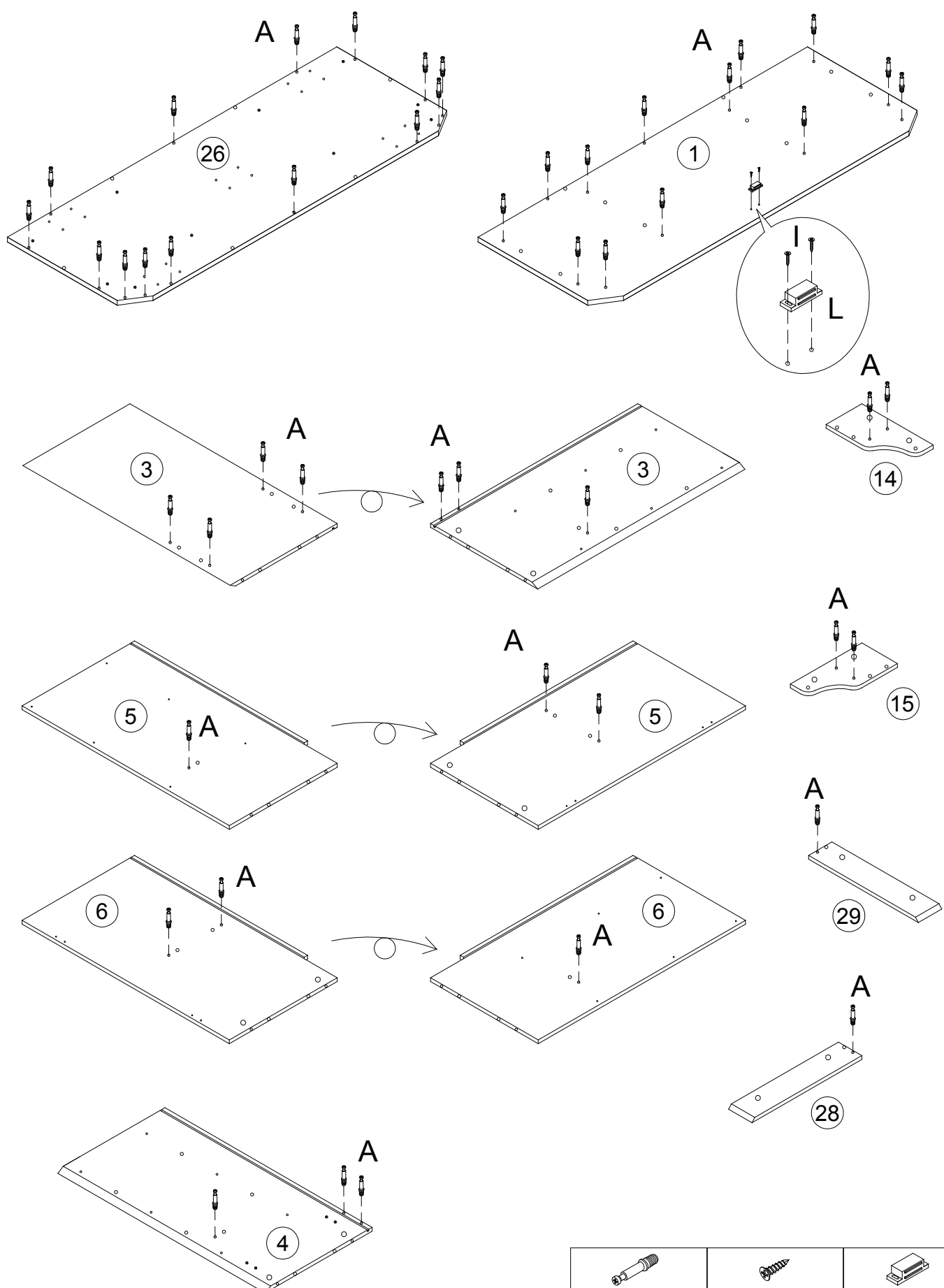

STEP 1/SCHRITT 1/étapes 1/Passo 1/Paso 1



		
A x 49pcs	L x 2pcs	I x 1pc

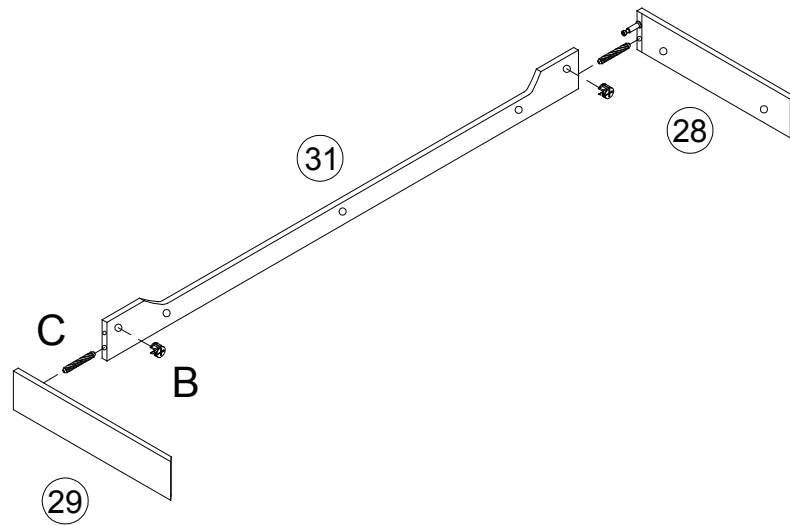

## STEP 2/SCHRITT 2/étapes 2/Passo 2/Paso 2



	
B x 2pcs	C x 2pcs

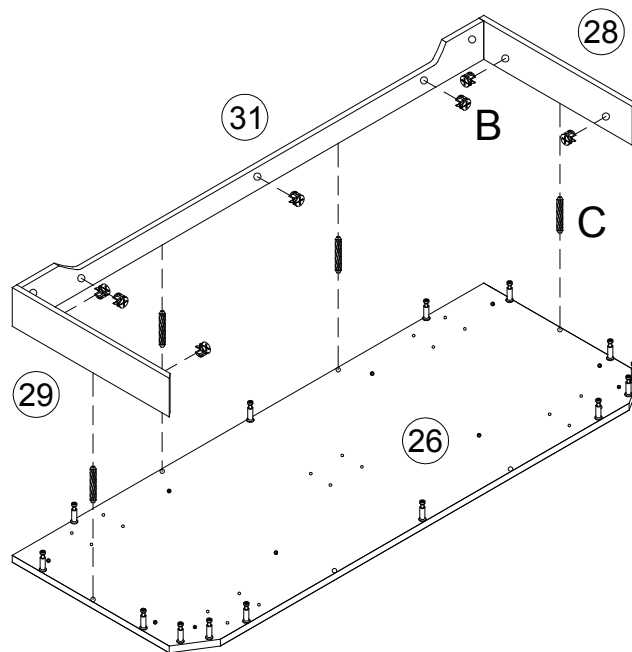

## STEP 3/SCHRITT 3/étapes 3/Passo 3/Paso 3

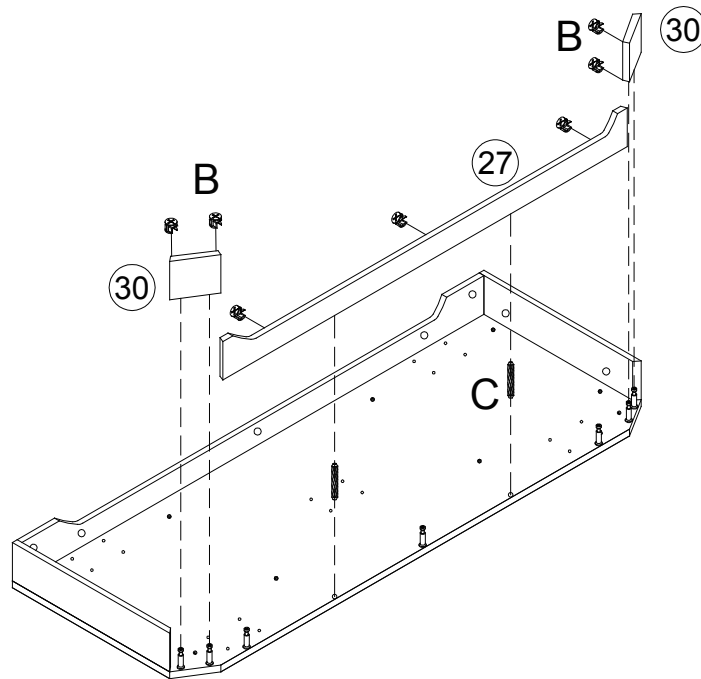

	
B x 7pcs	C x 4pcs

### STEP 4/SCHRITT 4/étapes 4/Passo 4/Paso 4



	
B x 7pcs	C x 2pcs

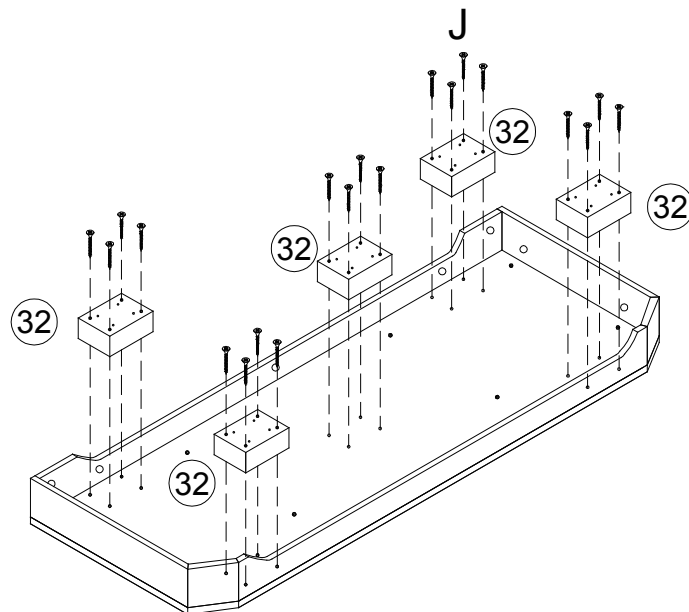

### STEP 5/SCHRITT 5/étapes 5/Passo 5/Paso 5



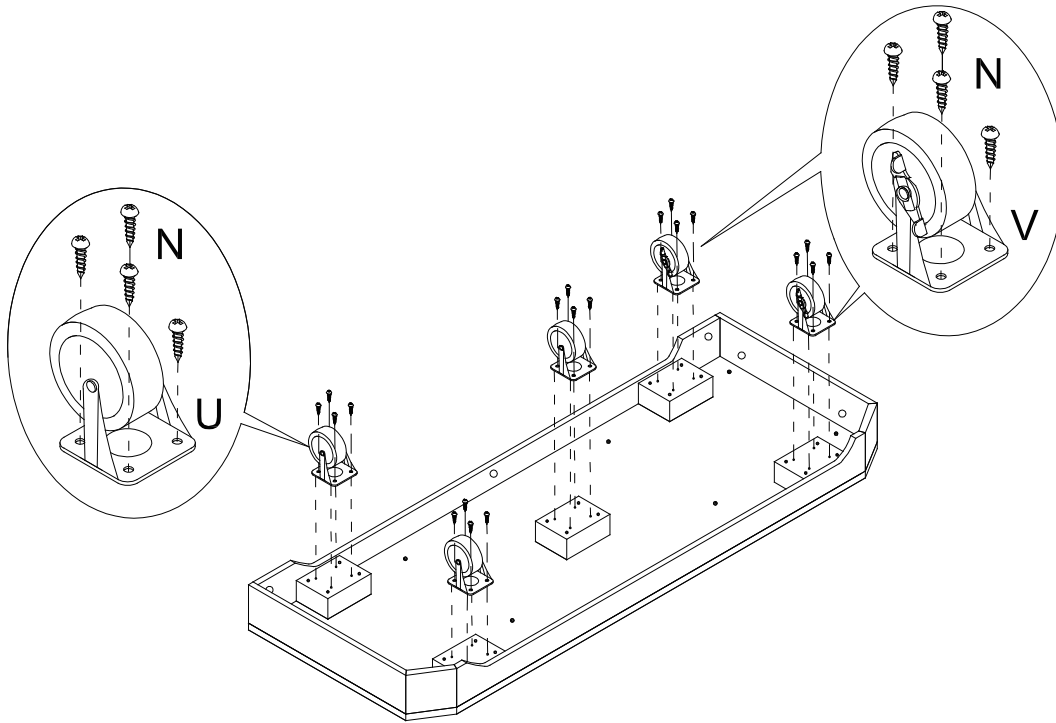

J x 20pcs



### STEP 6/SCHRITT 6/étapes 6/Passo 6/Paso 6

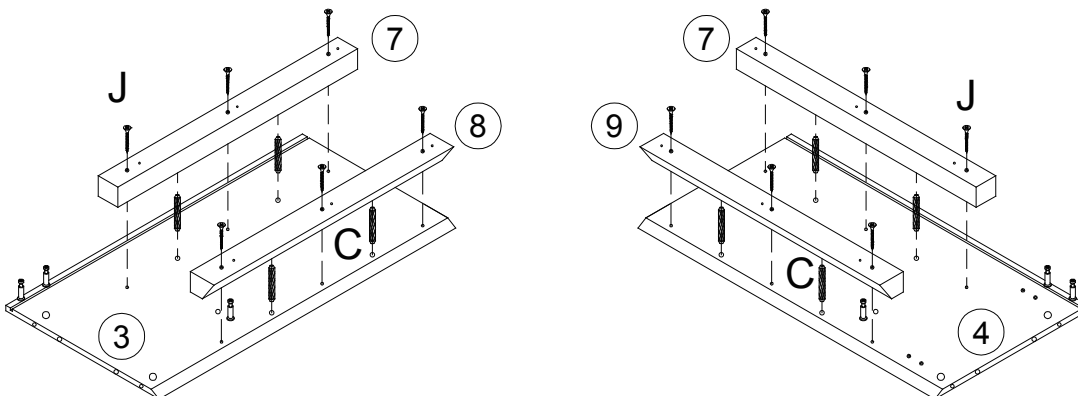

		
N x 20pcs	U x 3pcs	V x 2pcs

### STEP 7/SCHRITT 7/étapes 7/Passo 7/Paso 7



	
C x 8pcs	J x 12pcs

# STEP 8/SCHRITT 8/étapes 8/Passo 8/Paso 8

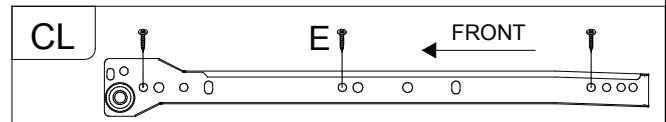
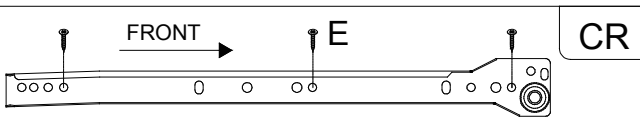
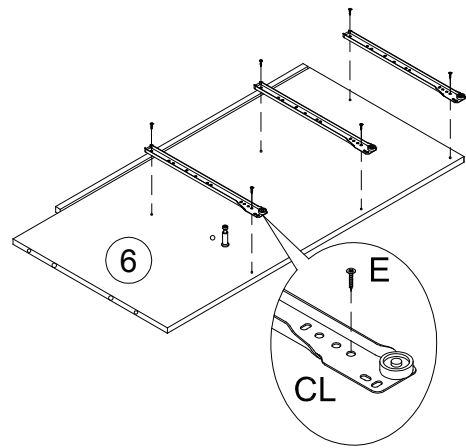
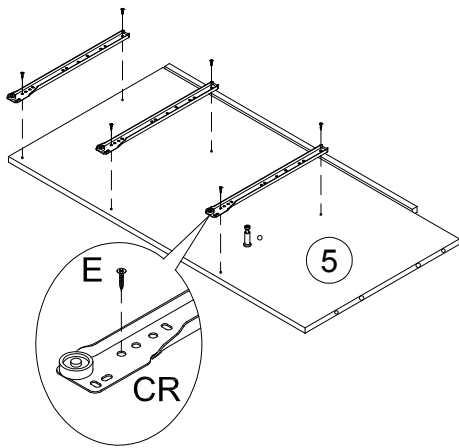
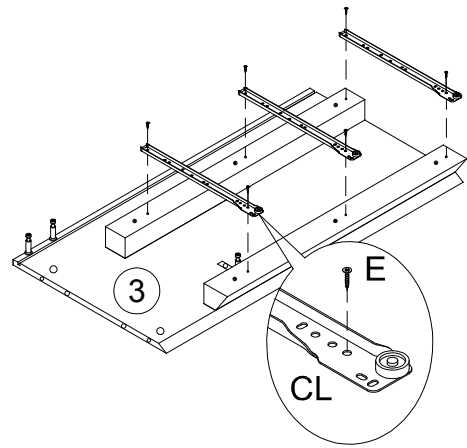
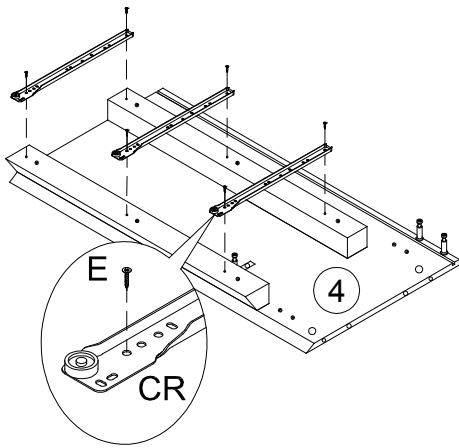
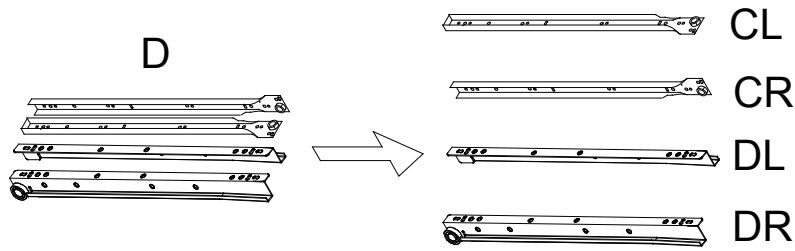

E x 24pcs	CL x 6pcs	CR x 6pcs

**STEP 9/SCHRITT 9/  
 étapes 9/Passo 9/Paso 9**

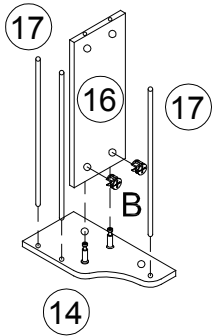



B x 2pcs

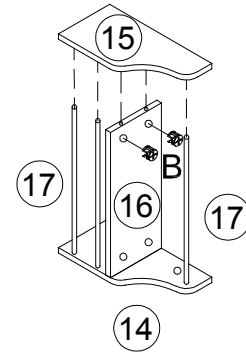

**STEP 10/SCHRITT 10/  
 étapes 10/Passo 10/Paso 10**



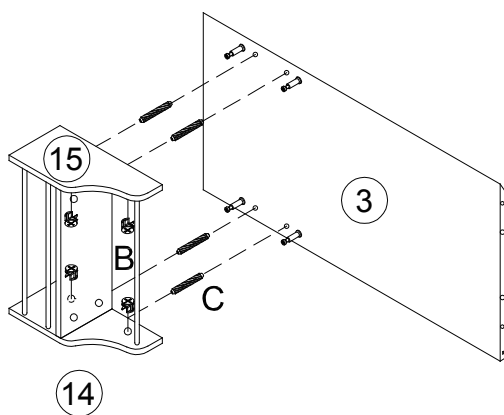

B x 2pcs

**STEP 11/SCHRITT 11/  
 étapes 11/Passo 11/Paso 11**



	
B x 4pcs	C x 4pcs

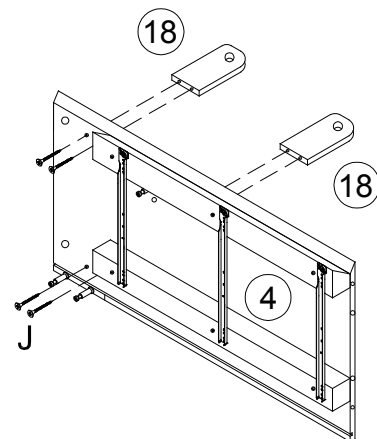

**STEP 12/SCHRITT 12/  
 étapes 12/Passo 12/Paso 12**



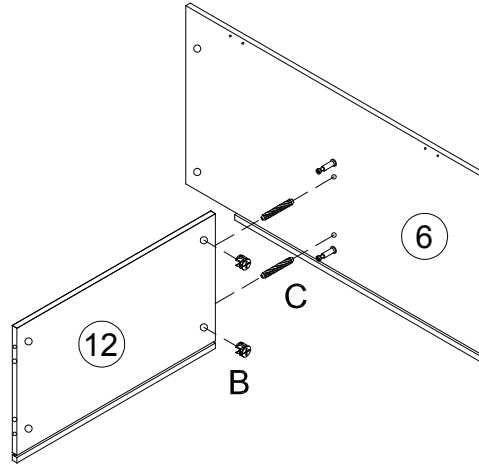

J x 4pcs



## STEP 13/SCHRITT 13/étapes 13/Passo 13/Paso 13

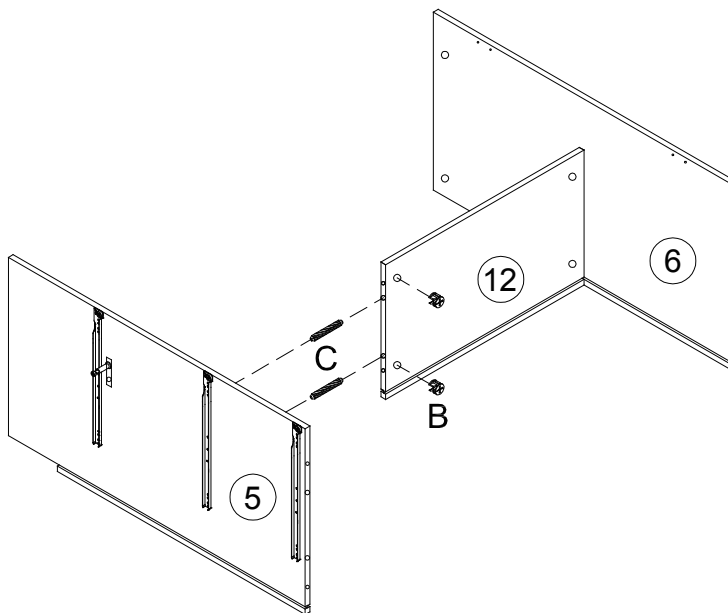

	
B x 2pcs	C x 2pcs



## STEP 14/SCHRITT 14/étapes 14/Passo 14/Paso 14

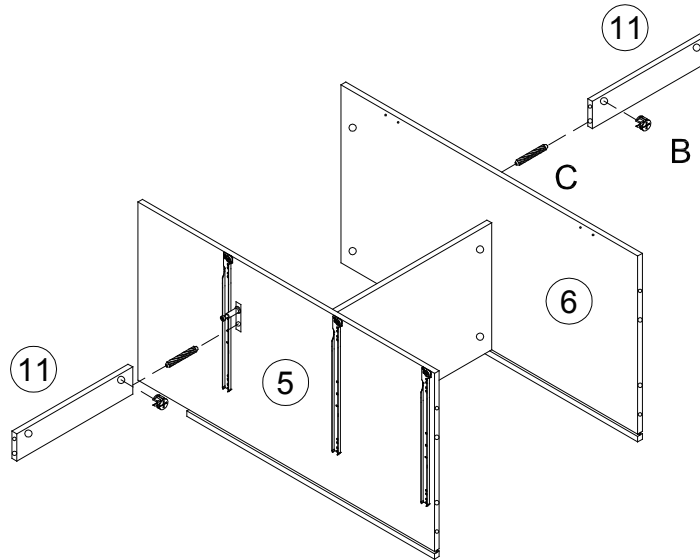

	
B x 2pcs	C x 2pcs

## STEP 15/SCHRITT 15/étapes 15/Passo 15/Paso 15



	
B x 2pcs	C x 2pcs

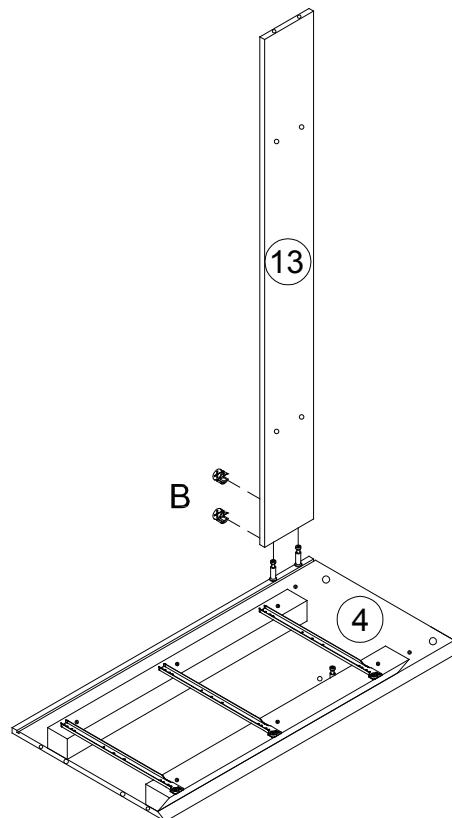

## STEP 16/SCHRITT 16/étapes 16/Passo 16/Paso 16



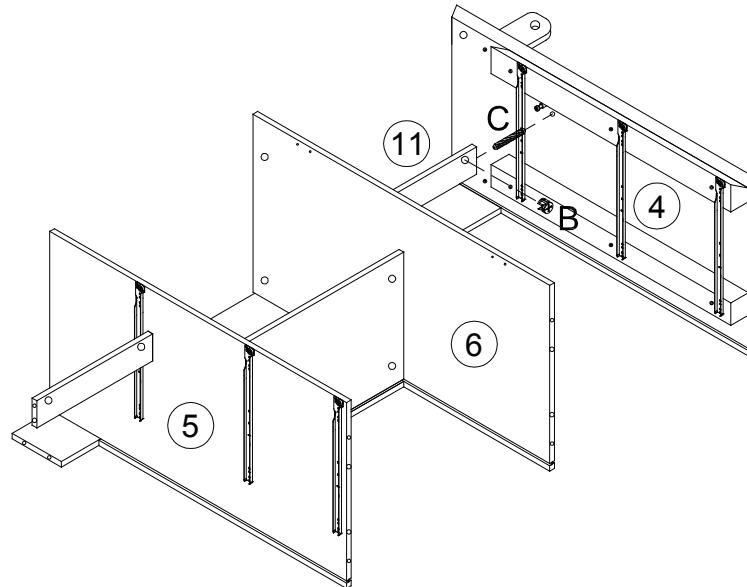

B x 2pcs



## STEP 17/SCHRITT 17/étapes 17/Passo 17/Paso 17

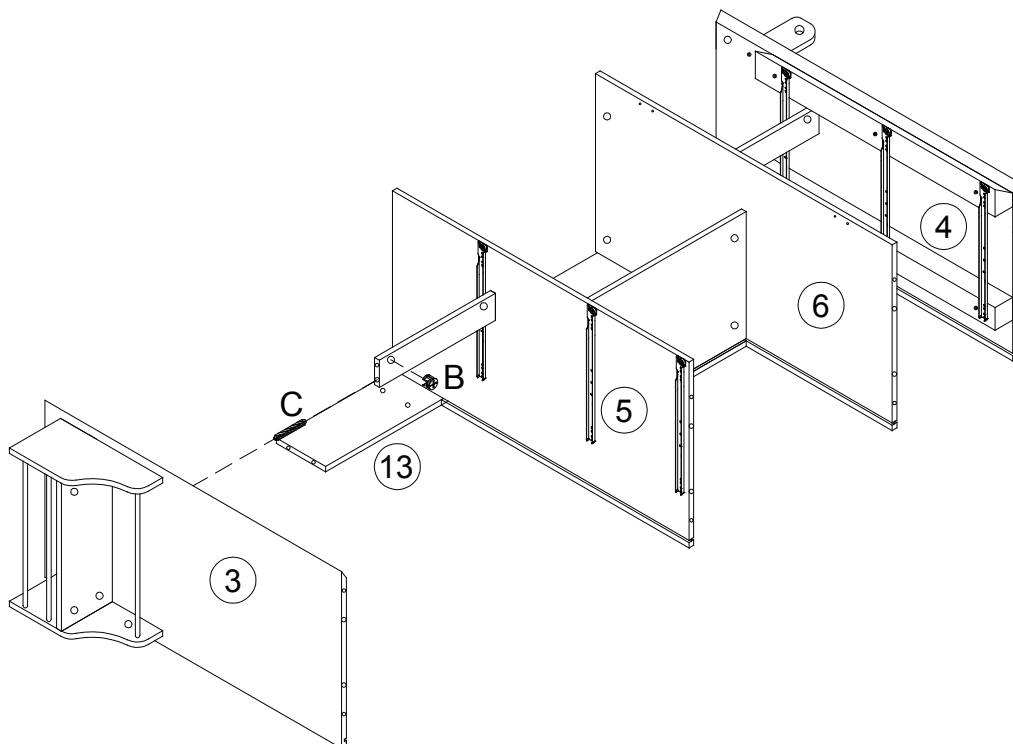

	
B x 1pc	C x 1pc

## STEP 18/SCHRITT 18/étapes 18/Passo 18/Paso 18



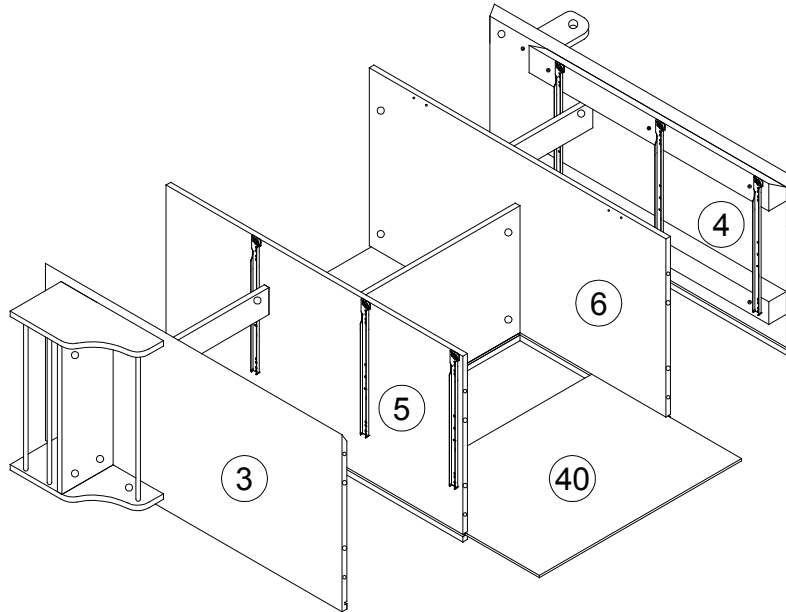

	
B x 1pc	C x 1pc

## STEP 19/SCHRITT 19/étapes 19/Passo 19/Paso 19

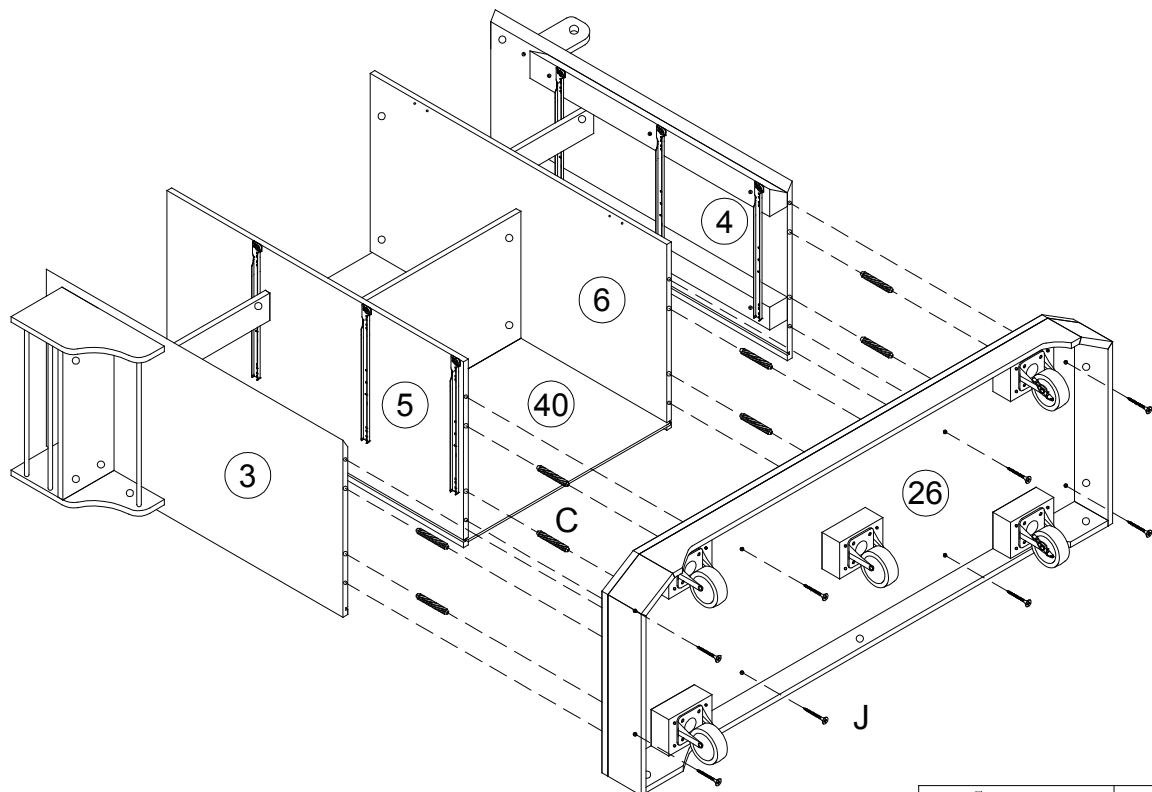

## STEP 20/SCHRITT 20/étapes 20/Passo 20/Paso 20



	
C x 8pcs	J x 8pcs

## STEP 28/SCHRITT 28/étapes 28/Passo 28/Paso 28

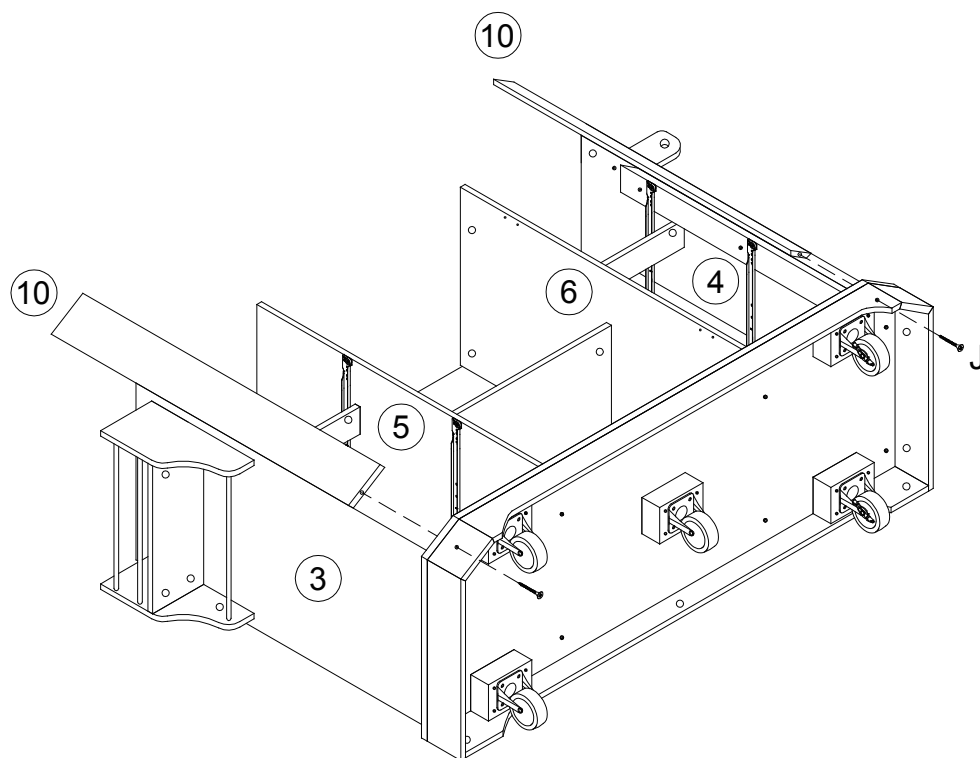



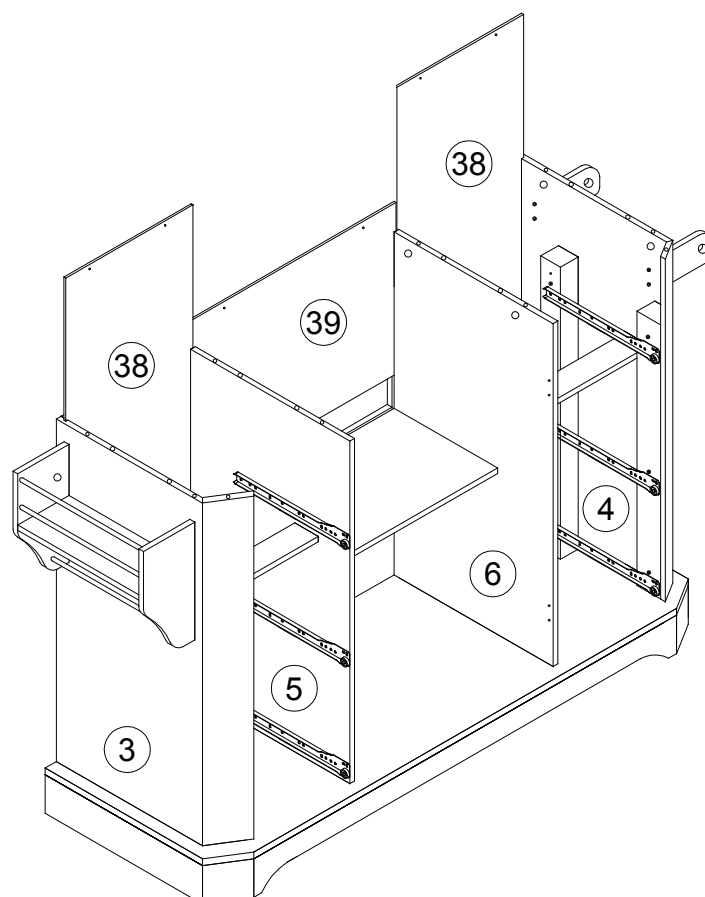

J x 2pcs

## STEP 29/SCHRITT 29/étapes 29/Passo 29/Paso 29

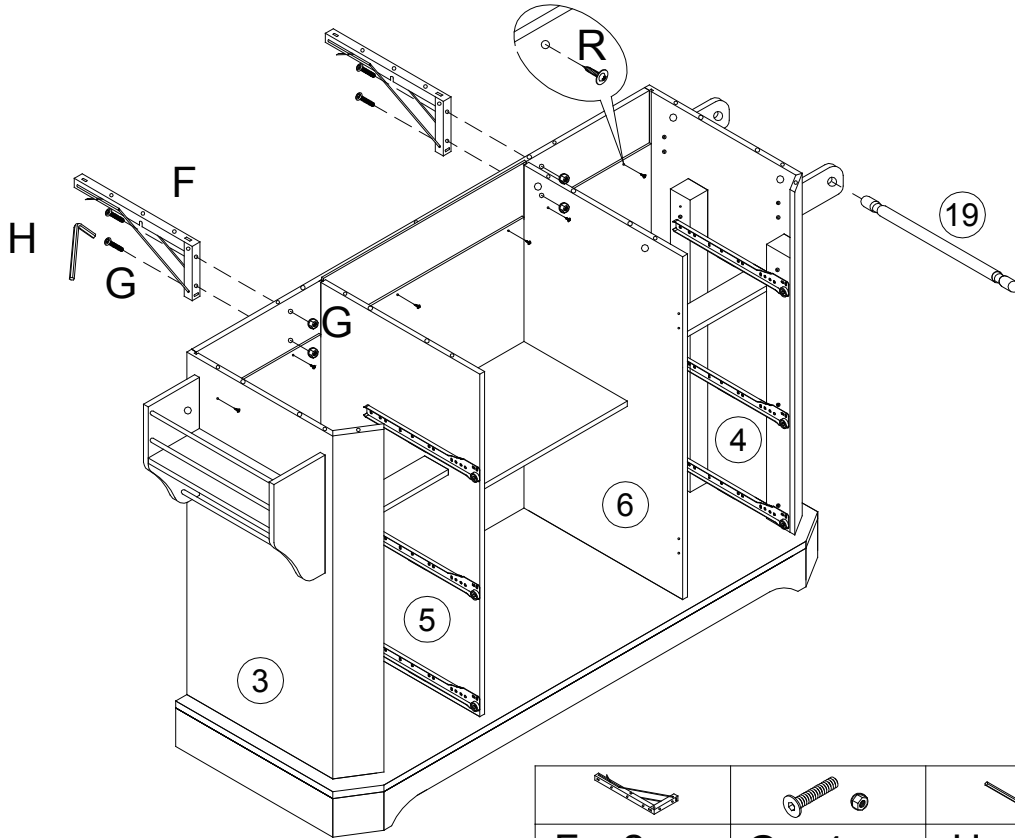



### STEP 30/SCHRITT 30/étapes 30/Passo 30/Paso 30



			
F x 2pcs	G x 4pcs	H x 1pc	R x 6pcs

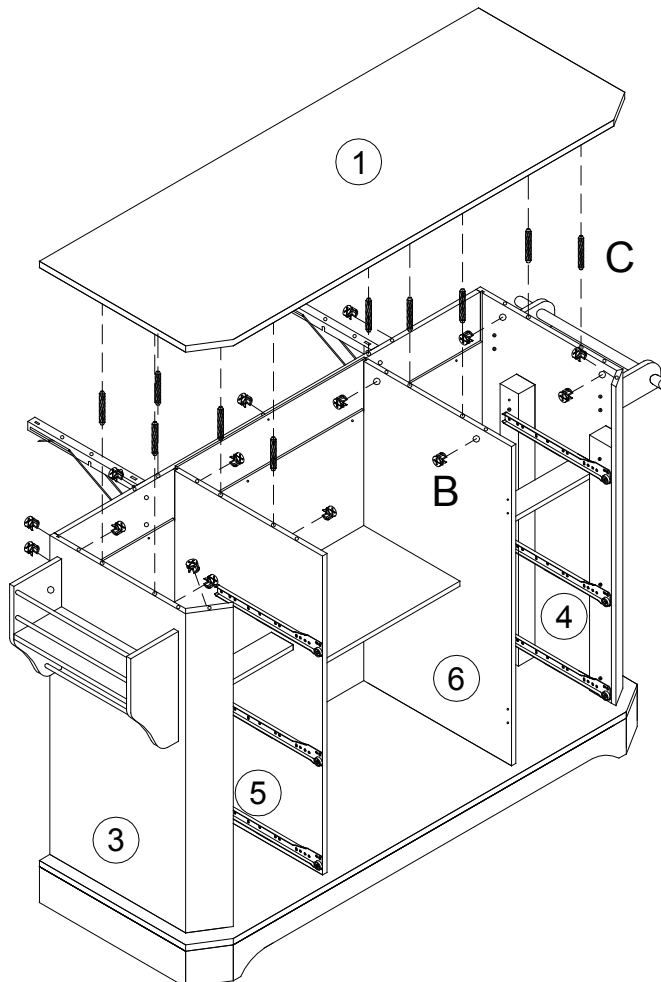



### STEP 31/SCHRITT 31/étapes 31/Passo 31/Paso 31

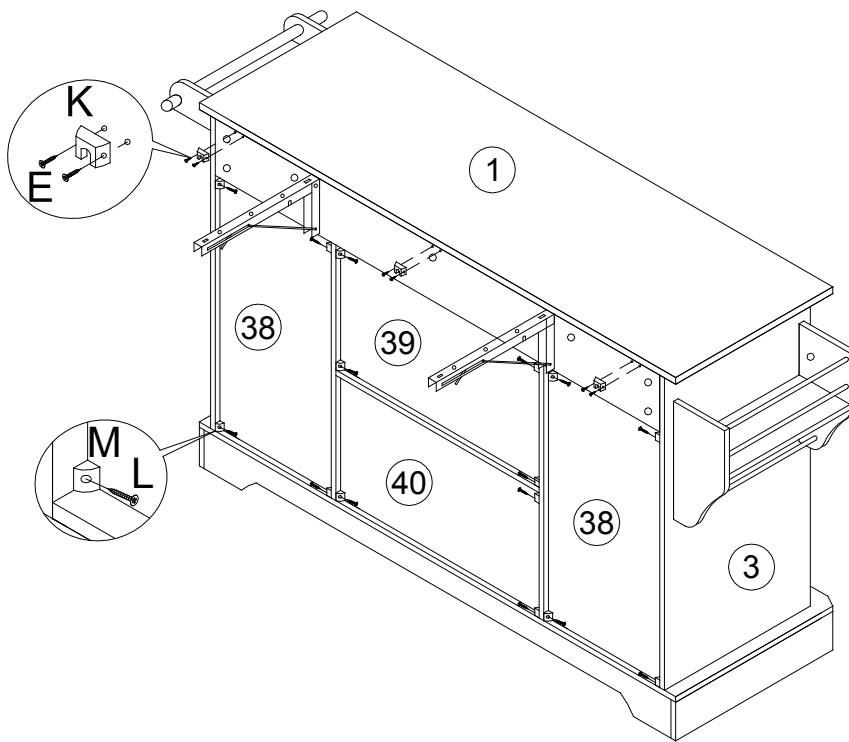

	
B x 15pcs	C x 10pcs

## STEP 32/SCHRITT 32/étapes 32/Passo 32/Paso 32



			
E x 6pcs	K x 3pcs	L x 12pcs	M x 12pcs



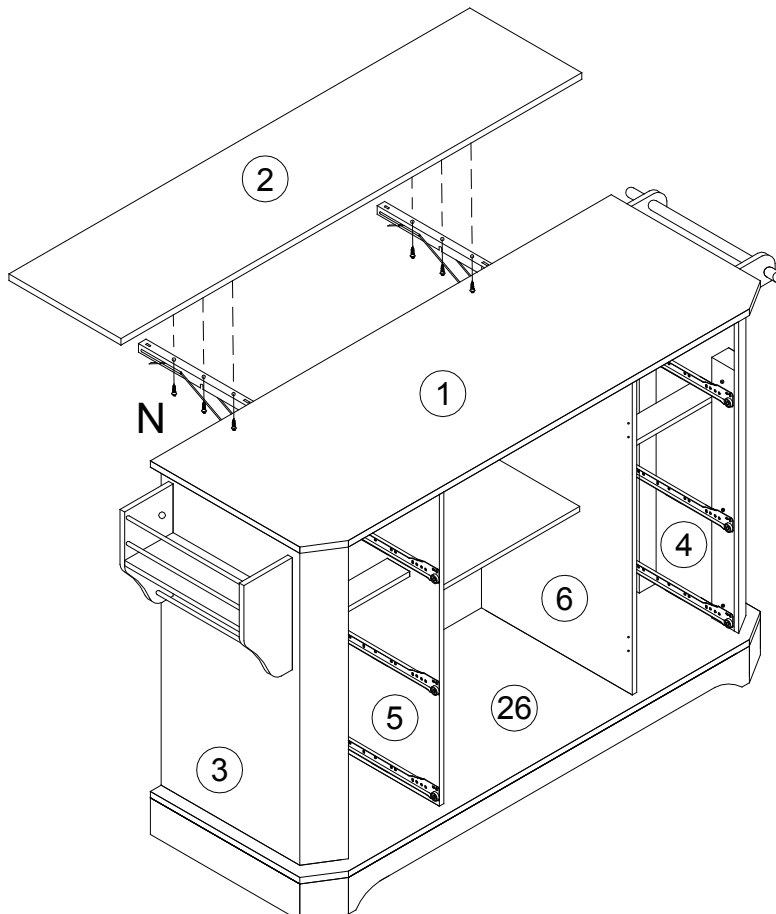

## STEP 33/SCHRITT 33/étapes 33/Passo 33/Paso 33



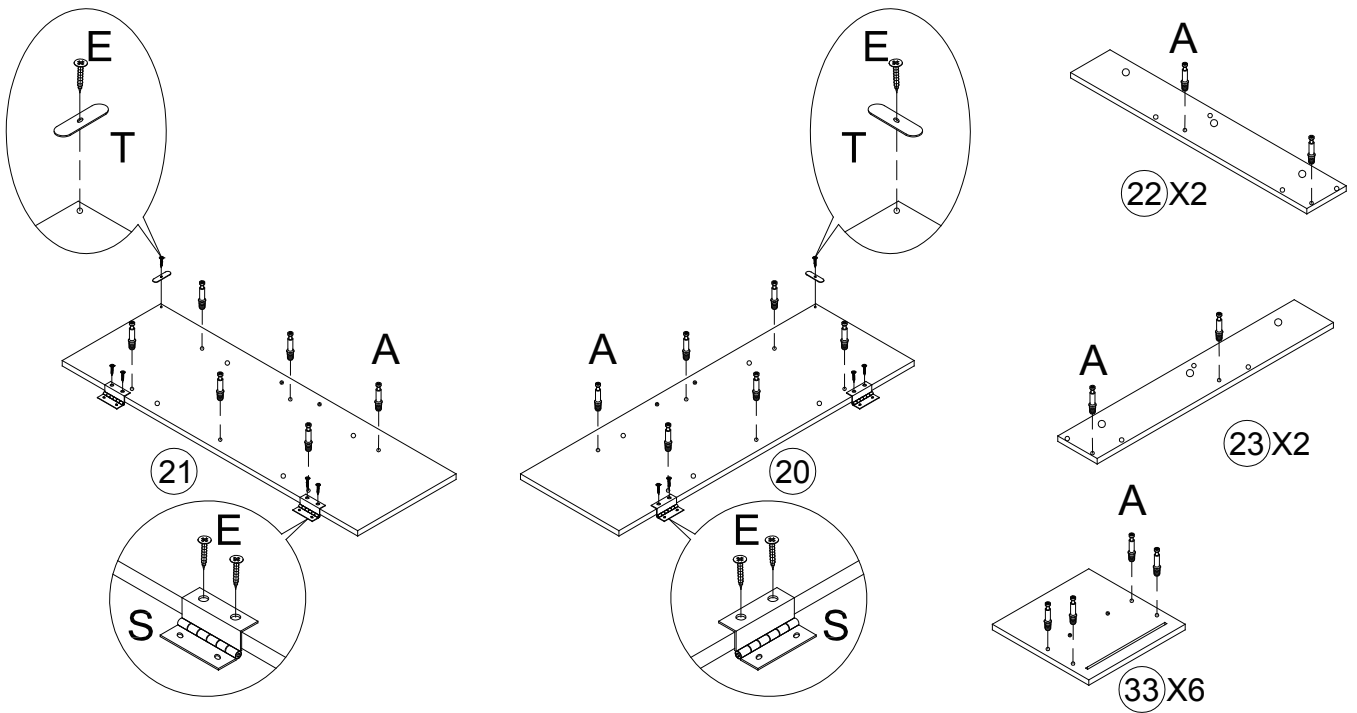

N x 6pcs



**STEP 34/SCHRITT 34/étapes 34/Passo 34/Paso 34**

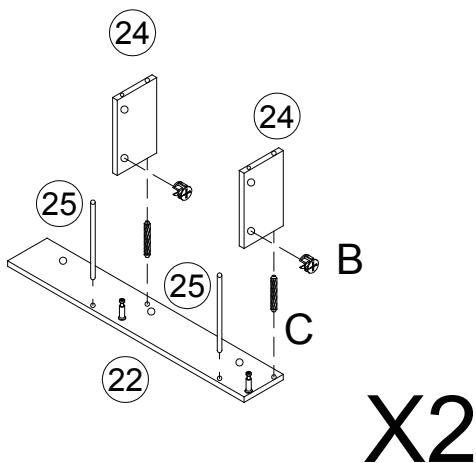

			
A x 44pcs	E x 10pcs	S x 4pcs	T x 2pcs



**STEP 35/SCHRITT 35/  
étapes 35/Passo 35/Paso 35**



	
B x 4pcs	C x 4pcs

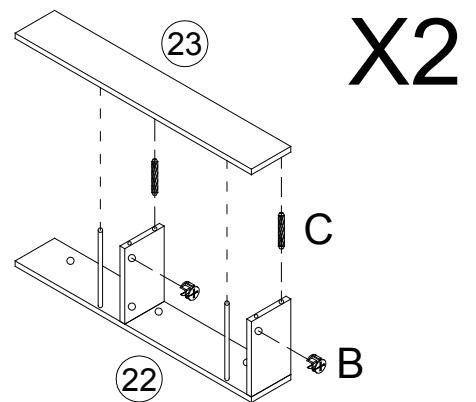

**STEP 36/SCHRITT 36/  
étapes 36/Passo 36/Paso 36**



	
B x 4pcs	C x 4pcs

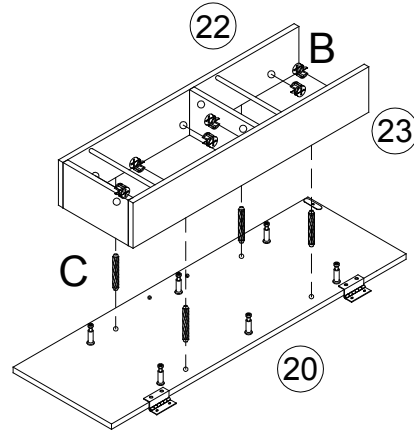
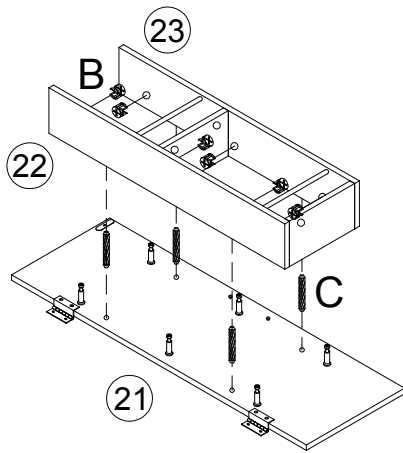

## STEP 37/SCHRITT 37/étapes 37/Passo 37/Paso 37

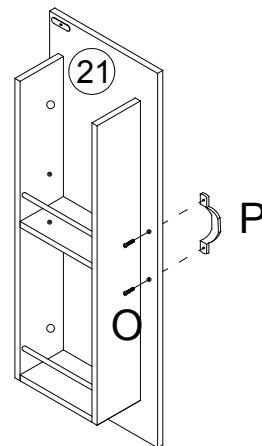
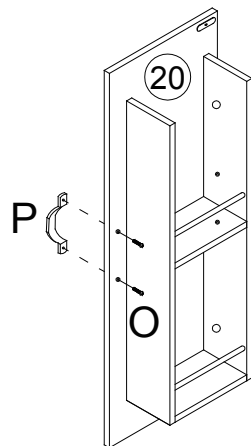

	
B x 12pcs	C x 8pcs

## STEP 38/SCHRITT 38/étapes 38/Passo 38/Paso 38



	
O x 4pcs	P x 2pcs

### STEP 39/SCHRITT 39/étapes 39/Passo 39/Paso 39

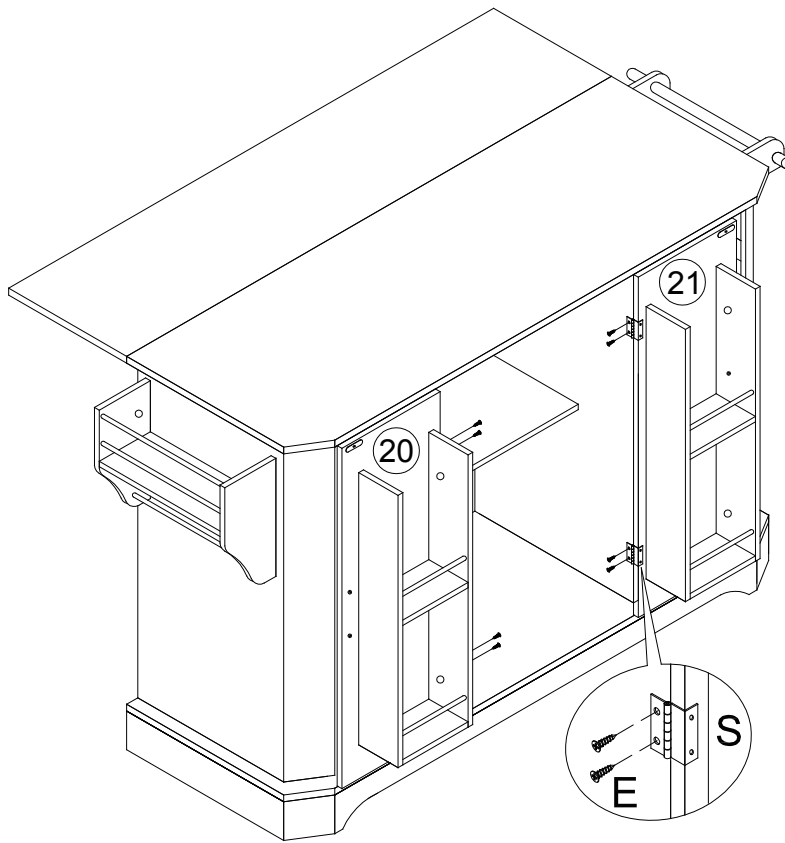

  
E x 8pcs

### STEP 40/SCHRITT 40/ étapes 40/Passo 40/Paso 40

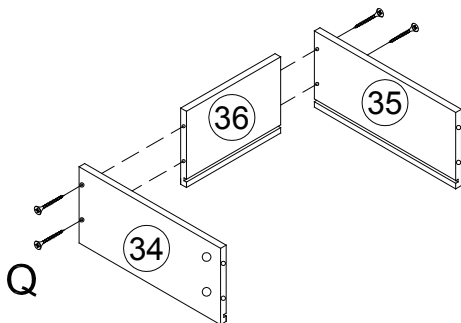

X6

  
Q x 24pcs

### STEP 41/SCHRITT 41/ étapes 41/Passo 41/Paso 41

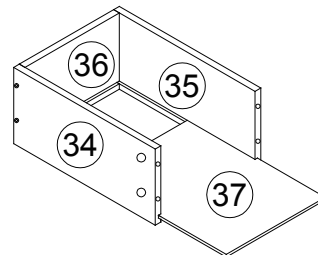

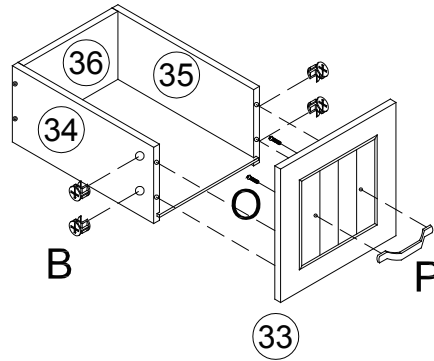

X6

STEP 42/SCHRITT 42/étapes 42/Passo 42/Paso 42



X6

		
B x 24pcs	O x 12pcs	P x 6pcs

STEP 43/SCHRITT 43/étapes 43/Passo 43/Paso 43

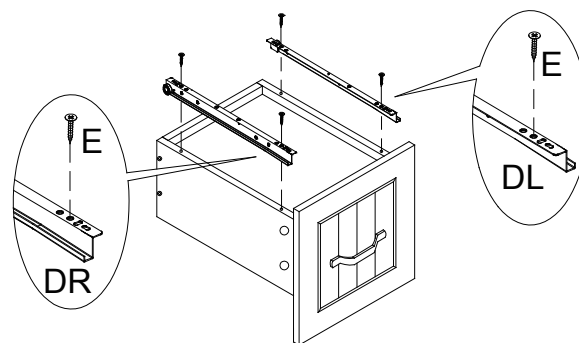
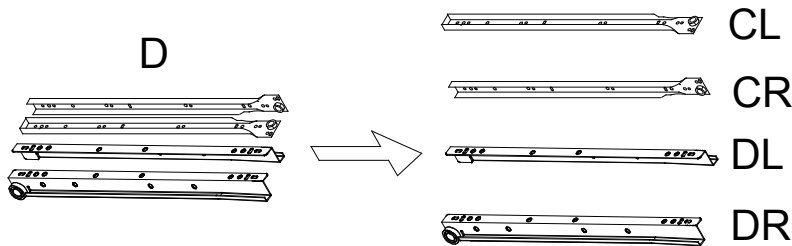

X6

		
E x 24pcs	DL x 6pcs	DR x 6pcs

