

# Montageanleitung | Instructions de montage Assembly Instructions | Instrucciones de montaje

SKU NUMBER: WF326333/WF326334

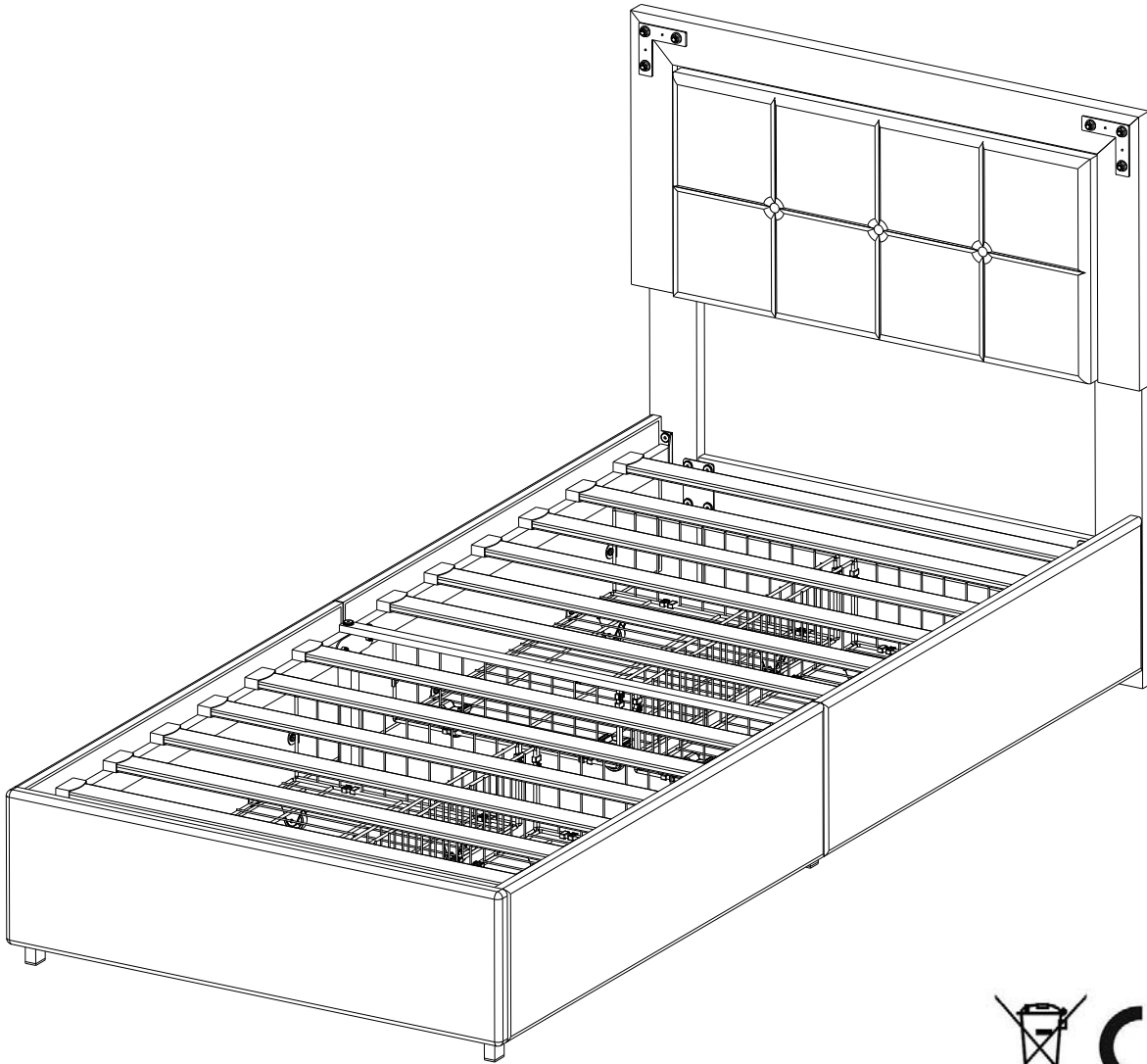

**GB** This set comes in 2 boxes. If you do not receive a full set of 2 boxes, please contact our customer service.

**DE** Dieses Set wird in 2 Schachteln geliefert. Wenn Sie nicht ein komplettes Set von 2 Boxen erhalten, kontaktieren Sie bitte unseren Kundenservice.

**FR** Ce set est livré en 2 boîtes. Si vous ne recevez pas un jeu complet de 2 boîtes, veuillez contacter notre service clientèle.

## English

### IMPORTANT ! KEEP FOR FUTURE REFERENCE : READ CAREFULLY

- To be assembled by an adult. Assembly must be checked by an adult before use
- WARNING ! Keep all screws, small parts and plastic bags out of the reach of children
- Properly identify all parts before assembling
- Never use your item if any of its parts are broken or missing
- Should any problems arise, please contact our After Sales Service
- Manufacturer's instructions shall be followed at all times
- Care: Clean with a soft, dry cloth. In case of larger stains, carefully rub with a slightly damp, non-abrasive sponge
- Avoid the risk of fire by not placing furniture near sources of ignition or hot items
- Do not jump on the bed

## Deutsch

### WICHTIG ! ZUM SPÄTEREN NACHSCHLAGEN AUFBEWAHREN: SORGFÄLTIG LESEN

- Muss von einem Erwachsenen zusammengebaut werden. Der Zusammenbau muss vor dem Gebrauch von einem Erwachsenen überprüft werden
- WARNUNG! Bewahren Sie alle Schrauben, Kleinteile und Plastikbeutel außerhalb der Reichweite von Kindern auf
- Kennzeichnen Sie vor dem Zusammenbau alle Teile richtig
- Benutzen Sie Ihren Artikel niemals, wenn Teile gebrochen sind oder fehlen
- Sollten Probleme auftreten, wenden Sie sich bitte an unseren Kundendienst
- Die Anweisungen des Herstellers sind stets zu befolgen
- Pflege: Mit einem weichen, trockenen Tuch reinigen. Bei größeren Flecken vorsichtig mit einem leicht feuchten, nicht scheuernden Schwamm abreiben. nicht scheuernden Schwamm
- Vermeiden Sie die Gefahr eines Brandes, indem Sie die Möbel nicht in der Nähe von Zündquellen oder heißen Gegenständen aufstellen
- Nicht auf das Bett springen

## Français

### IMPORTANT ! CONSERVER POUR RÉFÉRENCE ULTÉRIEURE : LIRE ATTENTIVEMENT

- Le montage doit être effectué par un adulte. Le montage doit être vérifié par un adulte avant Utilisation
- ATTENTION ! Tenir les vis, les petites pièces et les sachets en plastique hors de portée des enfants
- Identifiez correctement toutes les pièces avant de les assembler
- N'utilisez jamais votre article si l'une de ses pièces est cassée ou manquante
- En cas de problème, veuillez contacter notre service après-vente
- Les instructions du fabricant doivent être respectées à tout moment
- Entretien : nettoyer avec un chiffon doux et sec. En cas de taches plus importantes, frotter soigneusement avec une éponge non abrasive légèrement humide. légèrement humide et non Abrasive
- Évitez les risques d'incendie en ne plaçant pas les meubles à proximité de sources d'inflammation ou d'objets chauds
- Ne pas sauter sur le lit

**Italiano**

**IMPORTANTE! CONSERVARE PER RIFERIMENTO FUTURO: LEGGERE ATTENTAMENTE**

- Deve essere assemblato da un adulto. L'assemblaggio deve essere controllato da un adulto prima dell'uso
- **ATTENZIONE!** Tenere tutte le viti, le piccole parti e i sacchetti di plastica fuori dalla portata dei bambini
- Identificare correttamente tutte le parti prima dell'assemblaggio
- Non utilizzare mai l'articolo se alcune parti sono rotte o mancanti
- In caso di problemi, si prega di contattare il nostro Servizio Post Vendita
- Le istruzioni del produttore devono essere sempre seguite
- Cura: Pulire con un panno morbido e asciutto. In caso di macchie più estese, strofinare accuratamente con una spugna leggermente umida e nonspugna leggermente umida e non abrasiva
- Evitare il rischio di incendio, non collocando i mobili vicino a fonti di accensione o a oggetti caldi
- Non saltare sul letto

**Español**

**¡ IMPORTANTE ! CONSERVELO PARA FUTURAS CONSULTAS: LEA ATENTAMENTE**

- Debe ser montado por un adulto. El montaje debe ser comprobado por un adulto antes del uso
- ADVERTENCIA Mantenga todos los tornillos, piezas pequeñas y bolsas de plástico fuera del alcance de los niños.
- Identifique correctamente todas las piezas antes de montarlas
  - Nunca utilice su artículo si alguna de sus piezas está rota o falta
  - Si surge algún problema, póngase en contacto con nuestro Servicio Postventa
  - Las instrucciones del fabricante deben seguirse en todo momento
  - Cuidado: Limpiar con un paño suave y seco. En caso de manchas más grandes, frote cuidadosamente con una esponja no abrasiva ligeramente humedecida.
  - Evite el riesgo de incendio no colocando los muebles cerca de fuentes de ignición u objetos calientes.
  - No saltar sobre la cama.

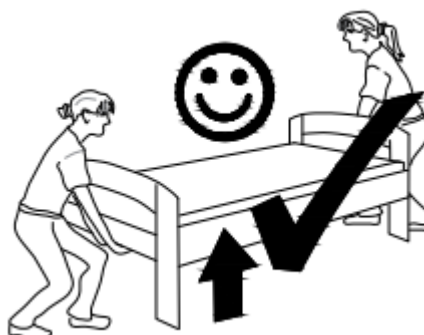
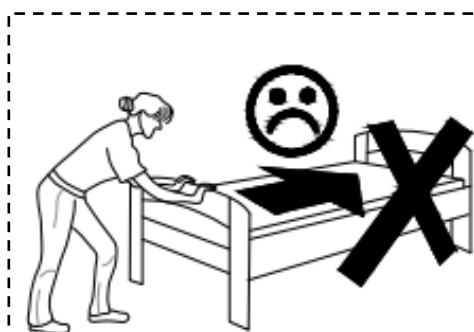

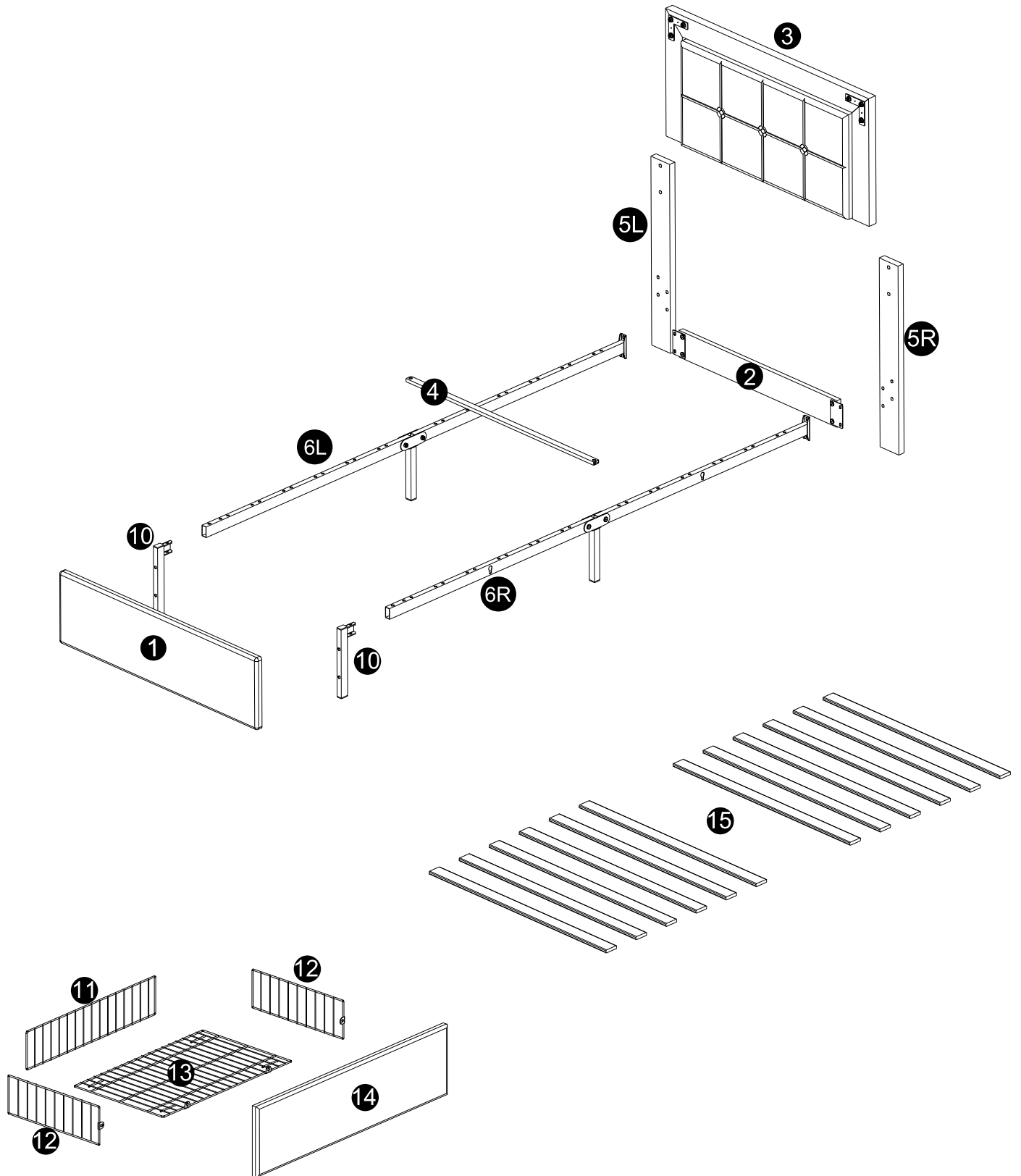

# Stückliste

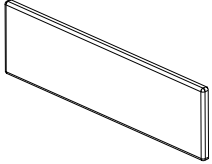
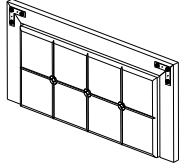
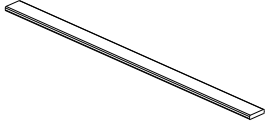
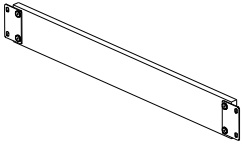
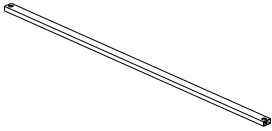

# WF326333



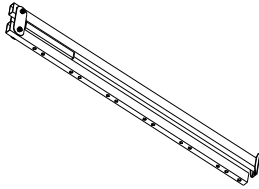
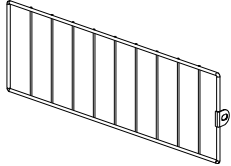

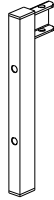
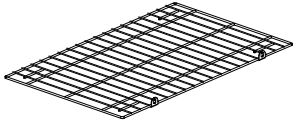
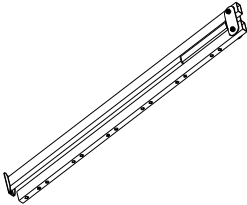
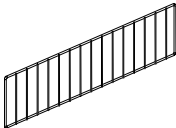
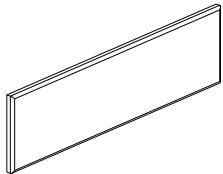
1		X1	3		X1	15		X12
2		X1	4		X1			

# WF326334

5L		X1	6R		X1	12		X8
5R		X1	10		X2	13		X4
6L		X1	11		X4	14		X4

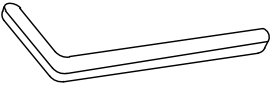
# Hardware List-Hardware-Liste-Liste du matériel

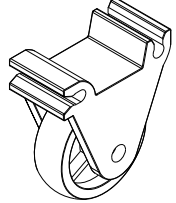
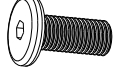
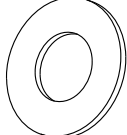
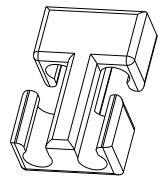
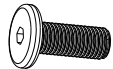
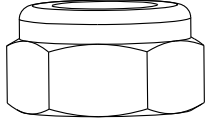
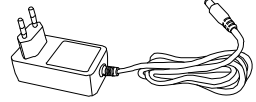
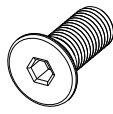
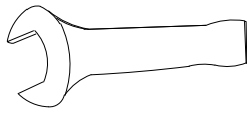
## WF326334

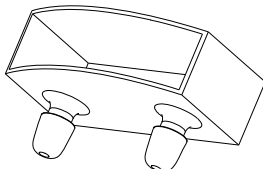
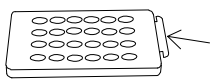
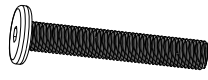
<b>A</b>		X1	<b>G</b>	 M8x60mm	X2	<b>M</b>		X16
<b>B</b>	 M8x16mm	X16	<b>H</b>		X6	<b>N</b>		X32
<b>C</b>	 M8x20mm	X8	<b>J</b>	 M8	X2	<b>P</b>		X1
<b>D</b>	 M8x25mm	X4	<b>K</b>		X1	<b>Q</b>		X1
<b>E</b>	 M8x40mm	X8	<b>L</b>		X24	<b>R</b>		X1
<b>F</b>	 M8x50mm	X2						

**1**

A x 1



E x 4



M8 x 40mm

H x 4

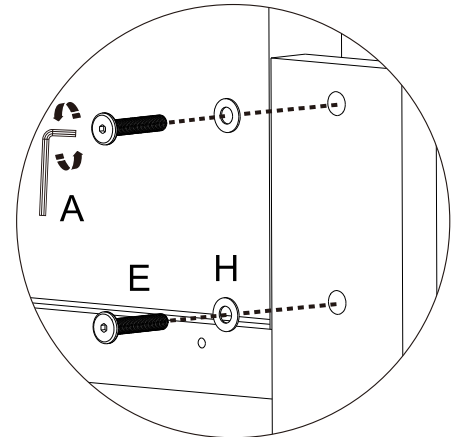
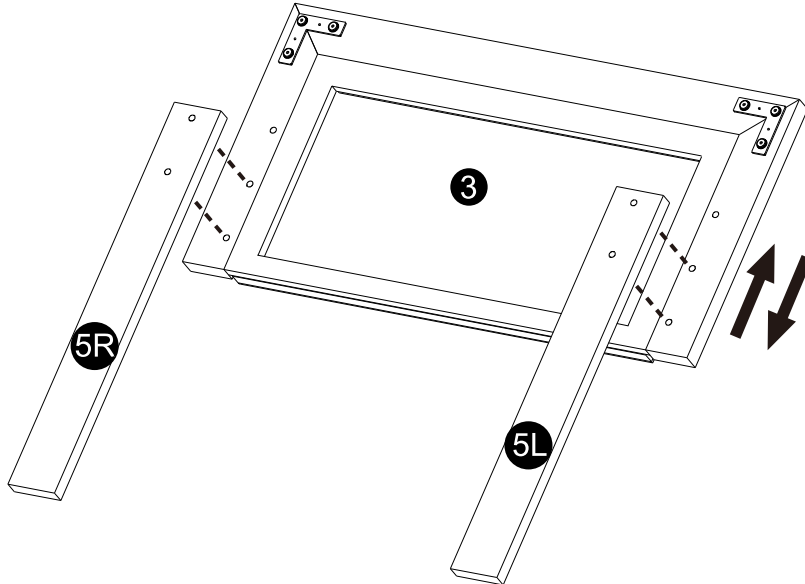

Headboard height is adjustable  
 Kopfteil ist Hohe-einstellbar  
 La hauteur de la tête de lit est réglable

**2**

A x 1



C x 4



M8 x 20mm

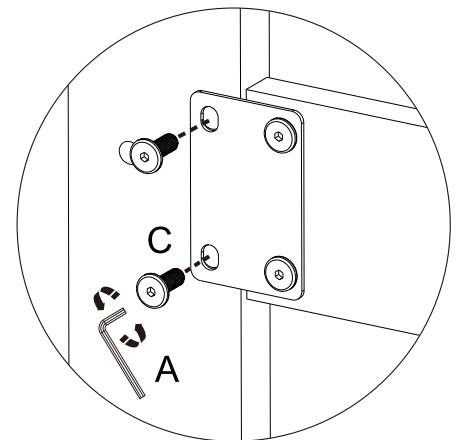
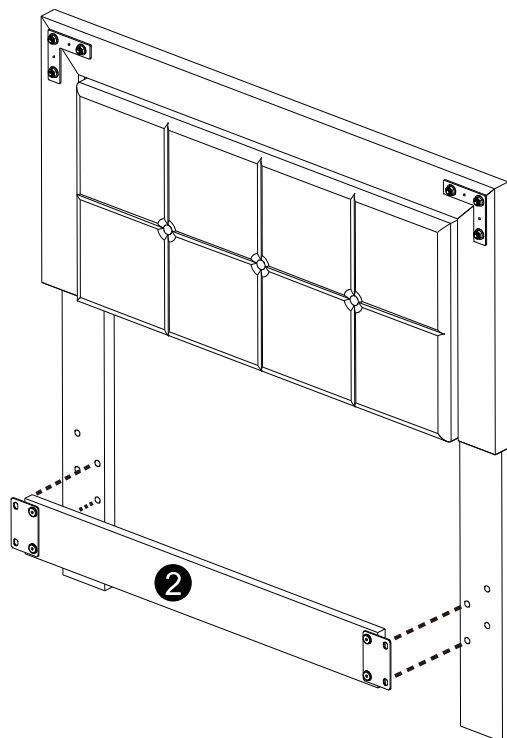

**3**

A x 1



K x 1

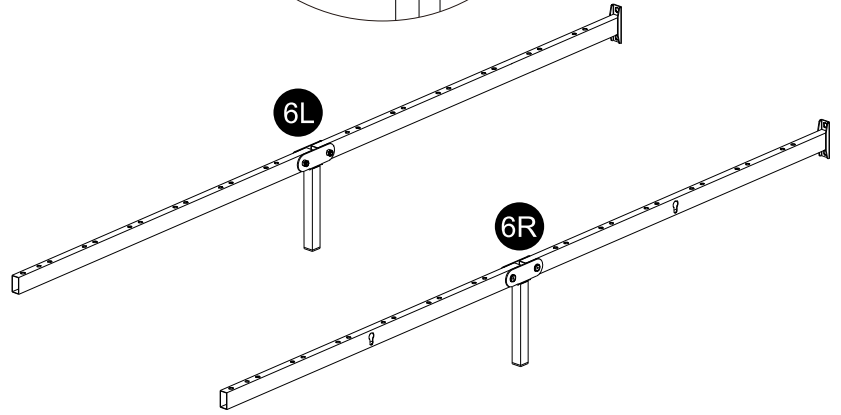
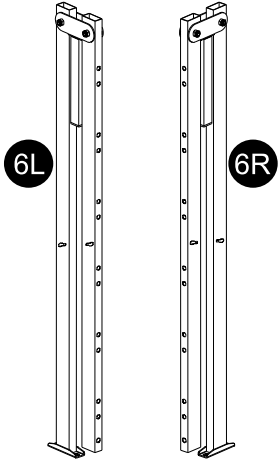
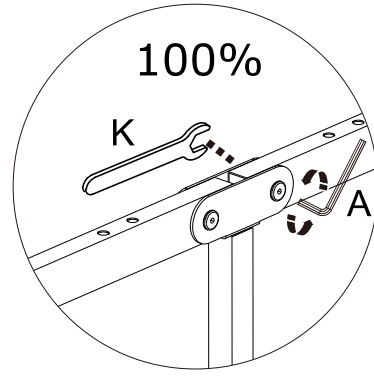

**4**

A x 1







E x 4

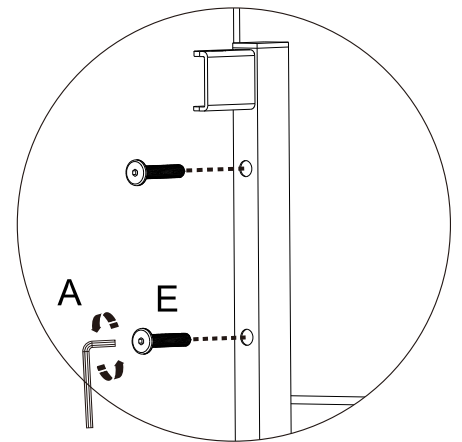
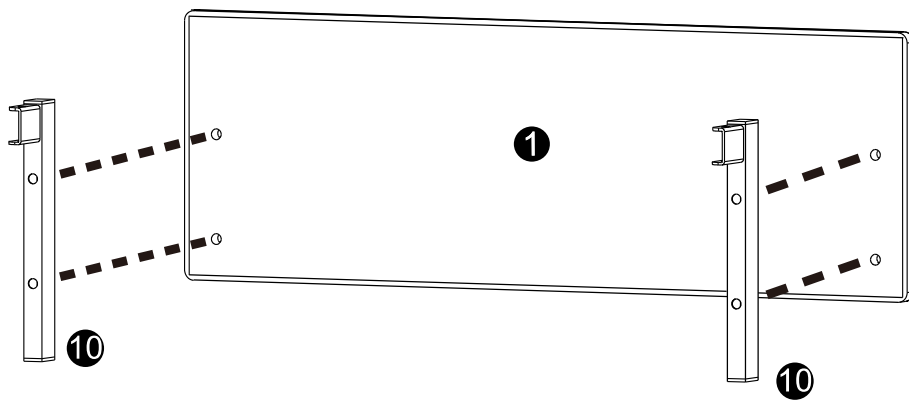

M8 x 40mm



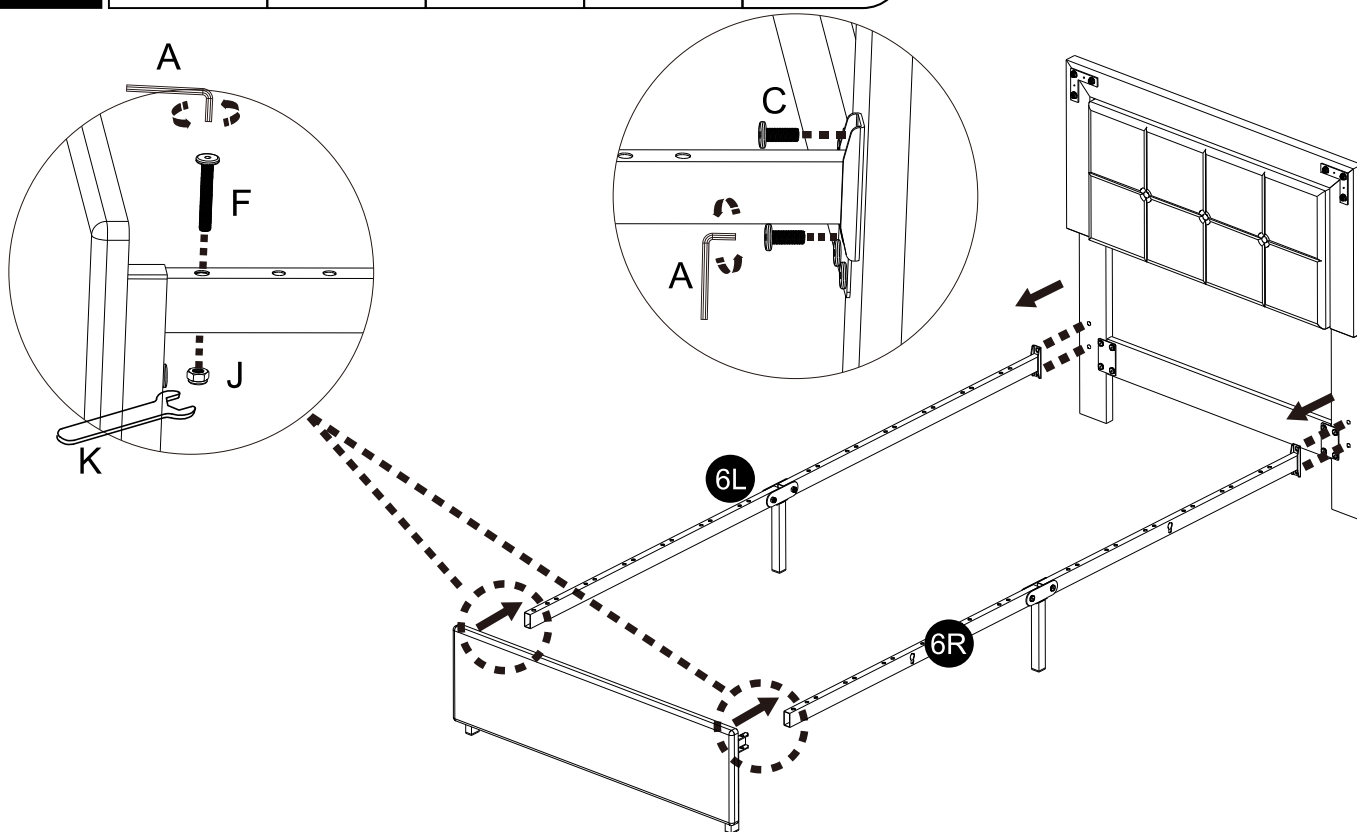

5

A x 1	C x 4	F x 2	J x 2	K x 1
				
	M8 x 20mm	M8 x 50mm	M8	



6

A x 1	G x 2	H x 2
		
	M8 x 60mm	

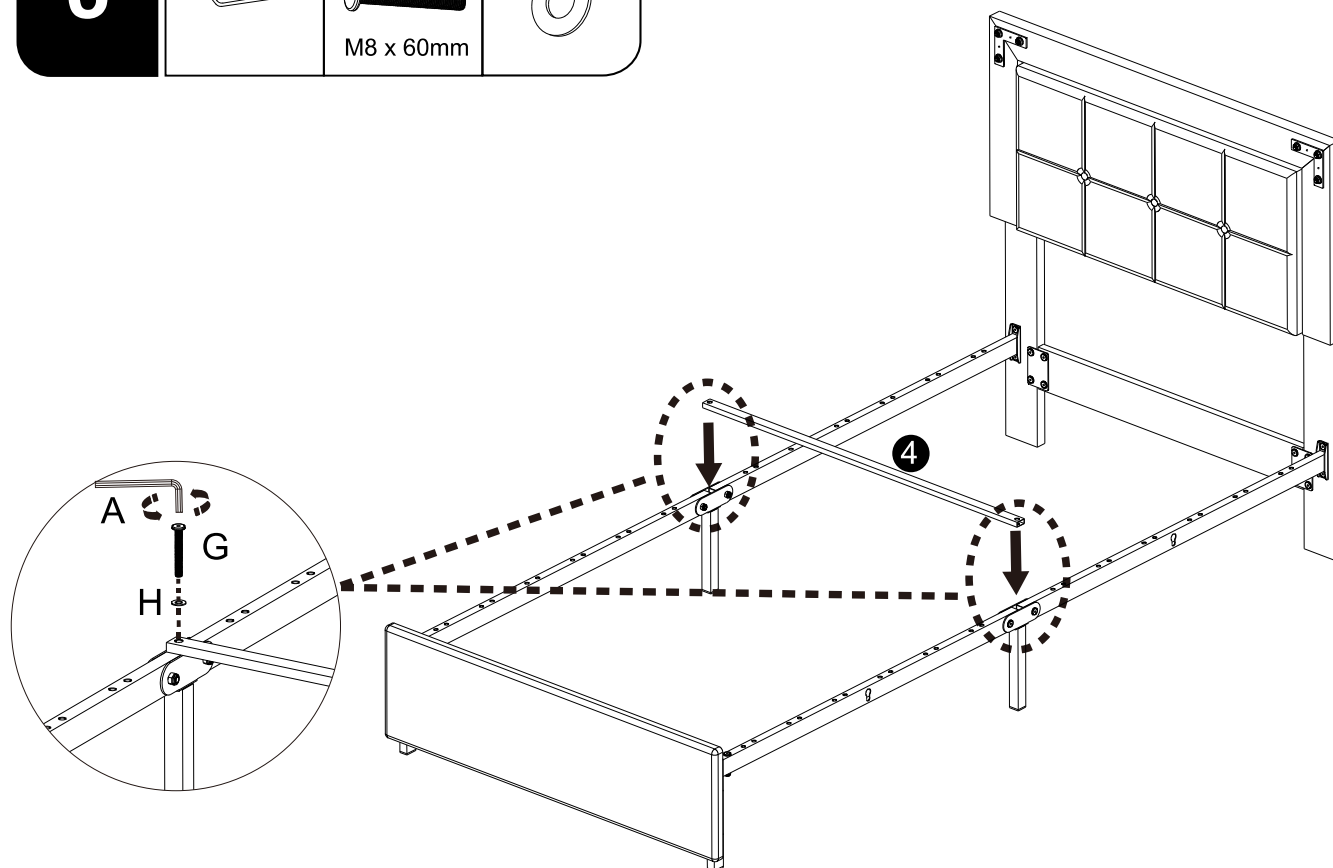

**7** L x 24

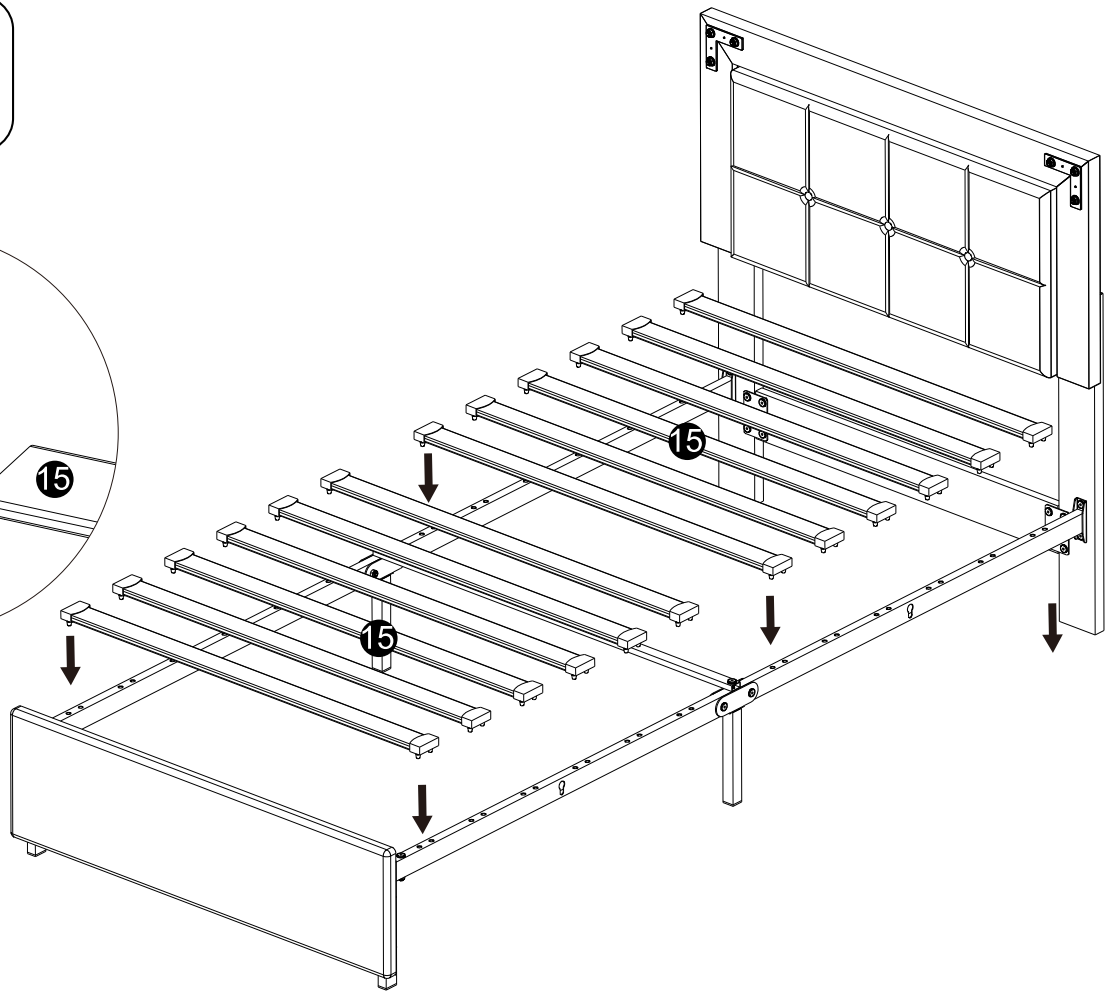
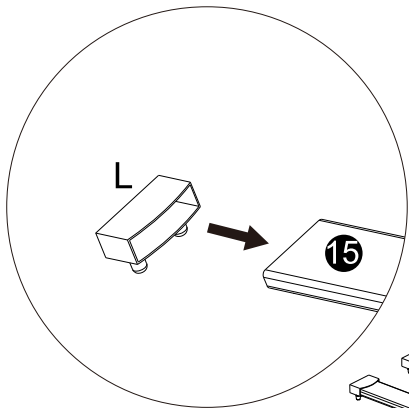
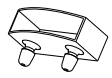

**8** N x 8



X 4

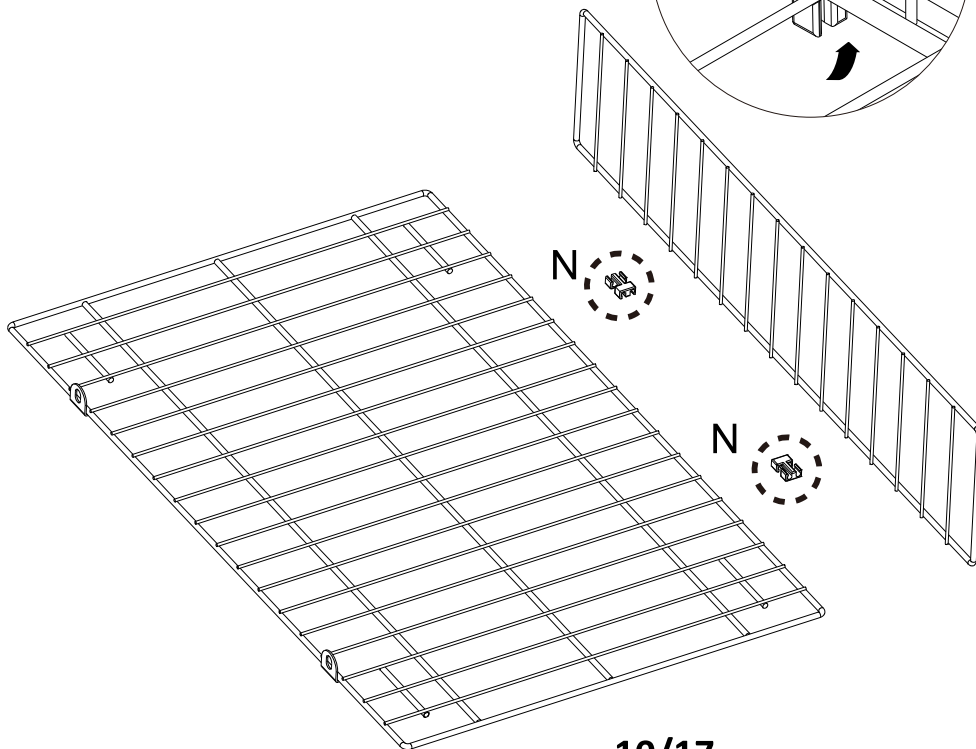
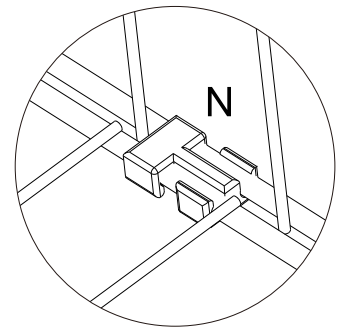
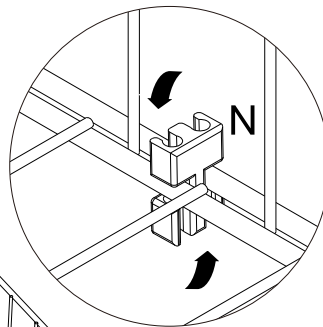

9

N x 24

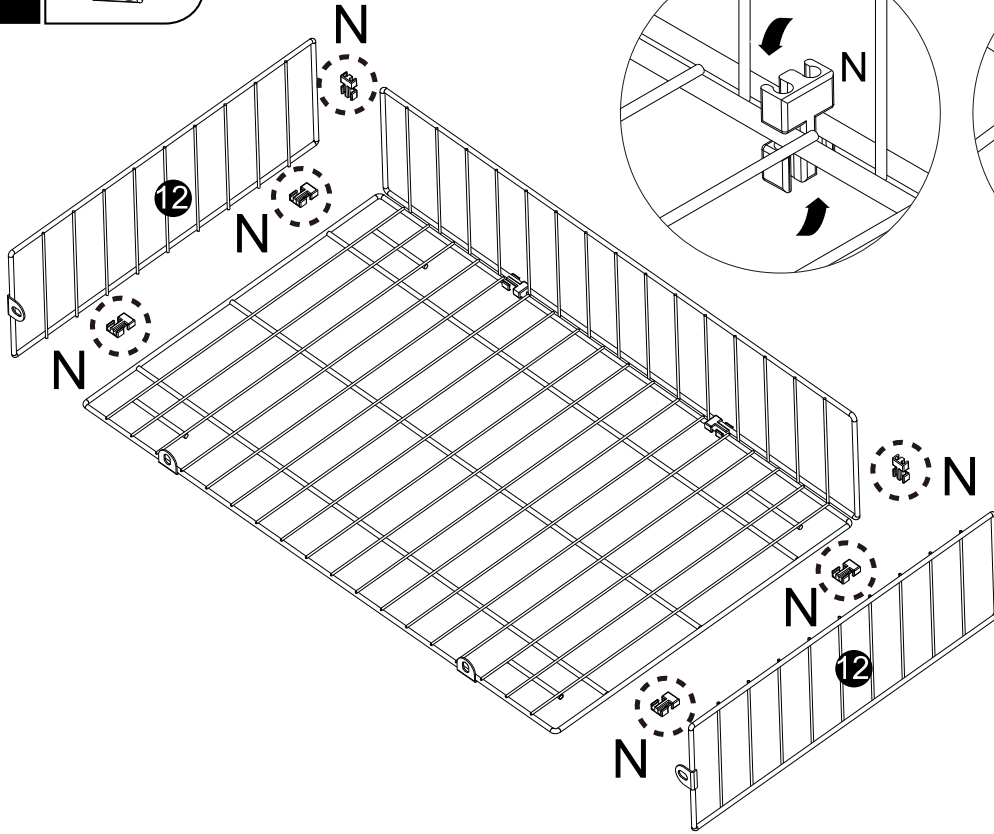

10

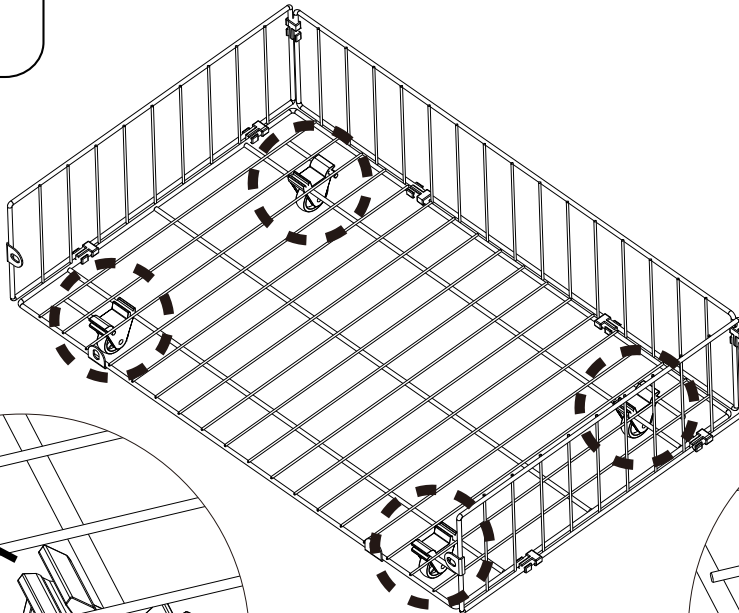

M x 16

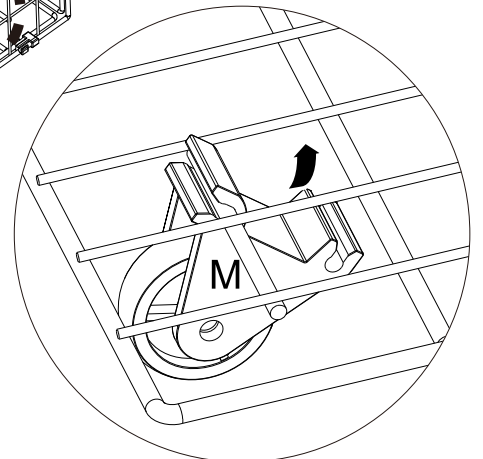
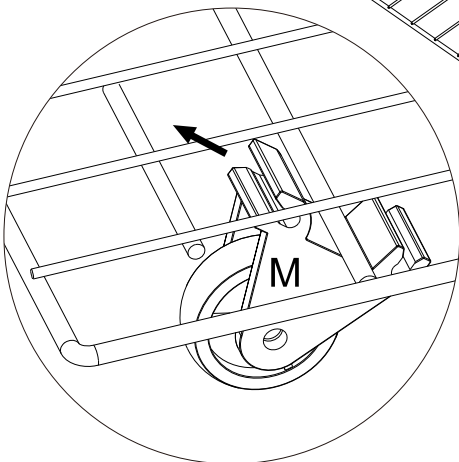

X 4



11

A x 1 	B x 16  M8 x 16mm	D x 4  M8 x 25mm
--	--	---

X 4

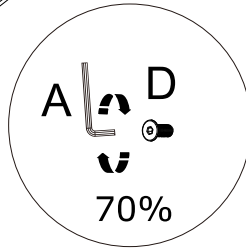
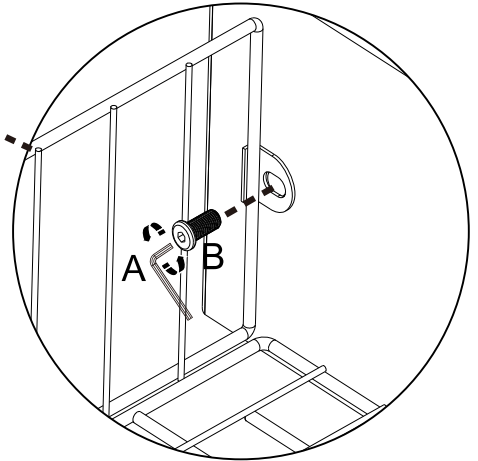
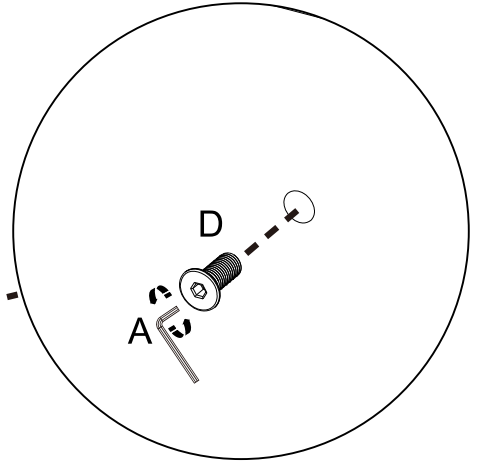
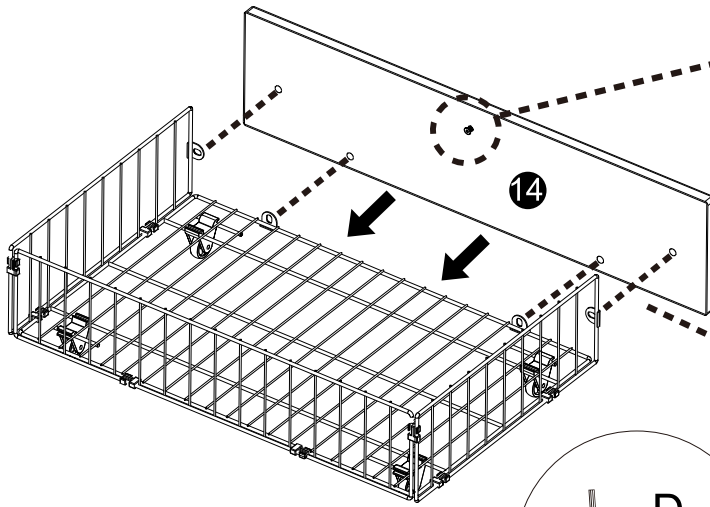

12

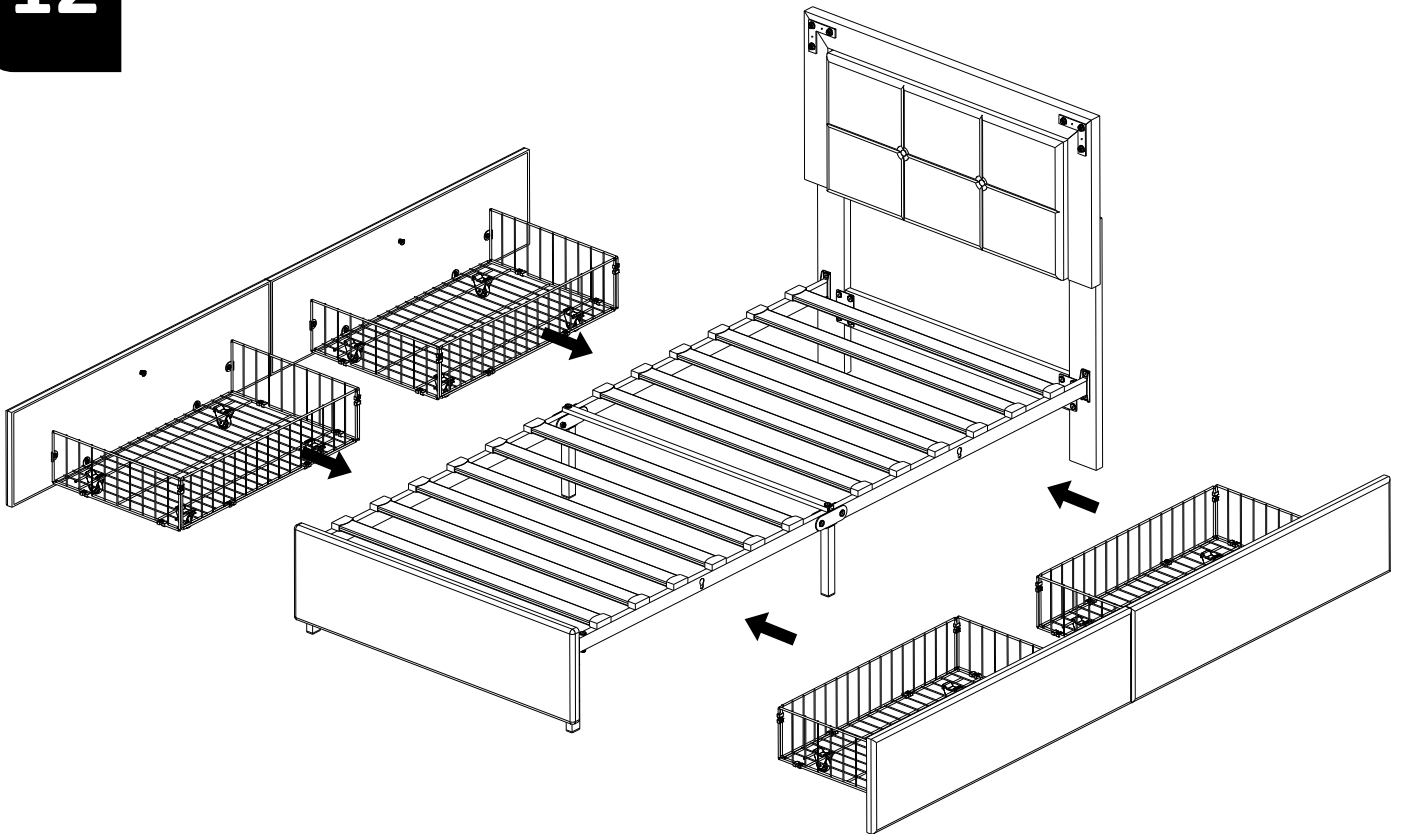

13

P x 1



Q x 1



R x 1

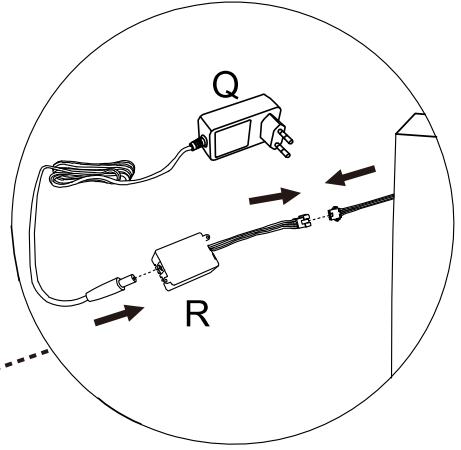
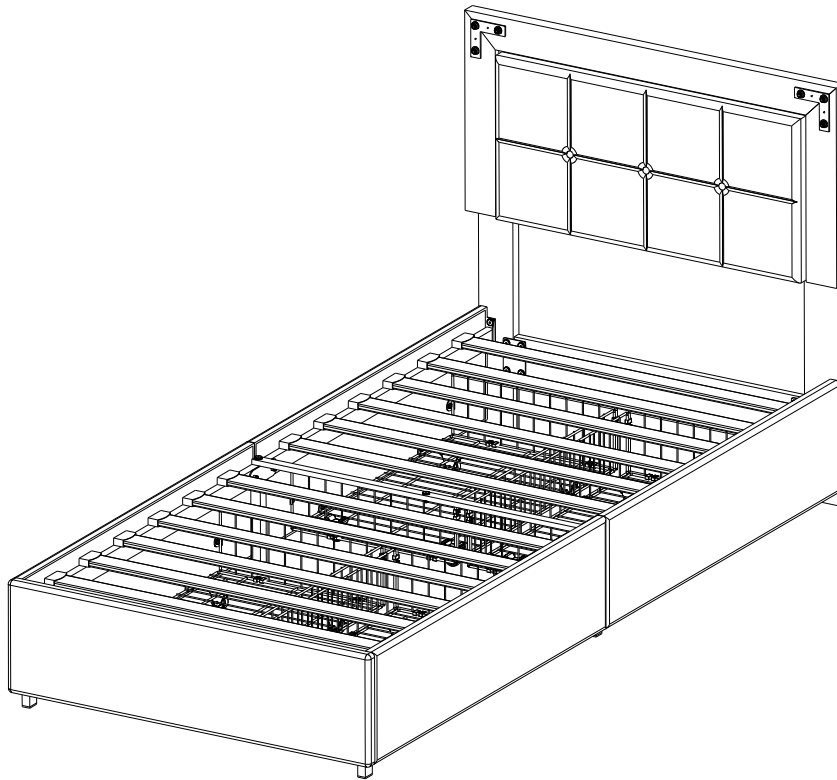
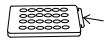

14

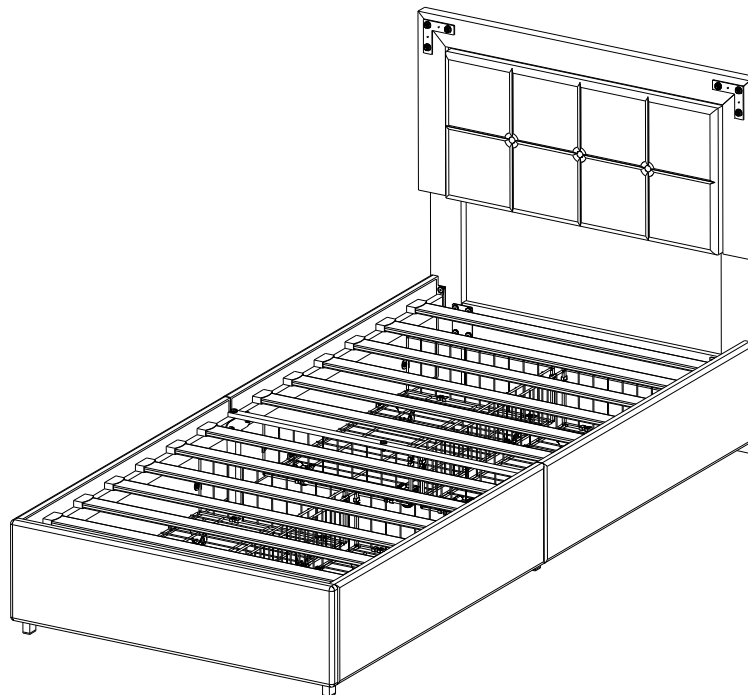

## LED light

If you can't let the lights work successfully, please check the following:

1. Please check the direction of the connect, try it in the opposite direction, according to the following picture.
2. Please ensure to tear down the plastic septum of remote control before using.
3. If one of the colors is not bright, please check whether the four wires in the plug are skewed, and move the main line to make the four wires flush.

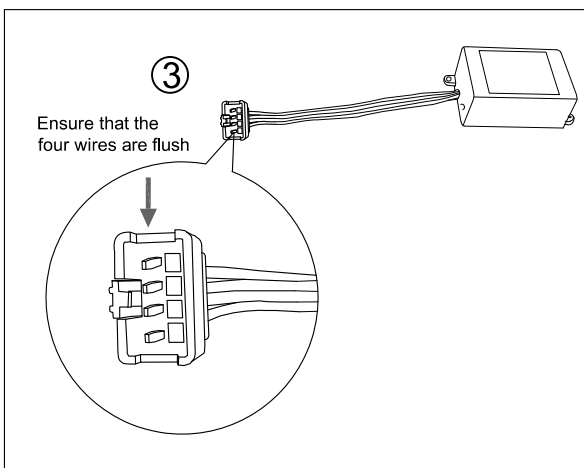
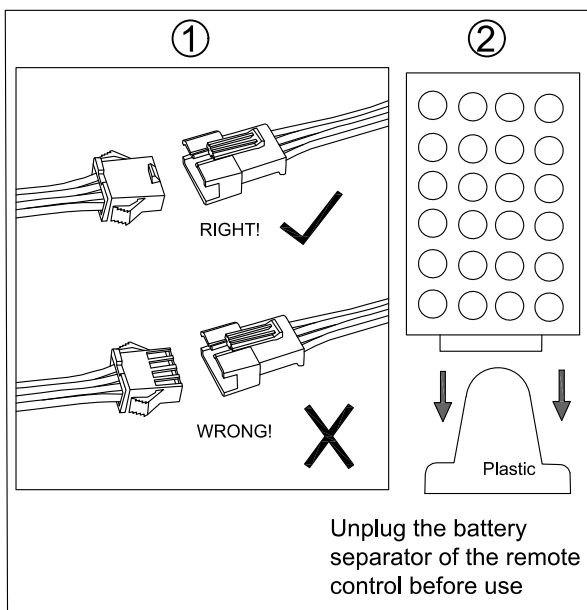

- 1 Please check the direction of the arrow
- 2 Please pull the plastic block out of the remote control
- 3 Please check whether the four wires of the plug are neat

## Operation Instructions of Controller

### I .Specifications:

Working temperature : -20-60 °C      Supply voltage: DC12V  
 Output: Three CMOS drain- open output      Connecting Mode : Common anode  
 Max load current : 2 A each color

### II .Control Method:

Adopt RF remoter to control the led controller, which has 24 buttons, the function of each button as the table below:

Brightness +(Speed up)	Brightness -(Speed down)	Off	On
Static red	Static green	Static blue	Static white
Static orange	Static pea green	Static dark blue	7 color jumpy change
Static dark yellow	Static cyan	Static brown	All fade out&fade in
Static yellow	Static light blue	Static pink	7 color fade change
Static straw yellow	Static sky blue	Static purple	3 base color jumpy

### III .Panel specification and connecting drawing as follows:

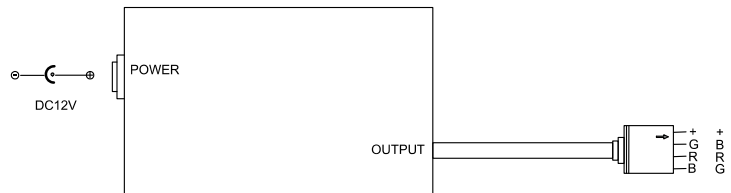

### IV .Warning:

1. Supply voltage of this product is DC12V never connect to DC24V or AC220V.
2. Never connect two wires directly in case of short circuit.
3. Lead wire should be connected correctly according to colors that connecting diagram offers.
4. Warranty of this product is one year, in this period we guarantee replacement or repairing with no charge, but exclude the artificial situation of damaged or overload working.

## ! WARNING

**THIS PRODUCT CONTAINS A BUTTON BATTERY**  
 If swallowed, a lithium button battery can cause severe or fatal injuries within 2 hours.  
 Keep batteries out of reach of children.  
 If you think batteries may have been swallowed or placed inside any part of the body, seek immediate medical attention.

# Certificate of Compliance

Certificate No.: PRMS2205006SC

**Holder** : Shenzhen Boyaxuan Technology Development Co., Ltd.  
3 / F, building 1, No.8, Xingye 1st Road, Fenghuang  
community, Fuyong Street, 518103 Shenzhen, PEOPLE'S  
REPUBLIC OF CHINA

**Manufacturer** : Shenzhen Boyaxuan Technology Development Co., Ltd.  
3 / F, building 1, No.8, Xingye 1st Road, Fenghuang  
community, Fuyong Street, 518103 Shenzhen, PEOPLE'S  
REPUBLIC OF CHINA

**Trade Mark** : N/A

**Product** : AC/DC Adapter

**Model(s)** : BYX2-XXXYYYYZ  
(‘XXX’=050 to 252, indicates 3 digit numbers which represents output  
voltage in V after diving by 10; ‘YYYY’=0010 to 4000, indicates 4 digit  
numbers which represents output current in A after diving by 1000;  
Z= E, C or blank)

**Rating** : Input: 100-240Vac, 50/60Hz, 0.5A Max.  
Output: See report

**Test Standard** : EN 62368-1:2014+A11:2017

The EUT described above has been tested by us with the listed standards and found in compliance with the council LVD directive 2014/53/EU. It is possible to use CE marking to demonstrate the compliance with this LVD Directive. It is only valid in connection with the test report number: PRMS2205006SR.



This Certificate of Conformity is based on single evaluation of the submitted sample(s) of the above mentioned product. It does not imply an assessment of the whole product and relevant . Directives have to be observed.



Shenzhen Promise Testing Technology Co., Ltd.  
103, Building 1, Yibaolai Industrial City, Qiaotou Community,  
Fuhai Street, Bao'an District, Shenzhen, Guangdong, China



# Certificate of Compliance

Certificate NO.: PRMS2205006EC01

**Holder** : Shenzhen Boyaxuan Technology Development Co., Ltd.  
3 / F, building 1, No.8, Xingye 1st Road, Fenghuang community,  
Fuyong Street, 518103 Shenzhen, PEOPLE'S REPUBLIC OF CHINA

**Manufacturer** : Same as Hodler

**Product** : AC/DC Adapter

**Model(s)** : BYX2-0504000, BYX2-2521100 (See section 2.2 of the report)

**Trade Mark** : 

**Test Standard** : EN 55032:2015/A11:2020  
EN 55035:2017/A11:2020  
EN IEC 61000-3-2:2019/A1:2021  
EN 61000-3-3:2013/A2:2021

The EUT described above has been tested by us with the listed standards and found in compliance with the council EMC Directive 2014/30/EU. It is possible to use CE marking to demonstrate the compliance with this EMC Directive. It is only valid in connection with the test report number: PRMS2205006ER-01.



Approved by



Authorized signatory May. 25, 2022

This Certificate of Conformity is based on single evaluation of the submitted sample(s) of the above mentioned product. It does not imply an assessment of the whole product and relevant Directives have to be observed.





# Certificate of Conformity

Certificate Number: DL-20240403030C

**Applicant:** Shenzhen Blue The Light Technology co., Ltd.  
Floor 4, Building 2, Hongxing Industrial Park, Yuanling Village, Shiyan Town,  
Baoan District, Shenzhen

**Manufacturer:** Shenzhen Blue The Light Technology co., Ltd.  
Floor 4, Building 2, Hongxing Industrial Park, Yuanling Village, Shiyan Town,  
Baoan District, Shenzhen

**Product:** 24 key RF RF controller

**Model No.:** LG-24-RF-12V

**Test Standard:** EN 55032:2015+A1:2020  
EN IEC 61000-3-2:2019+A1:2021, EN 61000-3-3:2013+A1:2019+A2:2021  
EN 55035:2017+A11:2020  
EN 61000-4-2:2009, EN IEC 61000-4-3:2020, EN 61000-4-4:2012,  
EN 61000-4-5:2014+A1:2017, EN IEC 61000-4-6:2022,  
EN 61000-4-8:2010, EN IEC 61000-4-11:2020

The EUT described above has been tested by us with the listed standards and found in compliance with the council EMC directive 2014/30/EU. It is possible to use CE marking to demonstrate the compliance with this EMC Directive. It is only valid in connection with the test report number: DL-20240403030E.



This certificate of conformity is based on a single evaluation of the submitted sample(s) of the above mentioned product. It does not imply an assessment of the whole product and relevant. Without the written approval, It is not permitted to use the test lab's logo.

Shenzhen DL Testing Technology Co., Ltd.  
101-201, Comprehensive Building, Tongzhou Electronics Longgang Factory Area, No.1 Baolong  
Fifth Road, Baolong Community, Baolong Street, Longgang District, Shenzhen, China  
Web: [www.dl-cert.com](http://www.dl-cert.com) E-mail: [Service@dl-cert.com](mailto:Service@dl-cert.com) Tel: 400-688-3552

