

ASSEMBLY INSTRUCTION

Model: C T 1 6 6 8

Model: Coffee table

Thank you for purchasing this quality product, be sure to check all the packing materials carefully. When you received, please pay attention to the products, which may cause deformed during the shipment.

step 1:

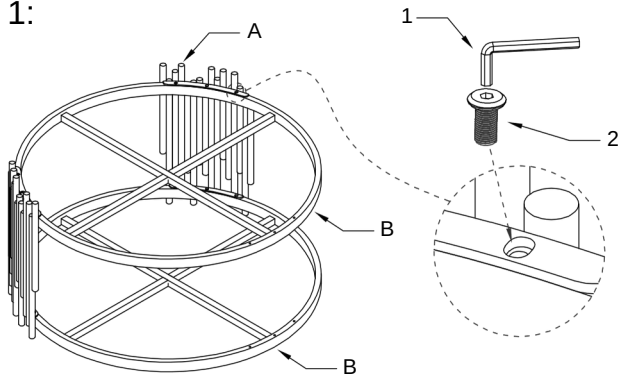

Connect Stainless steel pillar (A) with Table top frame (B) by Screw (2) Tighten turnover the whole frame (1 match 1, 2 match 2)

PART LIST

NO.	Designation	Quantity	Diagram
A	S tainless steel pillar	3	
B	Table top frame	2	
C	Table top	2	

HARDWARE LIST

NO.	Designation	Quantity	Size	Diagram
1	Allen key	1	M4	
2	Screw	18	M6*16	
3	mat	8	dia15	

step 2:

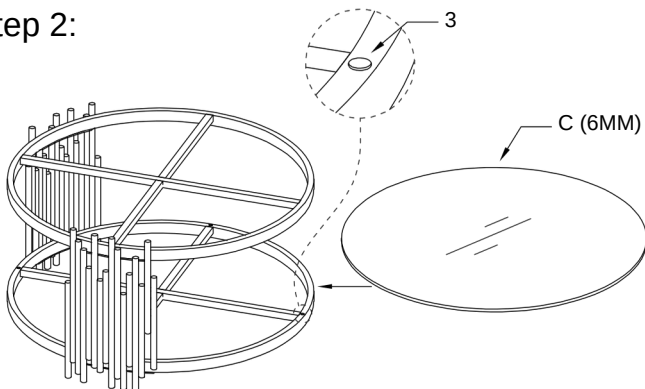

step 3:

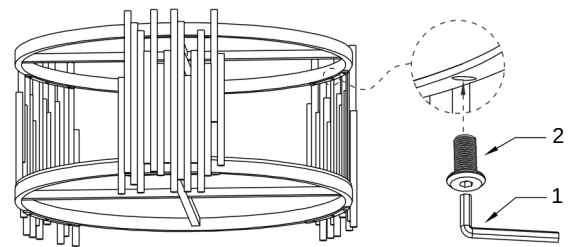

Connect Stainless steel pillar (A) with Table top frame (B) by Screw (2) Tighten turnover the whole frame

step 4:

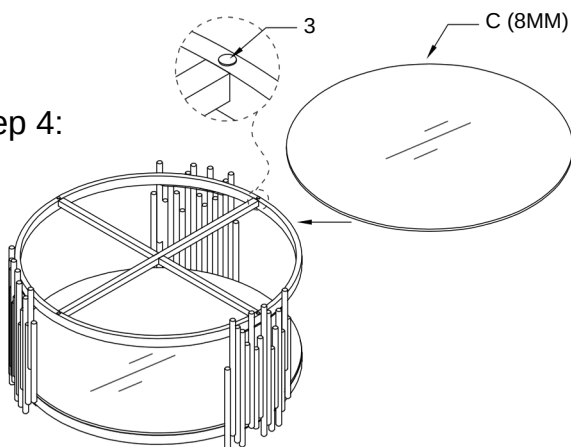

Stick the mat (3) on the Table Top frame (B). Then put the Table top (C) on the Table top frame (B)

step 5:

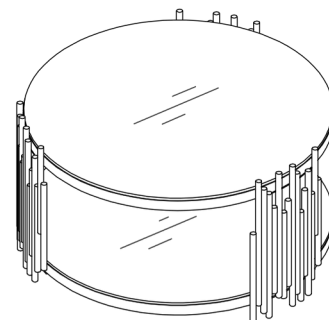

Finished

MONTAGEANLEITUNG

Modell: C T 1 6 6 8

Modell: Couchtisch

Vielen Dank für den Kauf dieses Qualitätsprodukts. Bitte überprüfen Sie beim Erhalt alle Verpackungsmaterialien sorgfältig. Achten Sie darauf, ob das Produkt während des Transports beschädigt oder verformt wurde.

Schritt 1:

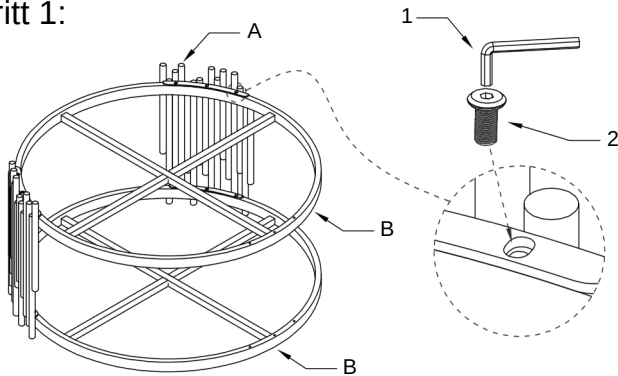

Edelstahlsäule (A) mit Tischplattenrahmen (B) mittels Schraube (2) verbinden. Das gesamte Gestell festziehen und umdrehen (1 zu 1, 2 zu 2 zuordnen).

TEILELISTE

NR.	Bezeichnung	Menge	Abbildung
A	Edelstahlsäule	3	
B	Tischrahmen	2	
C	Table top	2	

BESCHLAGLISTE

NR.	Bezeichnung	Menge	Größe	Abbildung
1	Inbus	1	M4	
2	Schraube	18	M6*16	
3	Matte	8	Ø15	

Schritt 2:

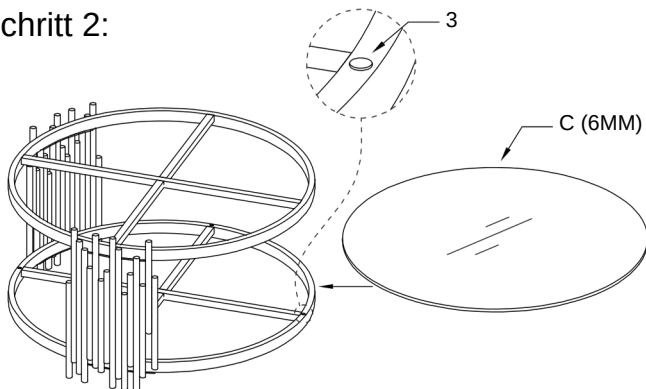

Schritt 3:

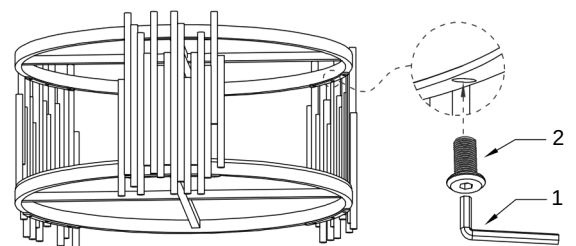

Edelstahlsäule (A) mit Tischplattenrahmen (B) mittels Schraube (2) verbinden. Das gesamte Gestell festziehen und umdrehen.

Schritt 4:

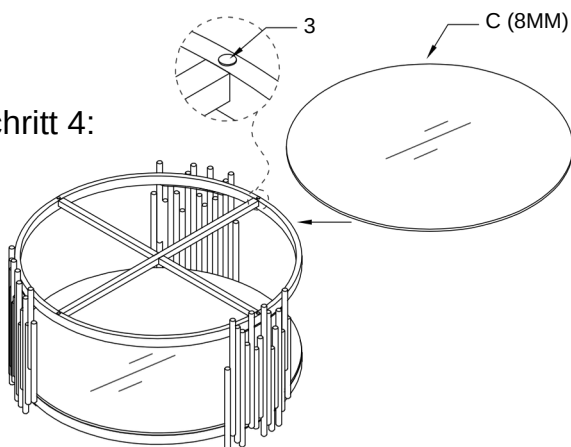

Die Gleitfüßchen/Matte (3) auf den Tischplattenrahmen (B) kleben. Dann die Tischplatte (C) auf den Tischplattenrahmen (B) legen.

step 5:

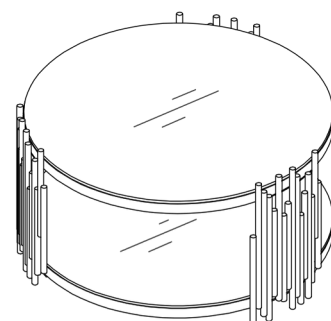

Fertig.

NOTICE DE MONTAGE

Modèle : C T 1 6 6 8

Modèle : Table basse

Merci d'avoir acheté ce produit de qualité. Veuillez vérifier attentivement tous les matériaux d'emballage lors de la réception. Portez une attention particulière au produit, qui pourrait avoir été déformé pendant le transport.

Étape 1 :

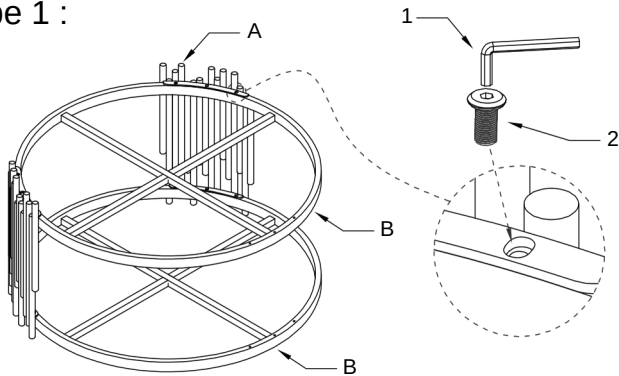

Fixez le pilier en acier inoxydable (A) au cadre du plateau (B) à l'aide de la vis (2). Serrez et retournez l'ensemble du cadre (1 correspond à 1, 2 correspond à 2).

LISTE DES PIÈCES

N°	Désignation	Quantité	Schéma
A	Pilier en acier inox	3	
B	Cadre du plateau	2	
C	Plateau	2	

LISTE DE QUINCAILLERIE

N°	Désignation	Quantité	Taille	Schéma
1	Clé Allen	1	M4	
2	Vis	18	M6*16	
3	Patin	8	Ø15	

Étape 2 :

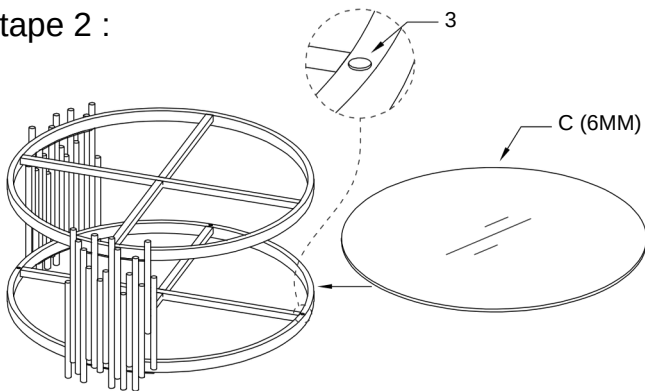

Étape 3 :

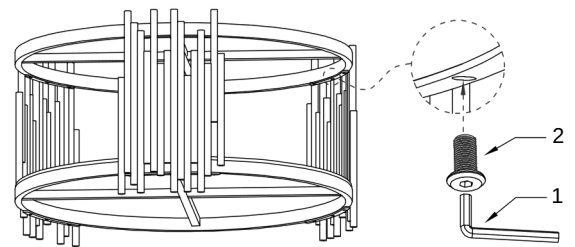

Edelstahlsäule (A) mit Tischplattenrahmen (B) mittels Schraube (2) verbinden. Das gesamte Gestell festziehen und umdrehen.

Étape 4 :

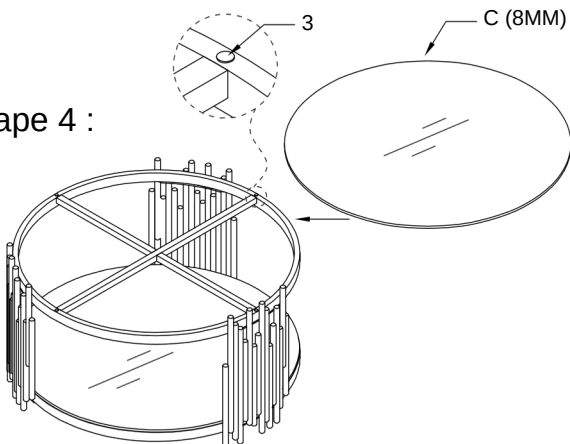

Coller les patins/semelles (3) sur le cadre du plateau (B). Puis poser le plateau (C) sur le cadre du plateau (B).

Étape 5 :

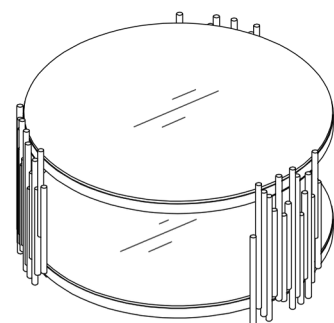

Terminé.

INSTRUCCIONES DE MONTAJE

Modelo: C T 1 6 6 8

Modelo: Mesa de centro

Gracias por adquirir este producto de calidad. Asegúrese de revisar cuidadosamente todos los materiales del embalaje al recibirlo. Preste atención al producto, ya que podría haberse deformado durante el envío.

Paso 1:

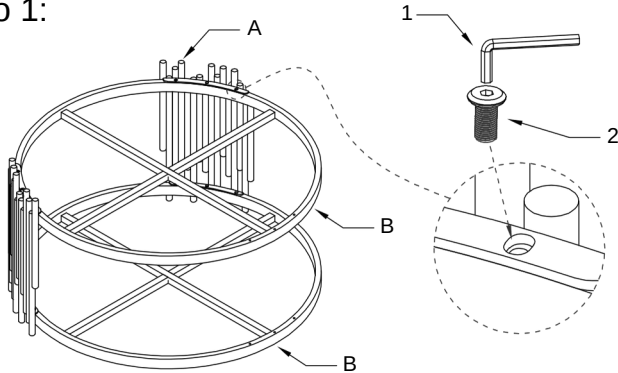

Conecte el pilar de acero inoxidable (A) con el marco del tablero (B) mediante el tornillo (2). Apriete y voltee todo el marco (1 coincide con 1, 2 coincide con 2).

LISTA DE PIEZAS

N°	Designación	Cantidad	Diagrama
A	Pilar de acero inox	3	
B	Marco del tablero	2	
C	Tablero de mesa	2	

LISTA DE HERRAMIENTAS Y FIJACIONES

N°	Designación	Cantidad	Tamaño	Diagrama
1	Llave Allen	1	M4	
2	Tornillo	18	M6*16	
3	Fieltro	8	Ø15	

Paso 2:

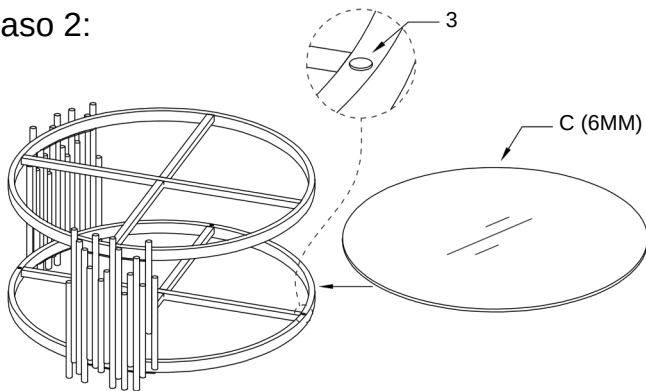

Paso 3:

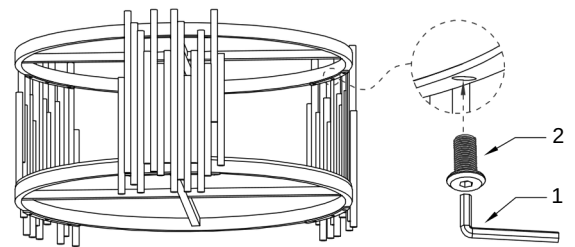

Conecte el pilar de acero inoxidable (A) con el marco del tablero (B) mediante el tornillo (2). Apriete y voltee todo el marco.

Paso 4:

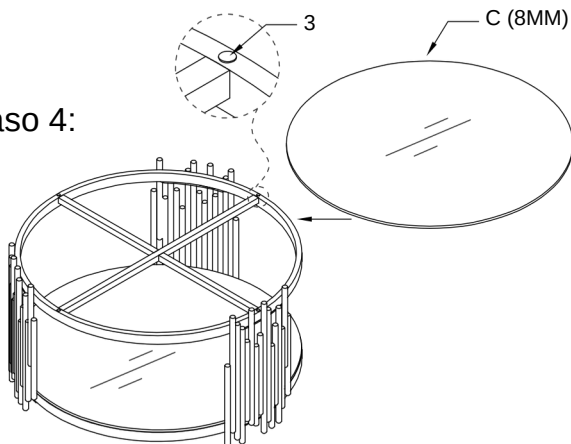

Paso 5:

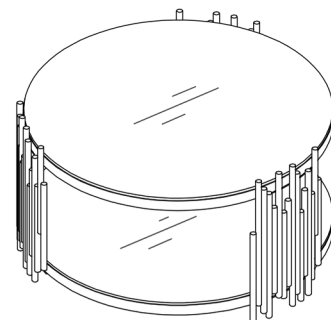

Pegar los fieltros/bases antideslizantes (3) en el marco del tablero (B). Luego colocar el tablero (C) sobre el marco del tablero (B).

Terminado.

ISTRUZIONI DI MONTAGGIO

Modello: C T 1 6 6 8

Modello: Tavolino da salotto

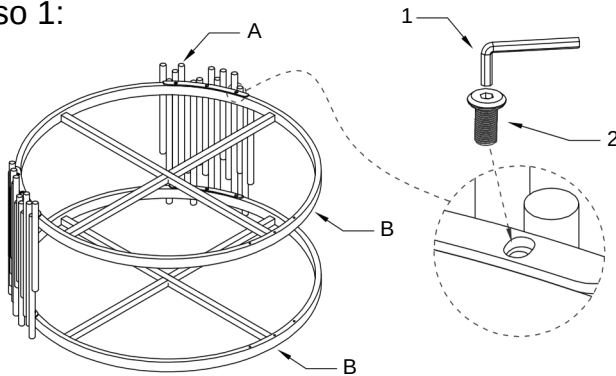

Grazie per aver acquistato questo prodotto di qualità. Assicuratevi di controllare attentamente tutti i materiali di imballaggio al momento della ricezione. Presta attenzione al prodotto, che potrebbe essersi deformato durante la spedizione.

Passo 1:





Collegare il pilastro in acciaio inossidabile (A) alla cornice del piano (B) utilizzando la vite (2). Stringere e capovolgere l'intera struttura (1 corrisponde a 1, 2 corrisponde a 2).

ELENCO COMPONENTI

N°	Designazione	Quantità	Schema
A	Pilastro in acciaio inox	3	
B	Cornice del piano	2	
C	Piano del tavolo	2	

ELENCO FERRAMENTA E ACCESSORI

N°	Designazione	Quantità	Misura	Schema
1	Chiave Allen	1	M4	
2	Vite	18	M6*16	
3	Feltro	8	Ø15	

Passo 2:

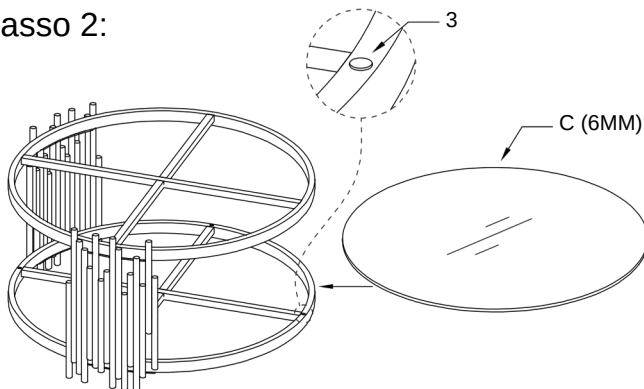

Passo 3:

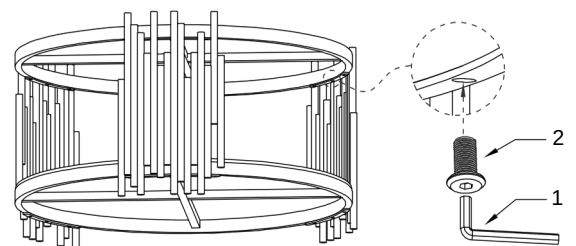

Collegare il pilastro in acciaio inossidabile (A) alla cornice del piano (B) utilizzando la vite (2). Stringere e capovolgere l'intera struttura.

Passo 4:

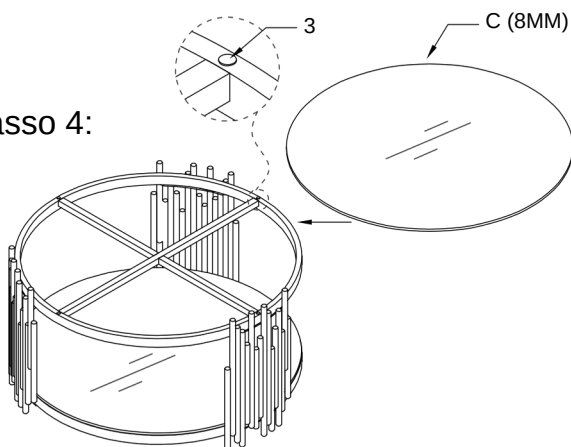

Incollare i feltri/zampette (3) sulla cornice del piano (B). Quindi posizionare il piano del tavolo (C) sulla cornice del piano (B).

Passo 5:

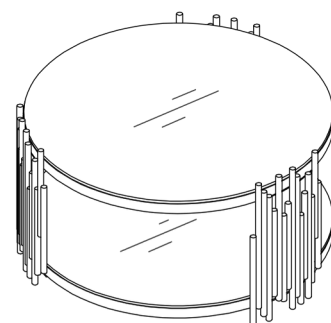

Completato.