

834-808V00  
834-808V01

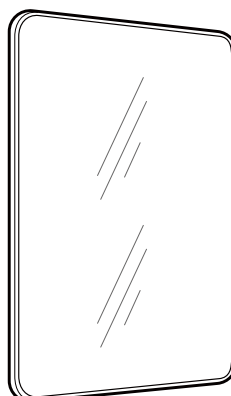

834-807V00



834-803V00  
834-803V01  
834-805V00  
834-805V01

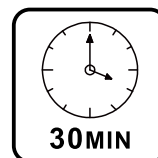
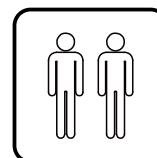
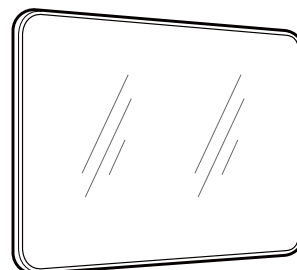

**EN\_IMPORTANT, RETAIN FOR FUTURE REFERENCE: READ CAREFULLY.**

**FR\_IMPORTANT : A LIRE ATTENTIVEMEN ET A CONSERVER POUR VOUS Y REFERER ULTERIEUREMENT.**

**ES\_IMPORTANTE, LEA Y GUARDE PARA FUTURAS REFERENCIAS.**

**PT\_IMPORTANTE, RETER PARA REFERÊNCIA FUTURA: LEIA ATENTAMENTE.**

**DE\_WICHTIG! SORGFÄLTIG LESEN UND FÜR SPÄTER NACHSCHLAGEN AUFBEWAHREN.**

**IT\_IMPORTANTE! CONSERVARE IL PRESENTE MANUALE PER FUTURO RIFERIMENTO E LEGGERLO ATTENTAMENTE.**



## Before You Start

- ⚠ Please read all instructions carefully.
- ⚠ Retain instructions for future reference.
- ⚠ Separate and count all parts and hardware.
- ⚠ Read through each step carefully and follow the proper order.
- ⚠ We recommend that, where possible, all items are assembled near to the area in which they will be placed in use, to avoid moving the product unnecessarily once assembled.
- ⚠ Always place the product on a flat, steady and stable surface.
- ⚠ Keep all small parts and packaging materials for this product away from babies and children as they potentially pose a serious choking hazard.
- ⚠ **Warning:** Indoor use only.

### CHECK PRODUCT LIST AFTER OPENING THE PACKAGE

- Mirror x1
- Screws for wall x2
- Type A Plastic Anchor x2
- Installation Manual x1
- Gloves x2

### TOOLS YOU MAY NEED



### INSTALLATION

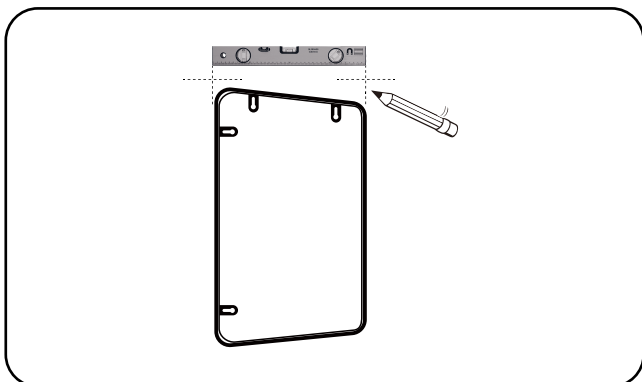

1. Measure the distance between the hanging holes on the mirror frame.

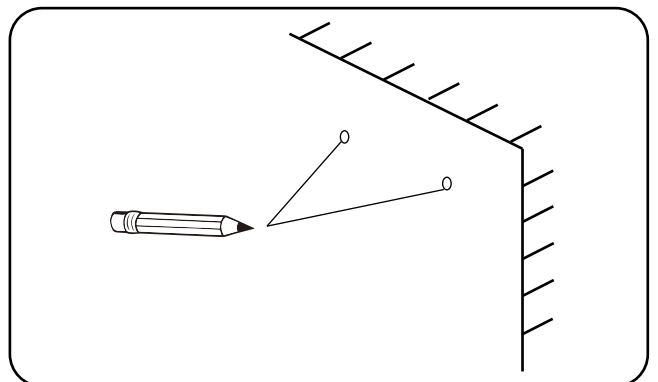

2. Mark the hole positions on the wall.

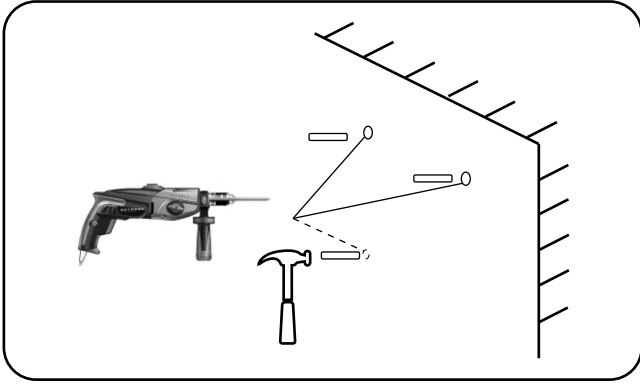

3. Drill holes and insert suitable plastic anchors, securely fastening them.

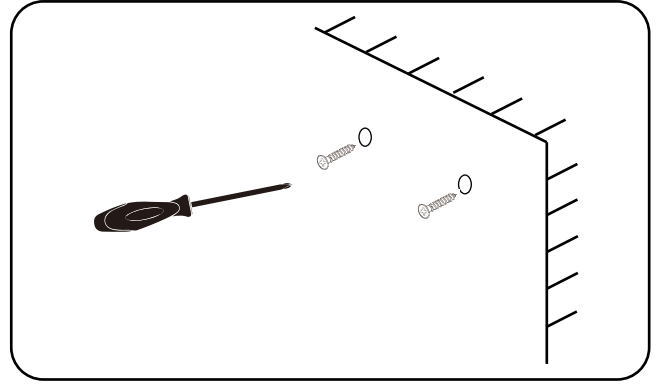

4. Arrange the screws on the wall with the screw heads protruding 5-10mm and ensure that the screws are stable.

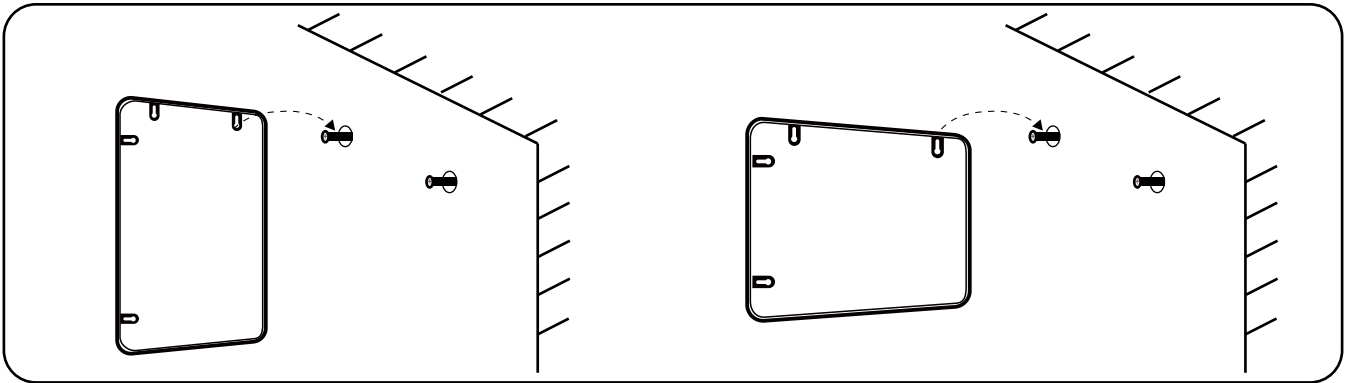

5. Hang the mirror on the screws.

## Maintenance

Use a soft dry cloth when cleaning. Do not use cleaning agents or abrasive materials. Keep moisture away from the mirror.



## Avant de commencer

- ⚠ Veuillez lire attentivement toutes les instructions.
- ⚠ Conservez les instructions pour référence future.
- ⚠ Séparez et comptez toutes les pièces et le matériel.
- ⚠ Lisez attentivement chaque étape et suivez l'ordre approprié.
- ⚠ Nous recommandons, dans la mesure du possible, que tous les articles soient assemblés près de la zone dans laquelle ils seront utilisés, afin d'éviter de déplacer inutilement le produit une fois assemblé.
- ⚠ Placez toujours le produit sur une surface plane, stable et stable.
- ⚠ Gardez toutes les petites pièces et les matériaux d'emballage de ce produit hors de portée des bébés et des enfants, car ils présentent potentiellement un risque sérieux d'étouffement.
- ⚠ **Avertissement** : Utilisation à l'intérieur uniquement.

### VÉRIFIEZ LA LISTE DES PRODUITS APRÈS AVOIR OUVERT L'EMBALLAGE

- Miroir x1
- Vis pour mur x2
- Ancrage en plastique de type A x2
- Manuel d'installation x1
- Gants x2

### OUTILS DONT VOUS POURRIEZ AVOIR BESOIN



### INSTALLATION

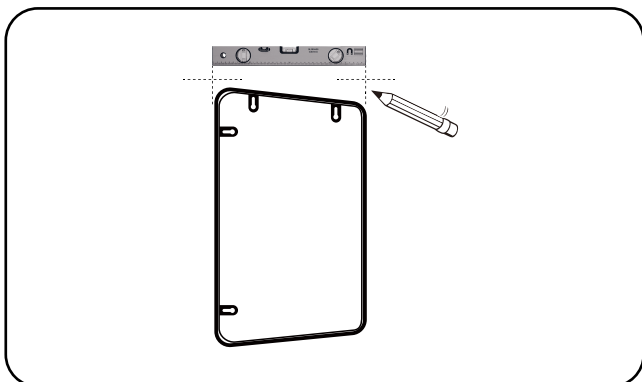

1. Mesurez la distance entre les trous de suspension sur le cadre du miroir.

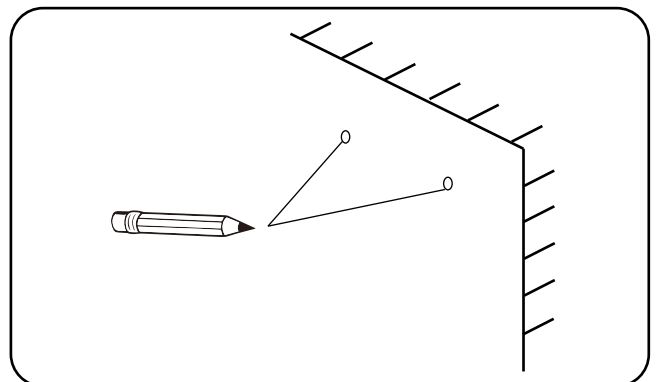

2. Marquez l'emplacement des trous sur le mur.

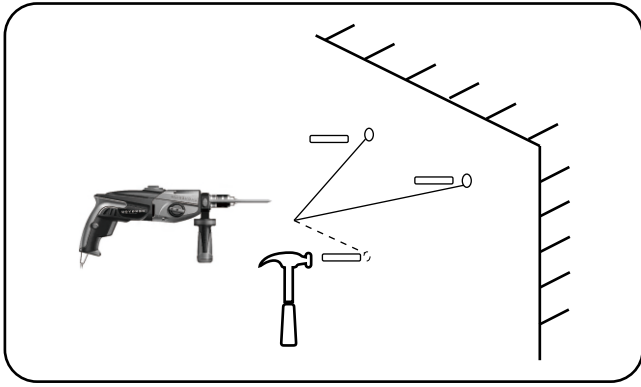

3. Percez des trous et insérez des ancrages en plastique appropriés, en les fixant solidement.

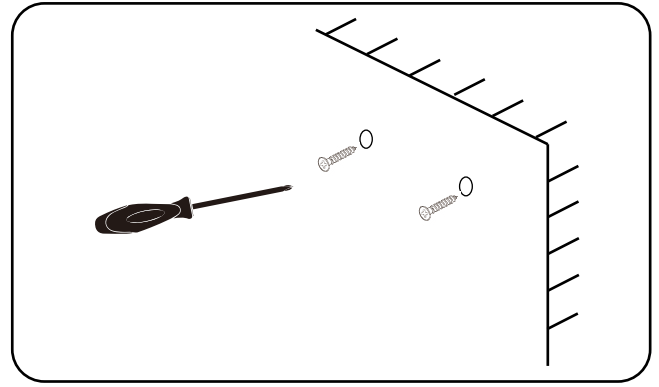

4. Disposez les vis sur le mur avec les têtes de vis saillantes de 5 à 10 mm et assurez-vous que les vis sont stables.

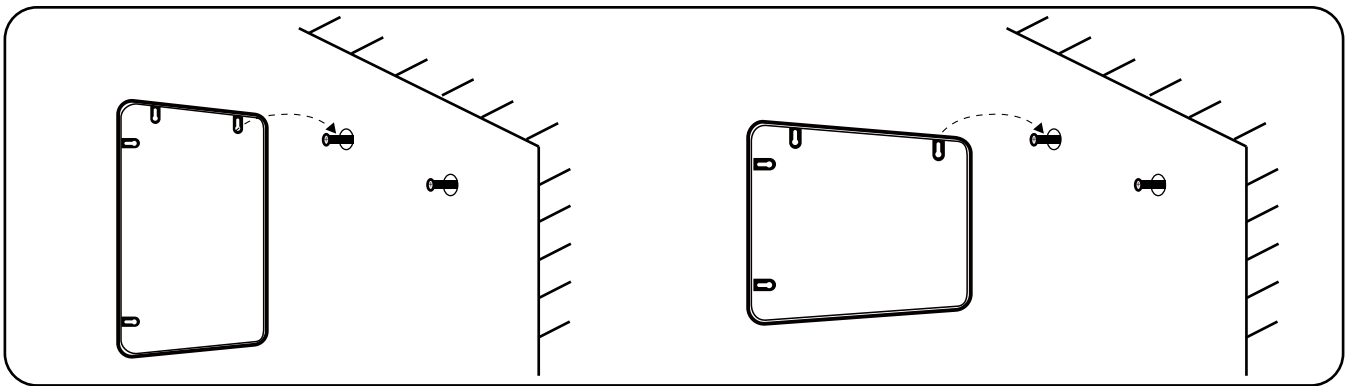

5. Accrochez le miroir sur les vis.

## Entretien

Utilisez un chiffon doux et sec pour le nettoyage. N'utilisez pas de produits de nettoyage ou de matériaux abrasifs. Gardez l'humidité loin du miroir.



Adresses sur [quefairedemesdechets.fr](http://quefairedemesdechets.fr)



## Antes de empezar

- ⚠ Por favor, lea atentamente todas las instrucciones.
- ⚠ Conserve las instrucciones para futuras consultas.
- ⚠ Separe y cuente todas las piezas y herrajes.
- ⚠ Lea atentamente cada paso y siga el orden correcto.
- ⚠ Recomendamos que, en la medida de lo posible, todos los artículos se ensamblen cerca de la zona en la que se van a colocar en uso, para evitar mover el producto innecesariamente una vez montado.
- ⚠ Coloque siempre el producto sobre una superficie plana, firme y estable.
- ⚠ Mantenga todas las piezas pequeñas y los materiales de embalaje de este producto fuera del alcance de los bebés y los niños, ya que pueden representar un grave peligro de asfixia.
- ⚠ **Advertencia:** Solo para uso en interiores.

### VERIFIQUE LA LISTA DE PRODUCTOS DESPUÉS DE ABRIR EL PAQUETE

- Espejo x1
- Tornillos para pared x2
- Anclaje de plástico tipo A x2
- Manual de instalación x1
- Guantes x2

### HERRAMIENTAS QUE PUEDE NECESITAR



### INSTALACIÓN

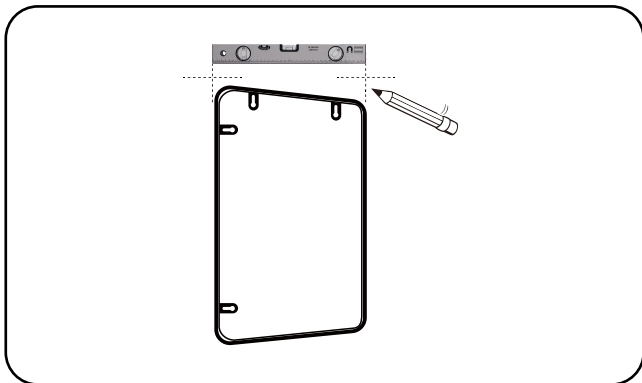

1. Mida la distancia entre los orificios para colgar en el marco del espejo.

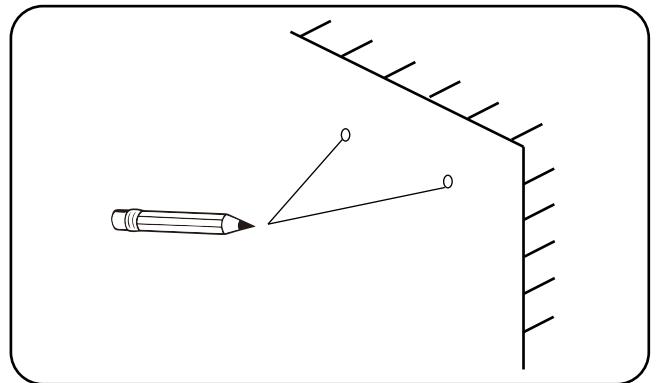

2. Marque las posiciones de los agujeros en la pared.

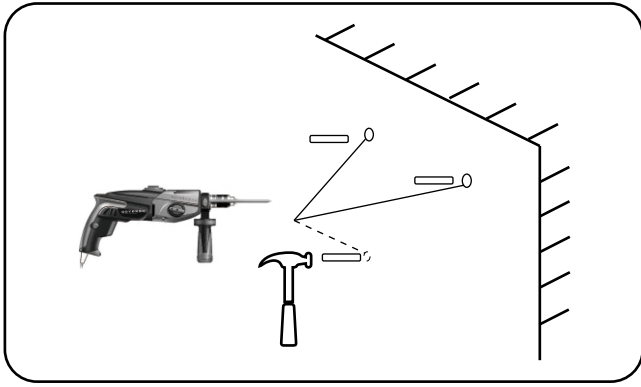

3. Taladre agujeros e inserte anclajes de plástico adecuados, fijándolos de forma segura.

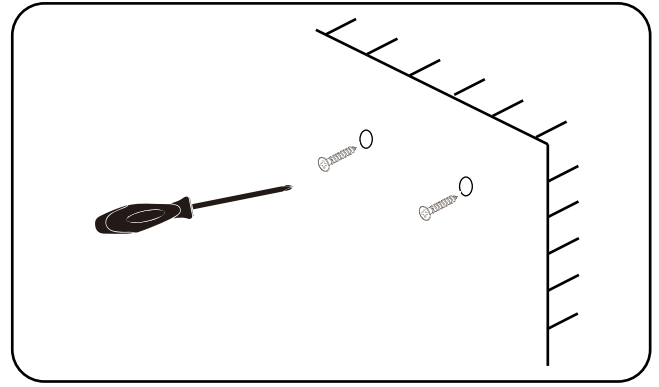

4. Coloque los tornillos en la pared con las cabezas de los tornillos que sobresalgan de 5 a 10 mm y asegúrese de que los tornillos estén estables.

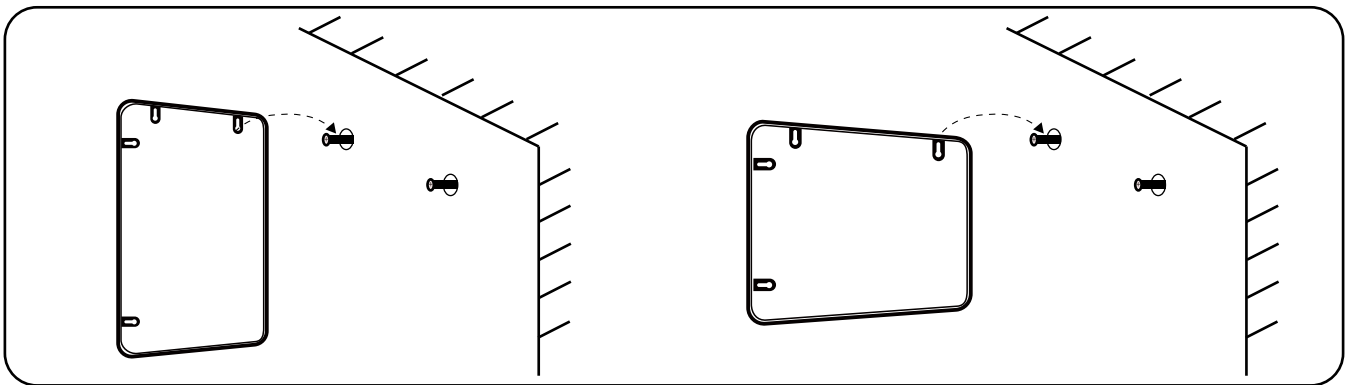

5. Cuelgue el espejo en los tornillos.

## Mantenimiento

Utilice un paño suave y seco cuando limpie. No utilice productos de limpieza ni materiales abrasivos. Mantenga la humedad alejada del espejo.



## Antes de começar

- ⚠ Por favor, leia atentamente todas as instruções.
- ⚠ Guarde as instruções para referência futura.
- ⚠ Separe e conte todas as peças e hardware.
- ⚠ Leia atentamente cada passo e siga a ordem correta.
- ⚠ Recomendamos que, sempre que possível, todos os itens sejam montados perto da área em que serão colocados em uso, para evitar mover o produto desnecessariamente uma vez montado.
- ⚠ Coloque sempre o produto numa superfície plana, estável e estável.
- ⚠ Mantenha todas as peças pequenas e materiais de embalagem para este produto longe de bebés e crianças, uma vez que representam potencialmente um sério risco de asfixia.
- ⚠ **Aviso:** Apenas para utilização no interior.

### VERIFIQUE A LISTA DE PRODUTOS DEPOIS DE ABRIR A EMBALAGEM

- Espelho x1
- Parafusos para parede x2
- Âncora de plástico tipo A x2
- Manual de Instalação x1
- Luvas x2

### FERRAMENTAS DE QUE PODERÁ NECESSITAR



### INSTALAÇÃO

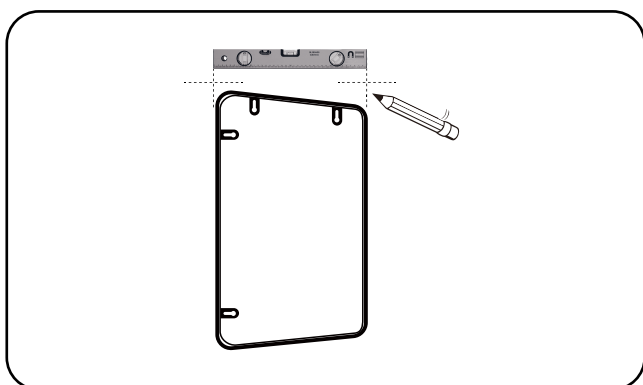

1. Meça a distância entre os orifícios suspensos na moldura do espelho.

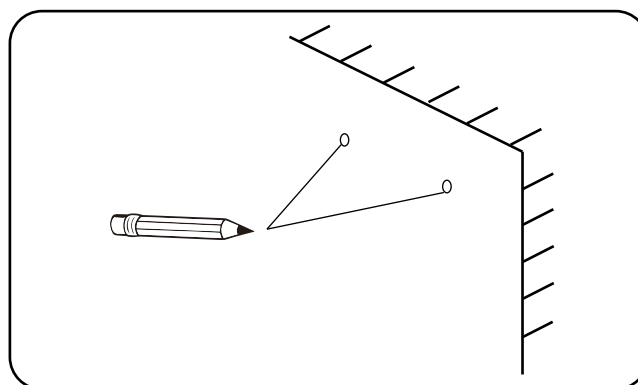

2. Marque as posições do furo na parede.

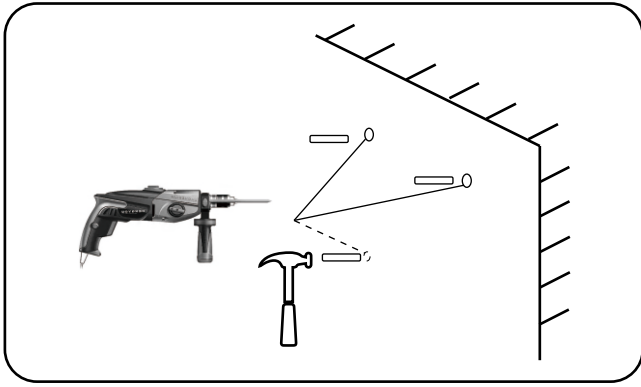

3. Faça furos e insira ancoragens de plástico adequadas, fixando-as com segurança.

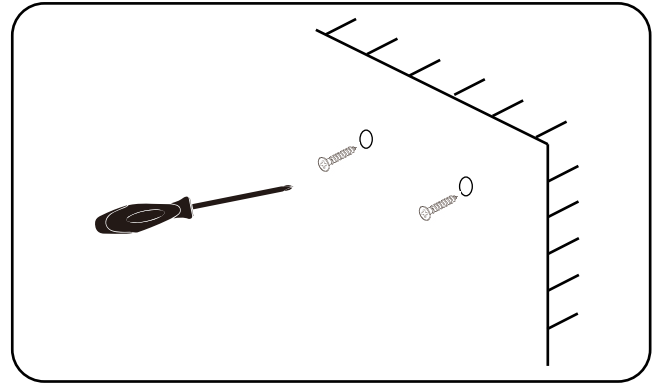

4. Disponha os parafusos na parede com as cabeças dos parafusos salientes 5-10mm e certifique-se de que os parafusos são estáveis.

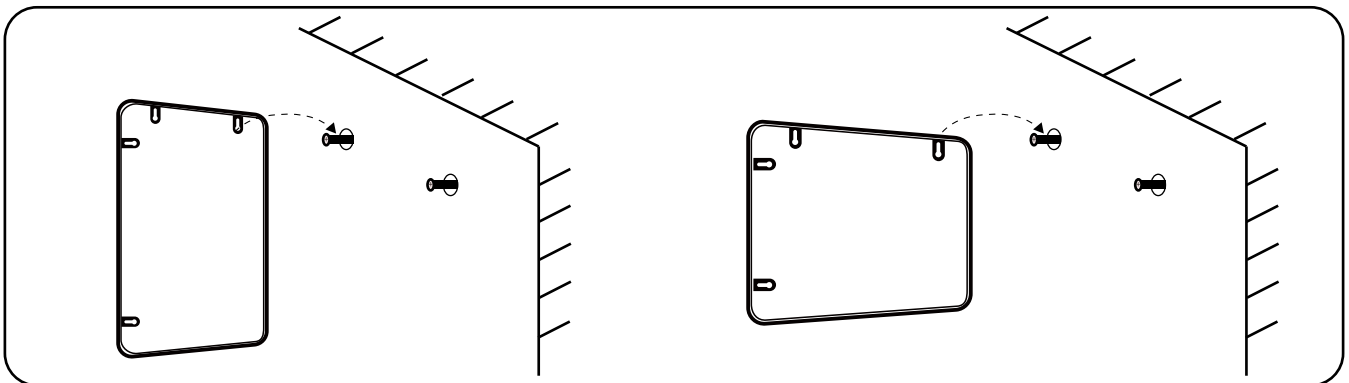

5. Pendure o espelho nos parafusos.

## Manutenção

Use um pano macio e seco ao limpar. Não utilize agentes de limpeza ou materiais abrasivos. Mantenha a humidade afastada do espelho.



## Bevor Sie beginnen

- ⚠ Bitte lesen Sie alle Anweisungen sorgfältig durch.
- ⚠ Bewahren Sie Anweisungen zum späteren Nachschlagen auf.
- ⚠ Trennen und zählen Sie alle Teile und Hardware.
- ⚠ Lesen Sie jeden Schritt sorgfältig durch und halten Sie sich an die richtige Reihenfolge.
- ⚠ Wir empfehlen, dass alle Artikel nach Möglichkeit in der Nähe des Bereichs montiert werden, in dem sie verwendet werden, um unnötige Bewegungen des Produkts nach dem Zusammenbau zu vermeiden.
- ⚠ Stellen Sie das Produkt immer auf eine ebene, stabile und stabile Oberfläche.
- ⚠ Halten Sie alle Kleinteile und Verpackungsmaterialien für dieses Produkt von Babys und Kindern fern, da sie möglicherweise eine ernsthafte Erstickungsgefahr darstellen.
- ⚠ **Warnung:** Nur für den Innenbereich geeignet.

### ÜBERPRÜFEN SIE DIE PRODUKTLISTE NACH DEM ÖFFNEN DER VERPACKUNG

- Spiegel x1
- Schrauben für Wand x2
- Kunststoffanker Typ A x2
- Installationsanleitung x1
- Handschuhe x2

### WERKZEUGE, DIE SIE MÖGLICHERWEISE BENÖTIGEN



### INSTALATION

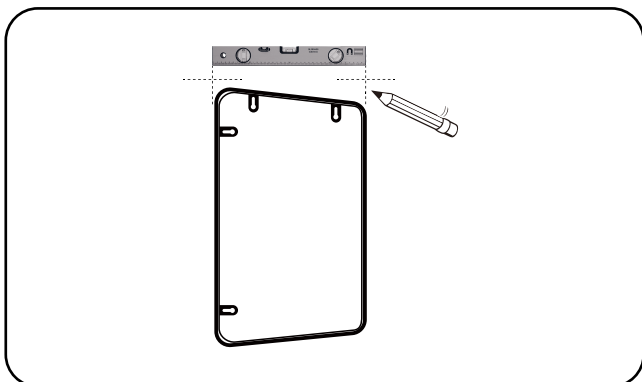

1. Messen Sie den Abstand zwischen den Aufhängelöchern am Spiegelrahmen.

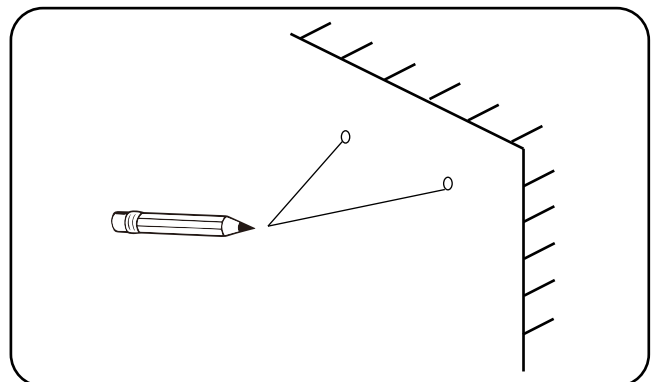

2. Markieren Sie die Lochpositionen an der Wand.

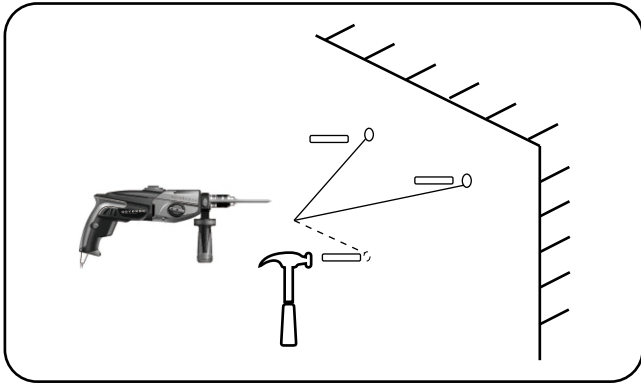

3. Bohren Sie Löcher und setzen Sie geeignete Kunststoffdübel ein und befestigen Sie diese sicher.

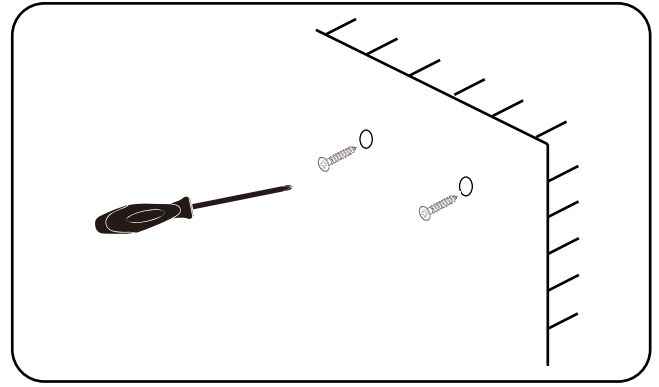

4. Ordnen Sie die Schrauben mit den 5-10mm überstehenden Schraubenköpfen an der Wand an und achten Sie darauf, dass die Schrauben stabil stehen.

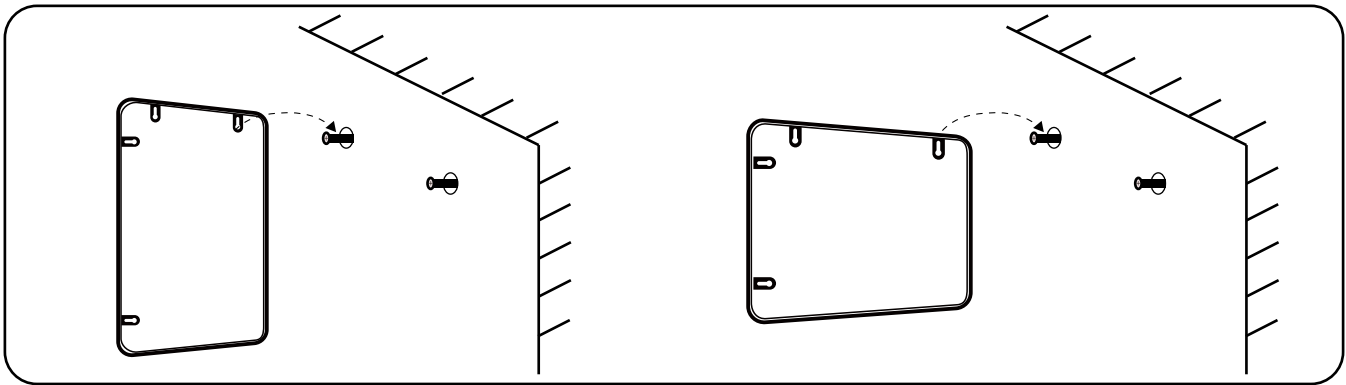

5. Hängen Sie den Spiegel an die Schrauben.

## Instandhaltung

Verwenden Sie zum Reinigen ein weiches, trockenes Tuch. Verwenden Sie keine Reinigungsmittel oder Scheuermittel. Halten Sie Feuchtigkeit vom Spiegel fern.



## Prima di iniziare

- ⚠ Si prega di leggere attentamente tutte le istruzioni.
- ⚠ Conservare le istruzioni per riferimento futuro.
- ⚠ Separare e contare tutte le parti e l'hardware.
- ⚠ Leggi attentamente ogni passaggio e segui l'ordine corretto.
- ⚠ Si consiglia che, ove possibile, tutti gli articoli siano assemblati vicino all'area in cui verranno messi in uso, per evitare di spostare inutilmente il prodotto una volta assemblato.
- ⚠ Posizionare sempre il prodotto su una superficie piana, stabile e stabile.
- ⚠ Tenere tutte le piccole parti e i materiali di imballaggio di questo prodotto lontano dalla portata di neonati e bambini in quanto rappresentano potenzialmente un grave rischio di soffocamento.
- ⚠ **Attenzione:** Solo per uso interno.

### CONTROLLA L'ELENCO DEI PRODOTTI DOPO AVER APERTO LA CONFEZIONE

- Specchio x1
- Viti per parete x2
- Ancoraggio in plastica di tipo A x2
- Manuale di installazione x1
- Guanti x2

### STRUMENTI DI CUI POTRESTI AVER BISOGNO



### INSTALLAZIONE

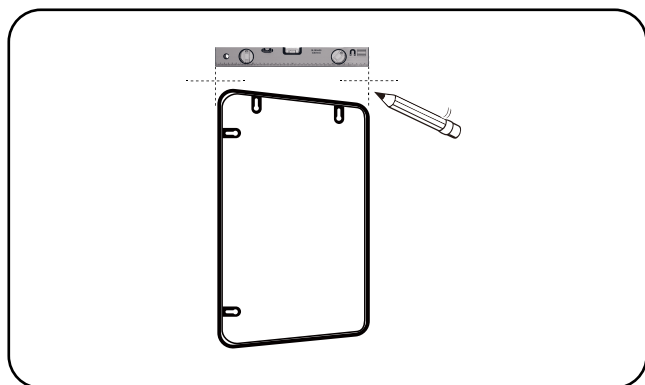

1. Misurare la distanza tra i fori di sospensione sulla cornice dello specchio.

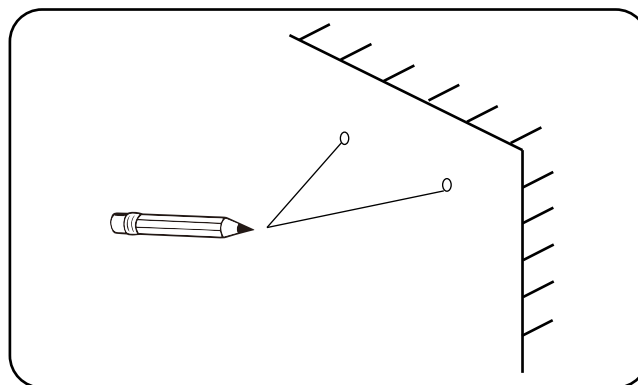

2. Segnare le posizioni dei fori sulla parete.

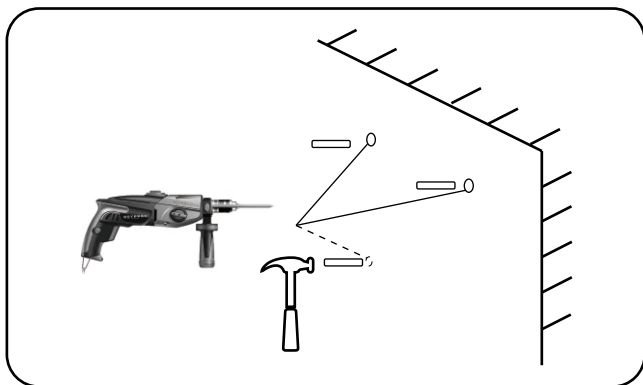

3. Praticare dei fori e inserire tasselli di plastica adatti, fissandoli saldamente.

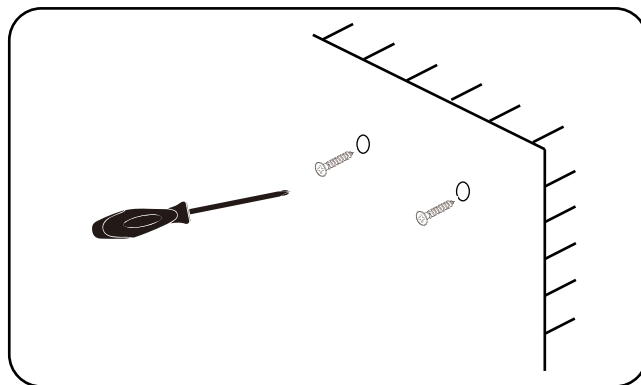

4. Disporre le viti sulla parete con le teste delle viti sporgenti di 5-10 mm e assicurarsi che le viti siano stabili.

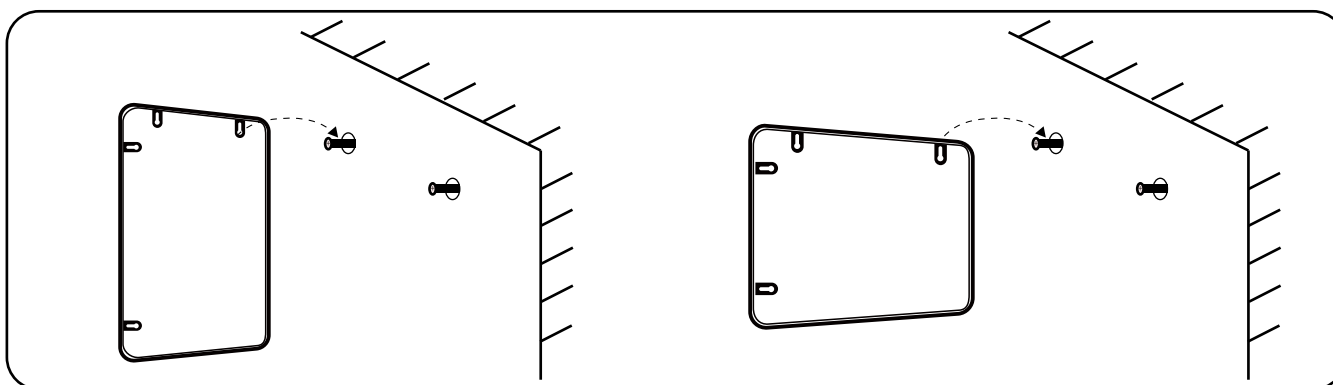

5. Appendere lo specchio alle viti.

## Manutenzione

Utilizzare un panno morbido e asciutto durante la pulizia. Non utilizzare detergenti o materiali abrasivi. Tenere l'umidità lontana dallo specchio.

**UK**

If you have any questions, please contact our customer care centre.

Our contact details are below:



0044-800-240-4004



enquiries@mhstar.co.uk

IMPORTER ADDRESS:

MH STAR UK LTD

Unit 27, Perivale Park,  
Horsenden lane South

Perivale, UB6 7RH

MADE IN CHINA

**ES**

Si tiene alguna pregunta, comuníquese con nuestro Centro de Atención al Cliente. Nuestros datos de contacto son los siguientes:



0034-931294512



atencioncliente@aosom.es

Importador/Fabricante/REP:

Spanish Aosom, S.L.

C/ Roc Gros, nº 15. 08550, Els Hostalets  
de Balenyà, Spain.

B66295775

atencioncliente@aosom.es

TEL: 931294512

HECHO EN CHINA

**FR**

Si vous avez la moindre question, veuillez contacter notre centre d'assistance à la clientèle.

Nos coordonnées sont les suivantes:



0033-1-84166106



aosom@mhfrance.fr

Importé par/Fabricant/REP:

MH France

2, rue Maurice Hartmann

92130 Issy-les-Moulineaux

France

Fabriqué en Chine

**PT**

Se tiver alguma dúvida, por favor contacte o nosso Centro de Atendimento ao Cliente. Os nossos dados de contacto são os seguintes:



0034-931294512



info@aosom.pt.

IMPORTADOR:

SPANISH AOSOM, S.L

C.ROC GROS N.15, 08550. ELS HOSTALETES DE BALENYÀ

TEL: 931294512 (SEG-SEX DAS 7:30H ÀS 16:30H)

INFO@AOSOM.PT

WWW.AOSOM.PT

**DE**

Wenn Sie Fragen haben, wenden Sie sich bitte an unser Kundendienstzentrum.

Unsere Kontaktdaten stehen unten:



0049-0(40)-88307530



service@aosom.de

Importeur/Hersteller/REP:

MH Handel GmbH

Wendenstraße 309

D-20537 Hamburg

Germany

IN CHINA HERGESTELLT

**IT**

In caso di dubbio, si prega di contattare il nostro centro assistenza clienti.

I nostri dettagli di contatto sono di seguito:



0039-0249471447



clienti@aosom.it

IMPORTATO DA/Produttore/REP:

AOSOM Italy srl

Centro Direzionale Milanofiori

Strada 1 Palazzo F1

20057 Assago (MI)

P.I.: 08567220960

FATTO IN CINA

