

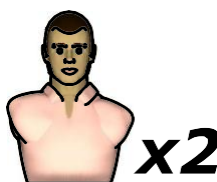
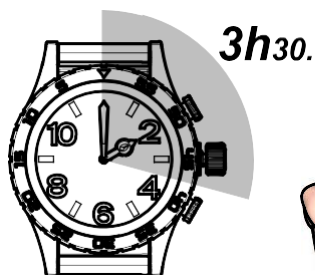
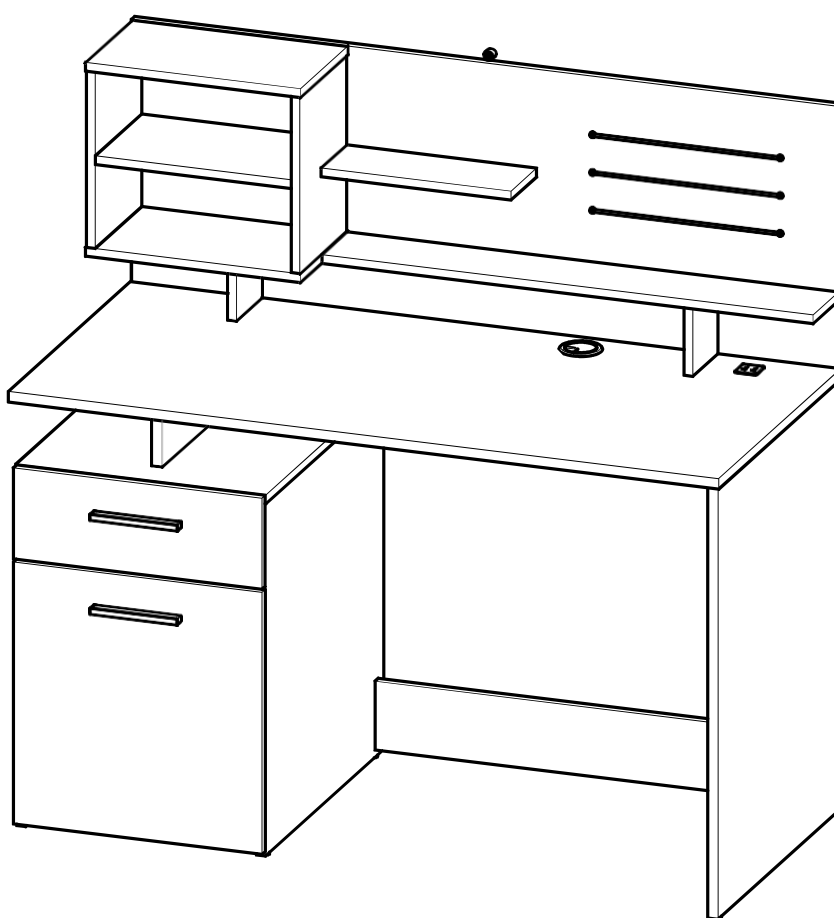

# Conforama

124622

- FR** NOTICE DE MONTAGE
- EN** ASSEMBLY INSTRUCTIONS
- DE** MONTAGEANLEITUNG
- ES** INSTRUCCIONES DE MONTAJE
- NL** MONTAGEVOORSCHRIFT
- IT** ISTRUZIONI DI MONTAGGIO
- PT** INSTRUÇÕES DE MONTAGEM
- CR** NAPUTCI ZA MONTAŽU
- HU** ÖSSZESZERELÉSI UTASÍTÁSOK

تعليمات التركيب (٤)



 Fabriqu  en France  
Made in France

C.B.A Meubles - 178-184 rue de la Pr v t   
59840 P renchies - FRANCE  
[contact@demeyere.fr](mailto:contact@demeyere.fr)

173573

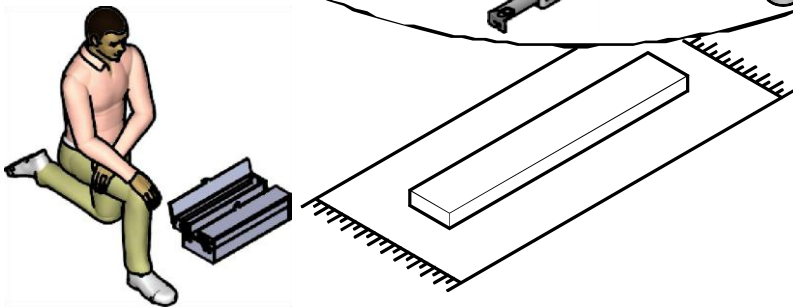
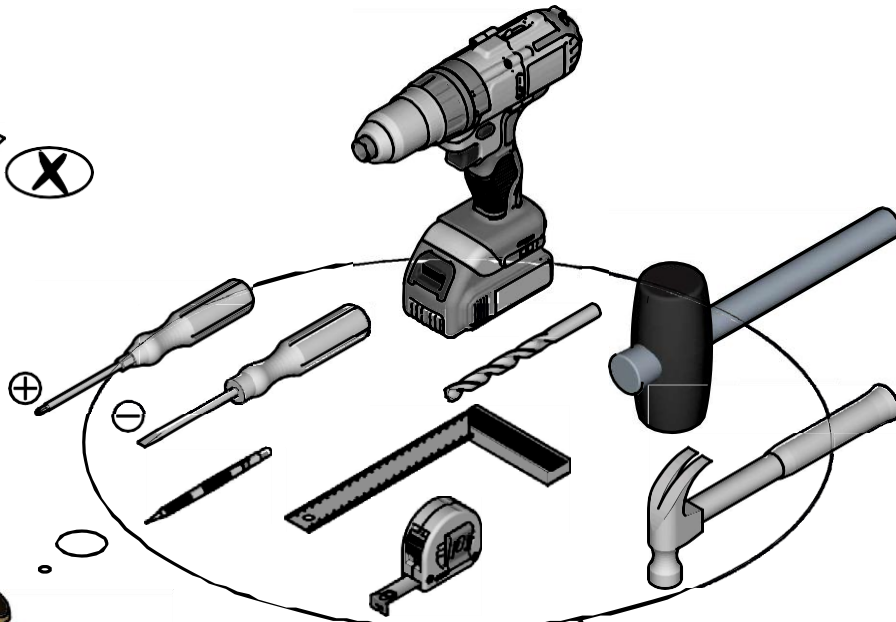
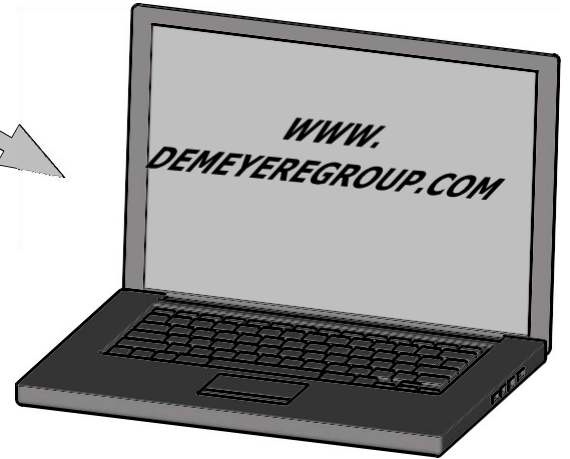
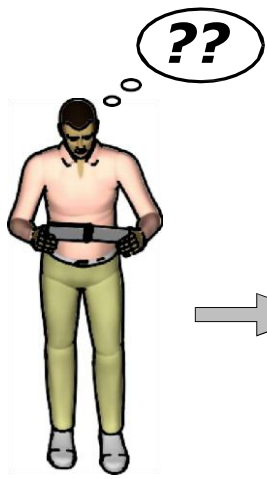

Donnez ou recyclez vos meubles.



Association

ou



Magasin

ou



Déchèterie

<https://quefairemesdechets.fr>

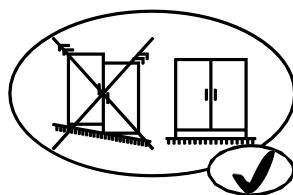
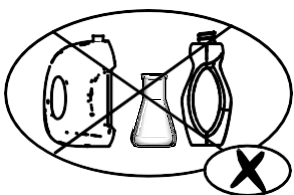

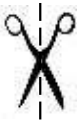

**Ai** x24

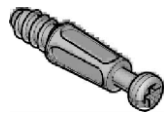

**L** x4

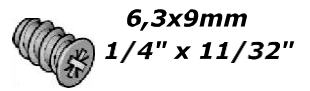

**Aj** x22



**M** x4

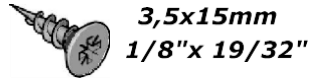

**C** x2



**N** x2

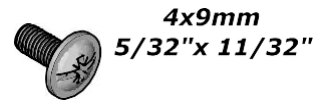

**D** x1

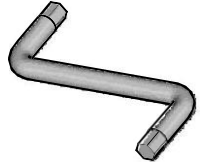

**O** x1

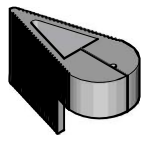

**E** x1

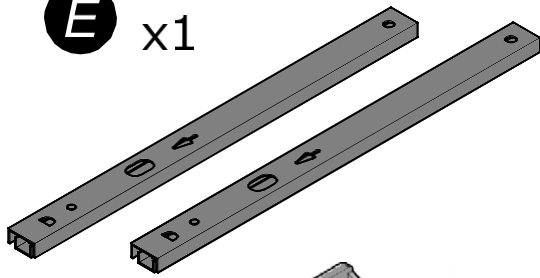

**P** x1

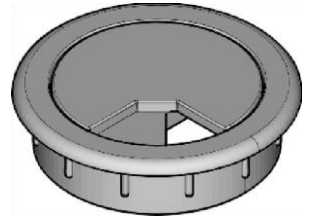

**F** x1

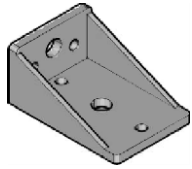

**Q** x1

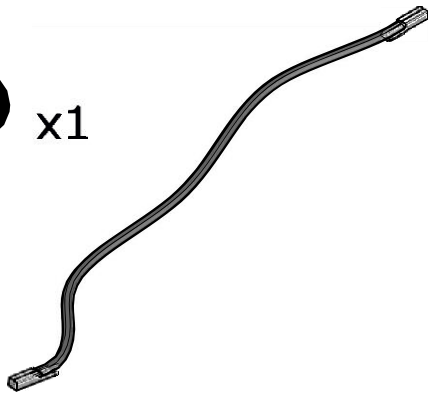

**G** x4

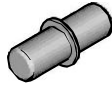

**R** x2

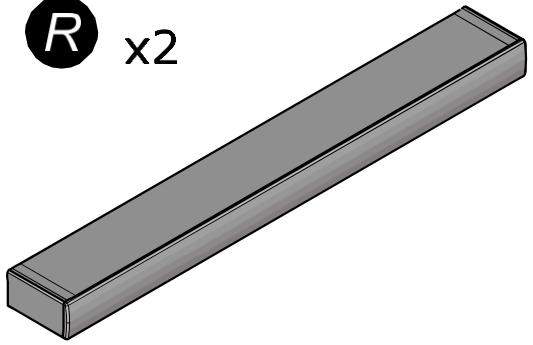

**H** x4



**I** x4

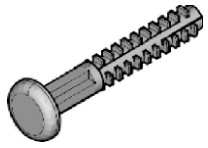

**J** x4

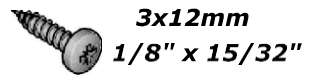

**K** x5

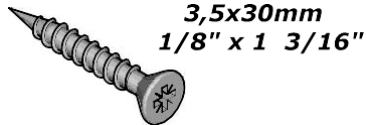

**S** x2

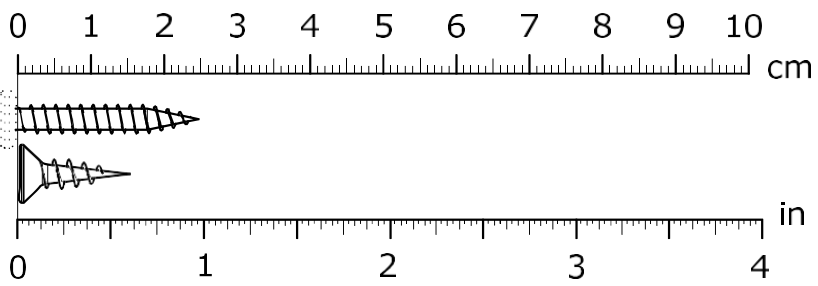
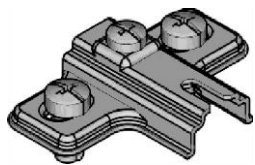

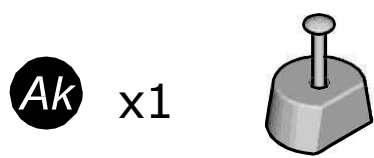
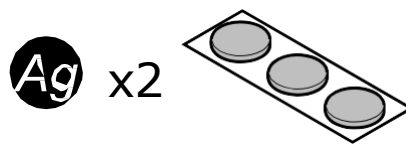
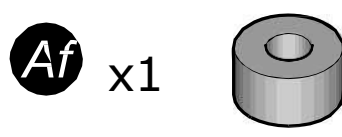
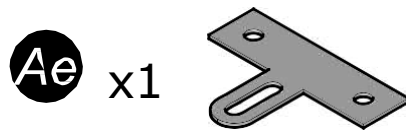
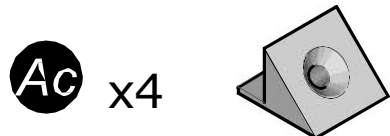
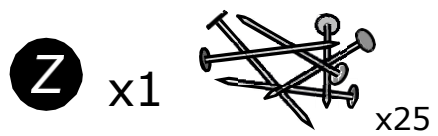
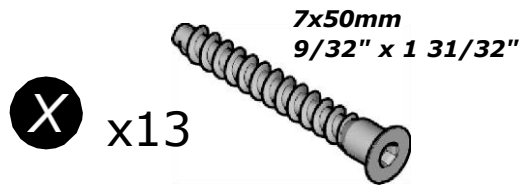
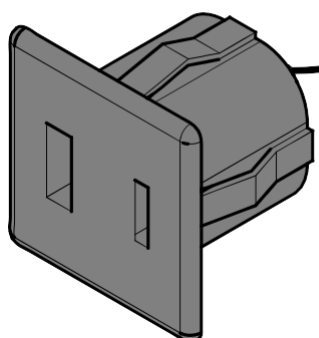
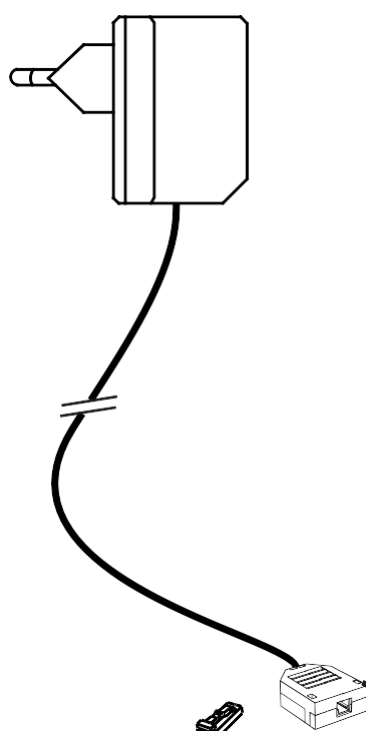
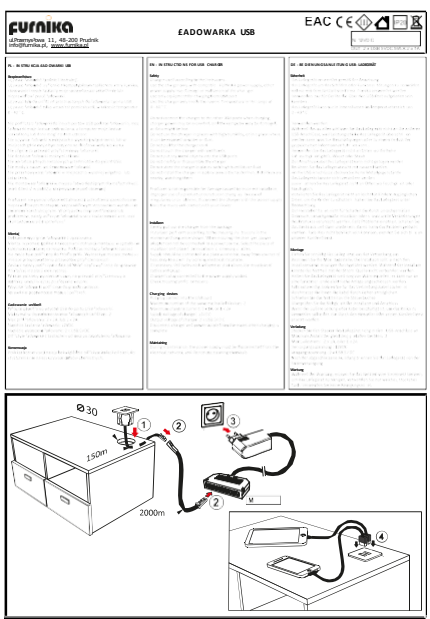
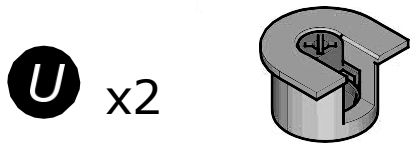
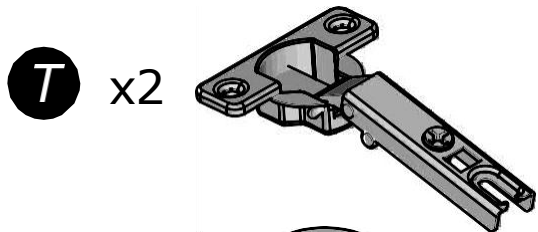

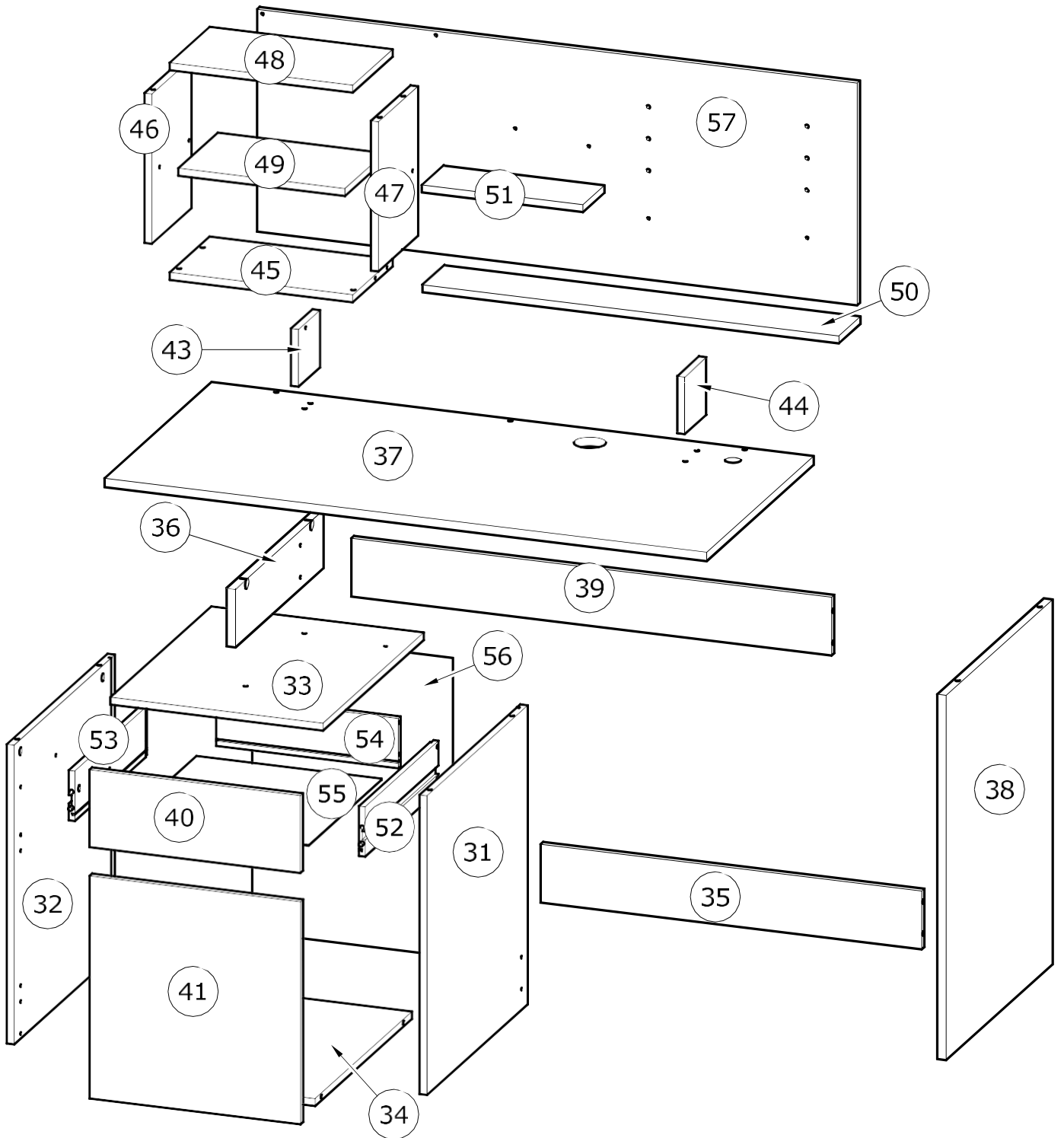

N°	MM		INCH		QTY
31	600	x 549	23 10/16	x 21 10/16	1
32	600	x 549	23 10/16	x 21 10/16	1
33	428	x 550	16 14/16	x 21 10/16	1
34	395	x 528	15 9/16	x 20 13/16	1
35	769	x 117	30 4/16	x 4 10/16	1
36	117	x 481	4 10/16	x 18 15/16	1
37	1 215	x 584	47 13/16	x 23	1
38	732	x 582	28 13/16	x 22 15/16	1
39	969	x 117	38 2/16	x 4 10/16	1
40	425	x 155	16 12/16	x 6 2/16	1
41	446	x 425	17 9/16	x 16 12/16	1
43	115	x 117	4 8/16	x 4 10/16	1
44	115	x 117	4 8/16	x 4 10/16	1

N°	MM		INCH		QTY
45	368	x 217	14 8/16	x 8 9/16	1
46	300	x 216	11 13/16	x 8 8/16	1
47	300	x 216	11 13/16	x 8 8/16	1
48	368	x 217	14 8/16	x 8 9/16	1
49	335	x 215	13 3/16	x 8 7/16	1
50	840	x 118	33 1/16	x 4 10/16	1
51	325	x 118	12 13/16	x 4 10/16	1
52	400	x 100	15 12/16	x 3 15/16	1
53	400	x 100	15 12/16	x 3 15/16	1
54	367	x 100	14 7/16	x 3 15/16	1
55	373	x 398	14 11/16	x 15 11/16	1
56	599	x 404	23 9/16	x 15 14/16	1
57	1 211	x 446	47 11/16	x 17 9/16	1

FR

**AVERTISSEMENT : MEUBLE A FIXER IMPERATIVEMENT AU MUR AFIN D'EVITER SON BASCULEMENT**

- Pour installer correctement ce produit et éliminer les risques pour votre sécurité, merci de suivre exactement ce manuel d'instruction.
- Fixer le meuble au mur avec les attaches prévues à cet effet
- Les vis et les chevilles ne sont pas fournies. Utiliser des vis et des chevilles adaptées au support.

EN

**WARNING: FURNITURE TO BE ATTACHED TO THE WALL TO PREVENT OVERTURNING**

- Installation shall be carried out exactly according to those instructions-otherwise a safety risk can occur if incorrectly installed;
- Attach the furniture to the wall with the fastening provided for this purpose
- Screw and Pegs are not supplied. Use Screws and pegs adapted to the support.

DE

**WARNUNG: DAS MÖBEL MUSS AN DER WAND BEFESTIGT WERDEN, UM ZU VERHINDEN DASS ES KIPPT**

- Um das Produkt korrekt zu installieren und um Risiken für Ihre Sicherheit zu verhindern, die Gebrauchsanleitung genauestens befolgen.
- Das Möbel mit den vorgesehenen Befestigungen an einer Wand befestigen.
- Schrauben und Dübel sind nicht im Lieferumfang enthalten. Passende Schrauben und Dübel verwenden.

ES

**ADVERTENCIA: ESTE MUEBLE DEBE ESTAR SIEMPRE FIJO EN LA PARED PARA EVITAR QUE VUELQUE**

- Para instalar correctamente este producto y eliminar los riesgos para la seguridad, seguir exactamente las instrucciones del manual.
- Fijar el mueble a la pared con las sujeciones previstas a este efecto.
- Los tornillos y los tacos no están incluidos. Utilizar tornillos y tacos adaptados al soporte.

NL

**WAARSCHUWING: MEUBEL MOET VERPLICHT AAN DE MUUR BEVESTIGD WORDEN ZODAT HET NIET KAN OMVALLEN**

- Om dit product correct te installeren en alle risico's voor uw veiligheid te elimineren, gelieve de instructies in deze handleiding nauwgezet op te volgen.
- Zet het meubel vast aan de muur met de hiertoe voorziene bevestigingen.
- De schroeven en pluggen zijn niet meegeleverd. Gebruik schroeven en pluggen die geschikt zijn voor het materiaal van de muur.

IT

**AVVERTENZA: MOBILE DA FISSARE IMPERATIVAMENTE AL MURO PER EVITARE CHE SI RIBALTI**

- Per installare correttamente questo prodotto ed eliminare i rischi per la vostra sicurezza, si prega di seguire esattamente il manuale d'istruzioni.
- Fissare il mobile al muro con gli appositi ganci.
- Le viti e i tasselli non sono forniti. Utilizzare viti e tasselli adatti al supporto.

PT

**ADVERTÊNCIA: MÓVEL A FIXAR OBRIGATORIAMENTE À PAREDE PARA EVITAR A SUA QUEDA**

- Para instalar corretamente este produto e eliminar os riscos para a sua segurança, é favor seguir exatamente este manual de instruções.
- Fixe o móvel à parede com as fixações previstas para o efeito
- Os parafusos e as cavilhas não são fornecidos. Utilize parafusos e cavilhas adaptados ao suporte.

CR

**UPOZORENJE : UČVRSTITE ORMARIĆ NA ZID KAKO BISTE SPRIJEČILI NJEGOVO LJULJANJE**

- Kako biste pravilno postavili ovaj proizvod i uklonili sigurnosne rizike kojima se izlažete, pridržavajte se strogo ovog priručnika s uputama.
- Postavite ormarić na zid pripadajućim sponama. Vijci i svornjci ne isporučuju se. Upotrijebite nosne vijke i svornjke.

Hu

**FIGYELEM: A BÚTORT FELTÉTENÜL RÖGZÍTENI KELL A FALHOZ, HOGY ELKERÜLJE A FELBILLENÉSÉT**

- A termék megfelelő elhelyezéséhez és a biztonságot érintő kockázatok kiküszöböléséhez pontosan kövesse ezt a használati útmutatót.
- Rögzítse a bútort a falhoz az erre a célra szolgáló rögzítőelemekkel.
- A csavarok és a tiplik nincsenek mellékelve. Használjon a tartóhoz illő csavarokat és tipliket.

العربية:

**تحذير: قطعة أثاث يلزم تثبيتها على الحائط لتجنب تأرجحها**

- لتركيب هذا المنتج بشكل صحيح وتجنب المخاطر من أجل سلامتك، يرجى اتباع كتيب التعليمات هذا بالضبط.
- تثبت قطعة الأثاث على الحائط بواسطة العلاقات المخصصة لهذا الغرض
- إن البراغي والخوابير غير متوفرة مع المنتج. تستخدم براغي وخوابير ملائمة للحائط الذي يتم التثبيت عليه.

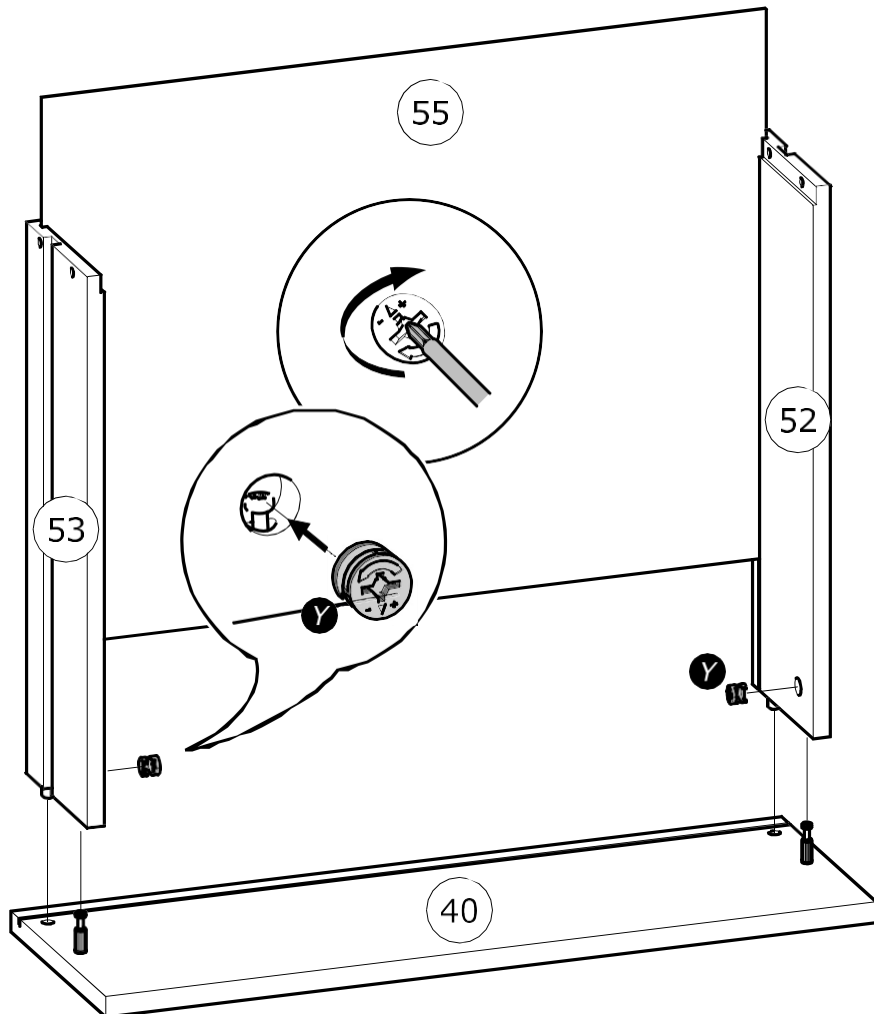
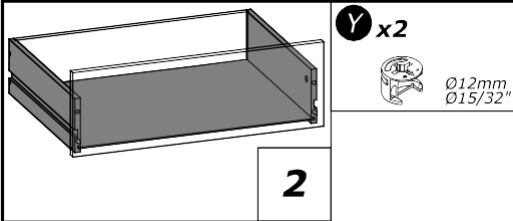
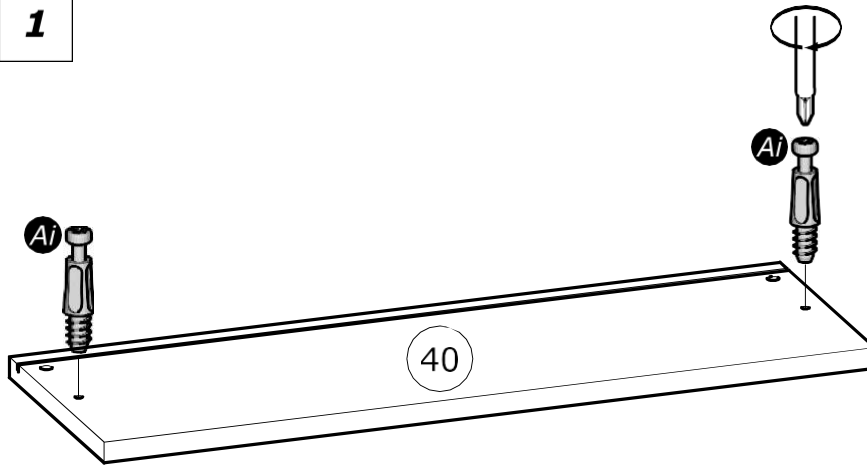
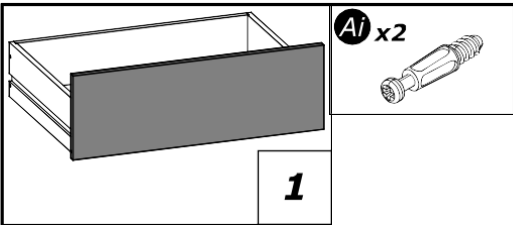

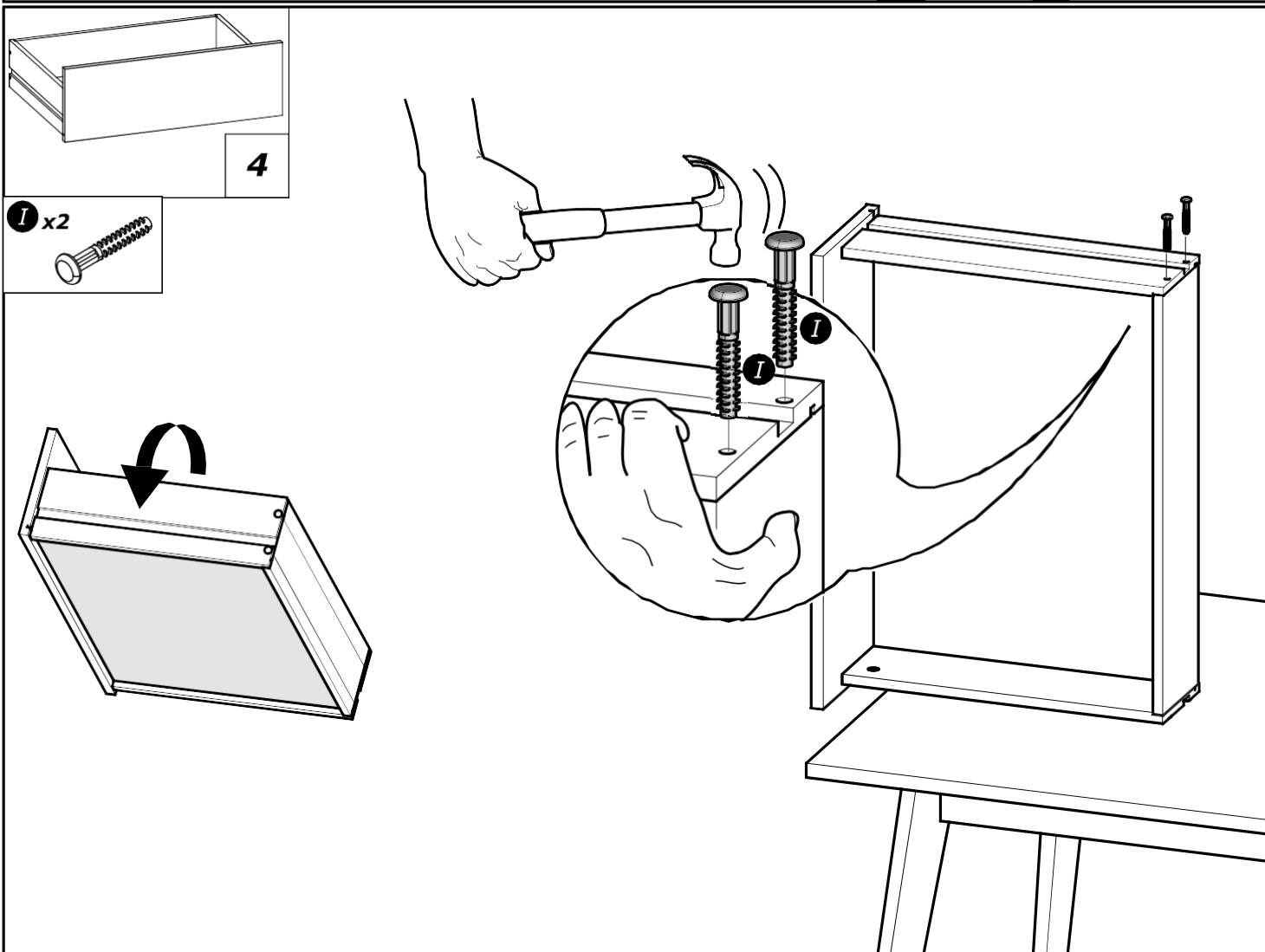
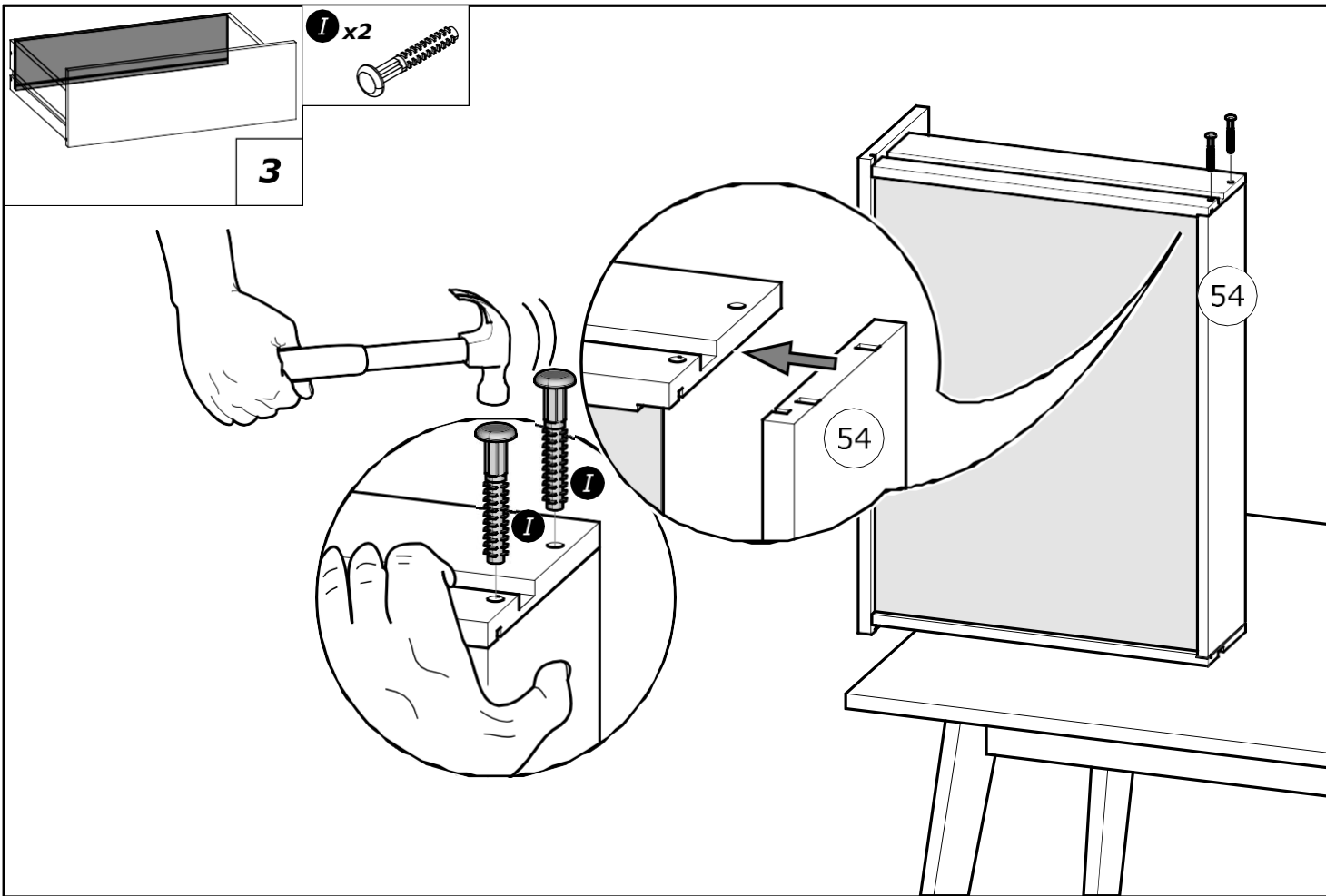

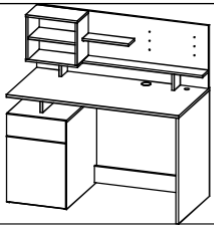

5

R x1

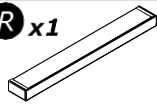

A1 x2

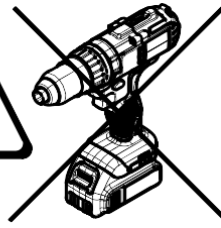
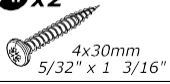

[www.Demeyere.fr](http://www.Demeyere.fr)

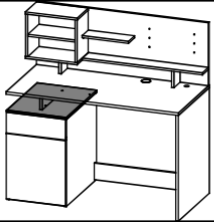
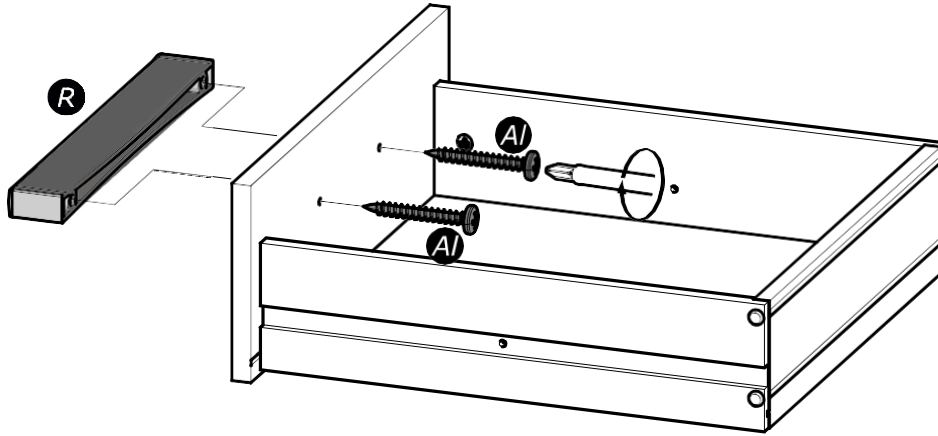

6

A1 x4

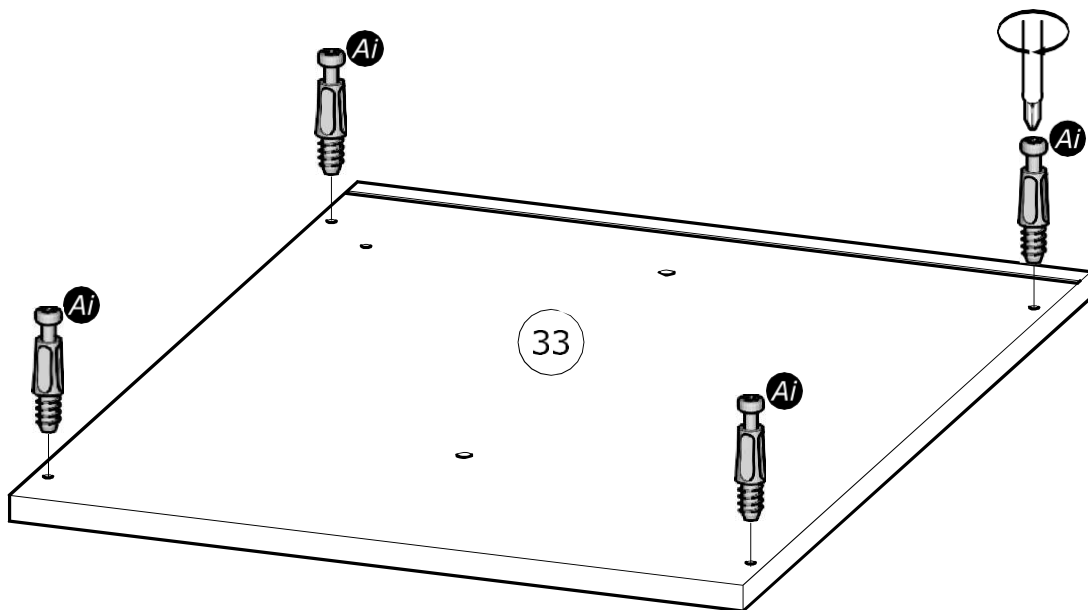
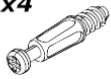

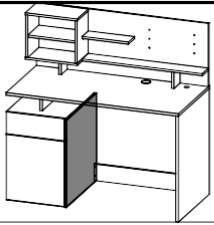

7

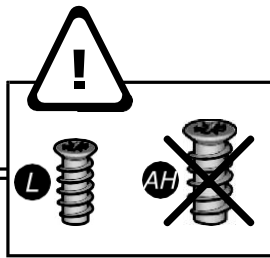
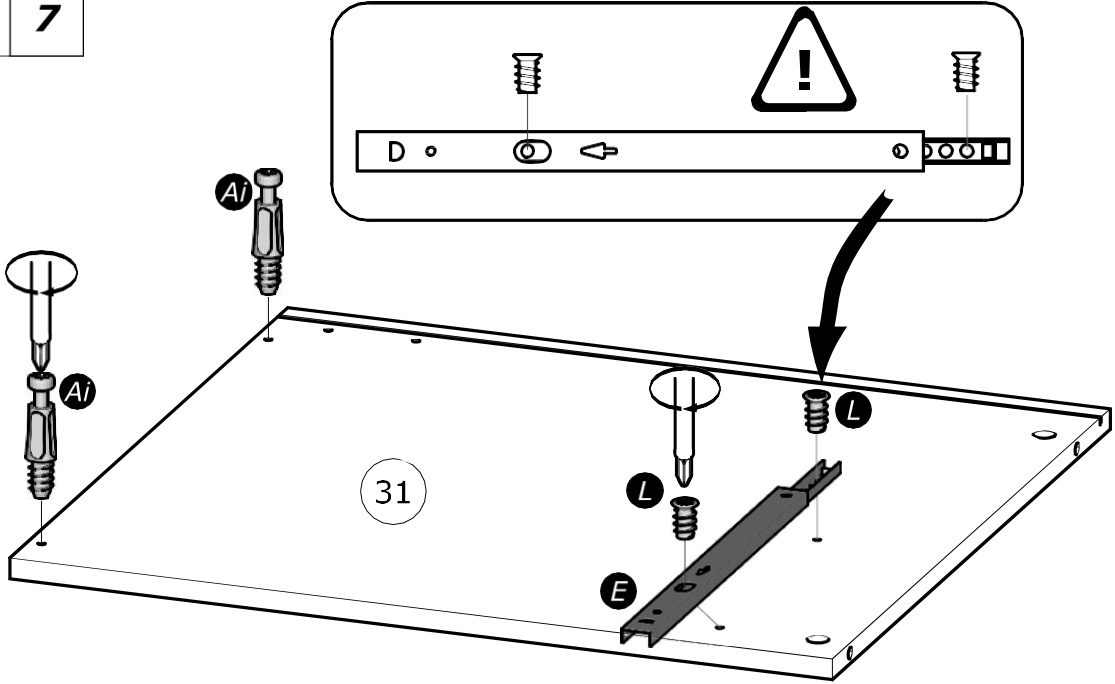
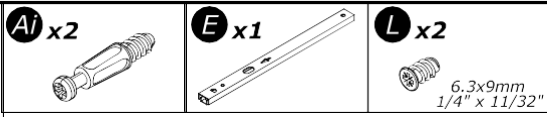

www.Demeyere.fr

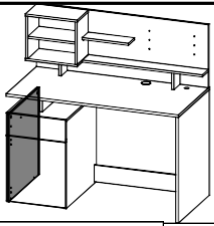

8

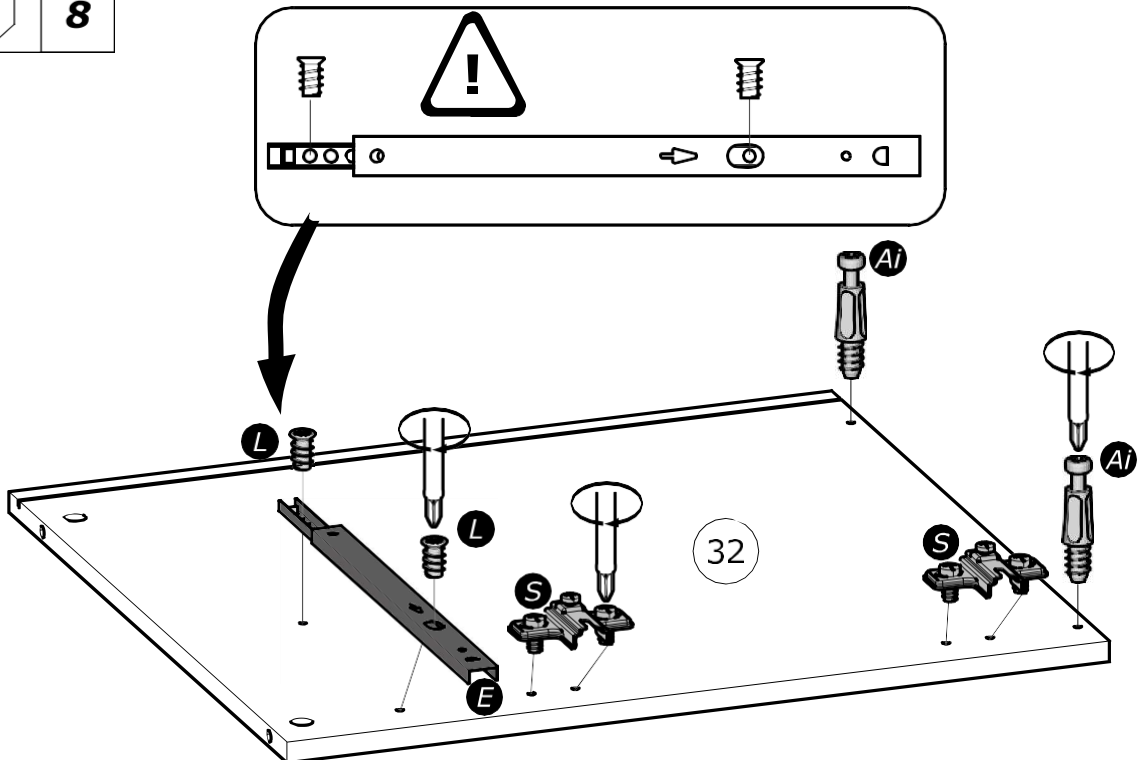
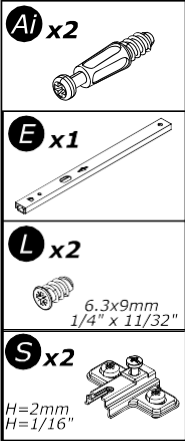

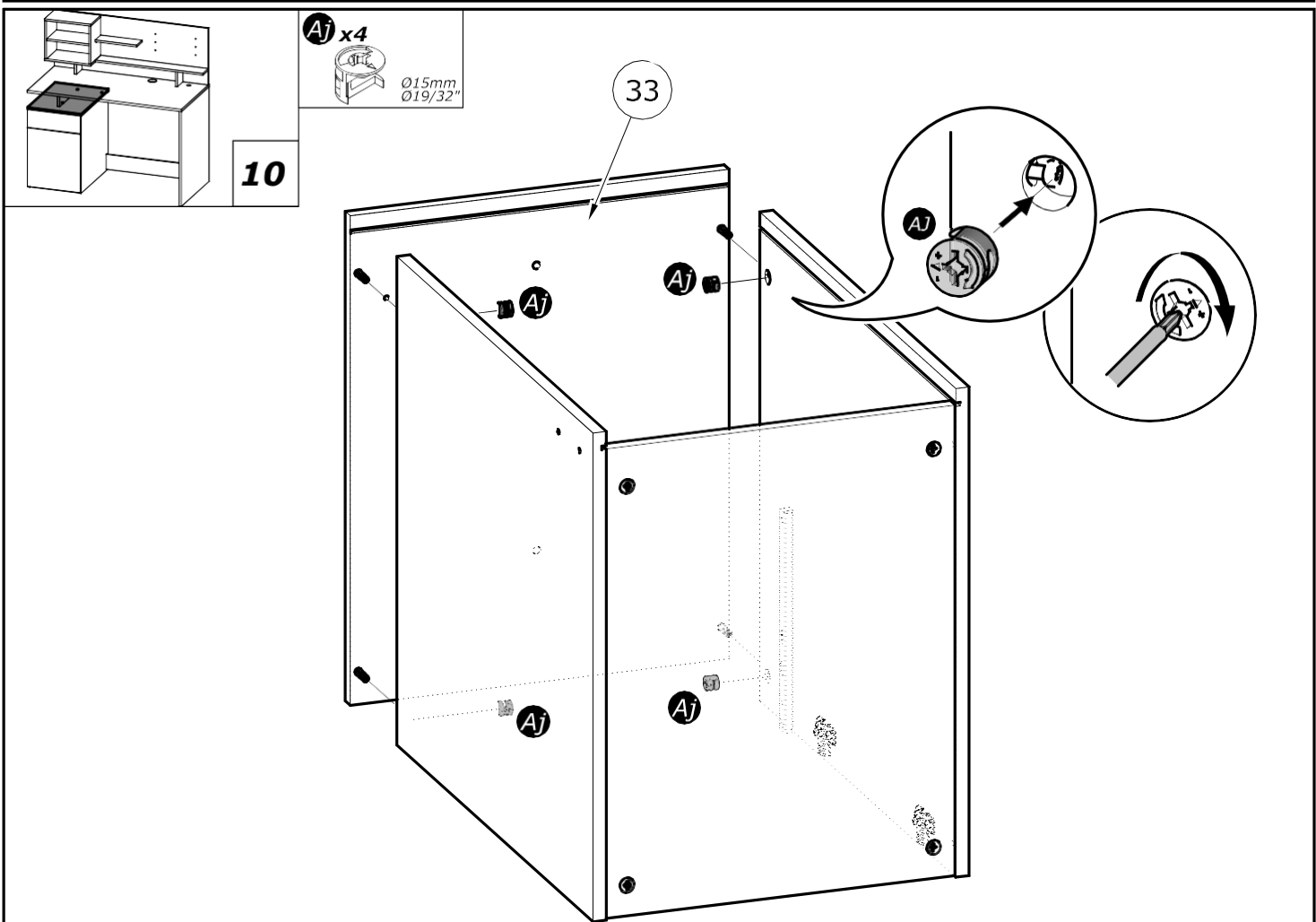
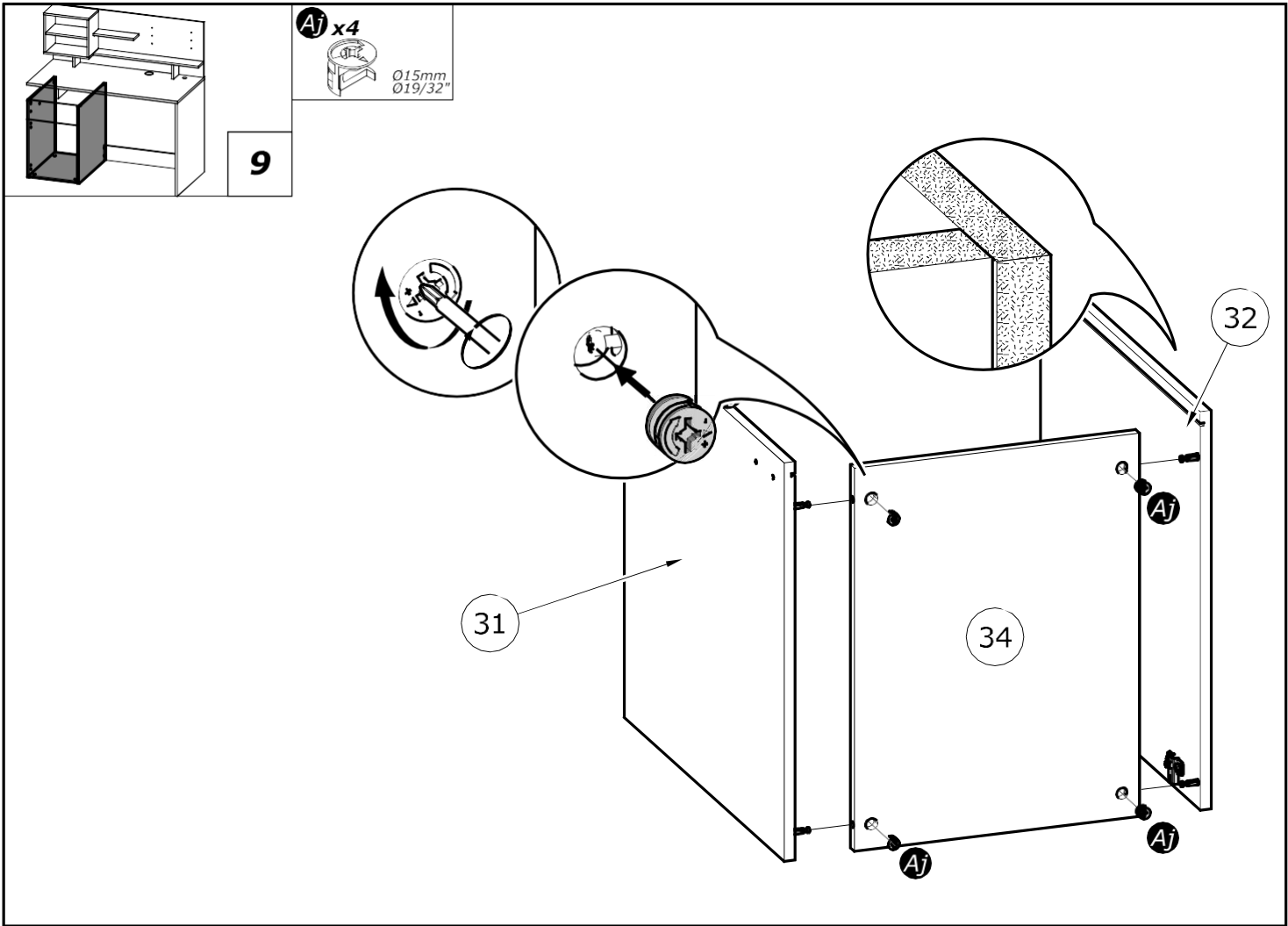

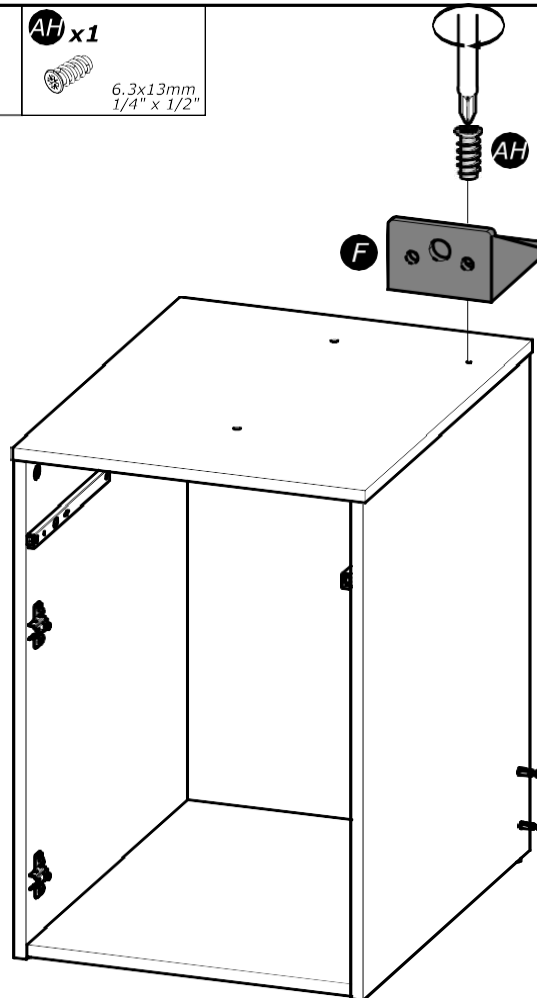
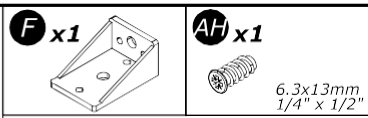
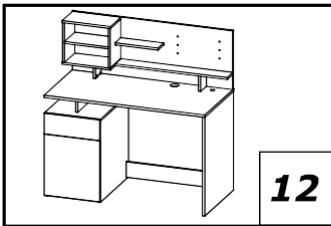
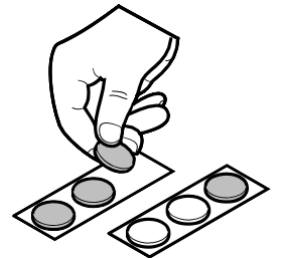
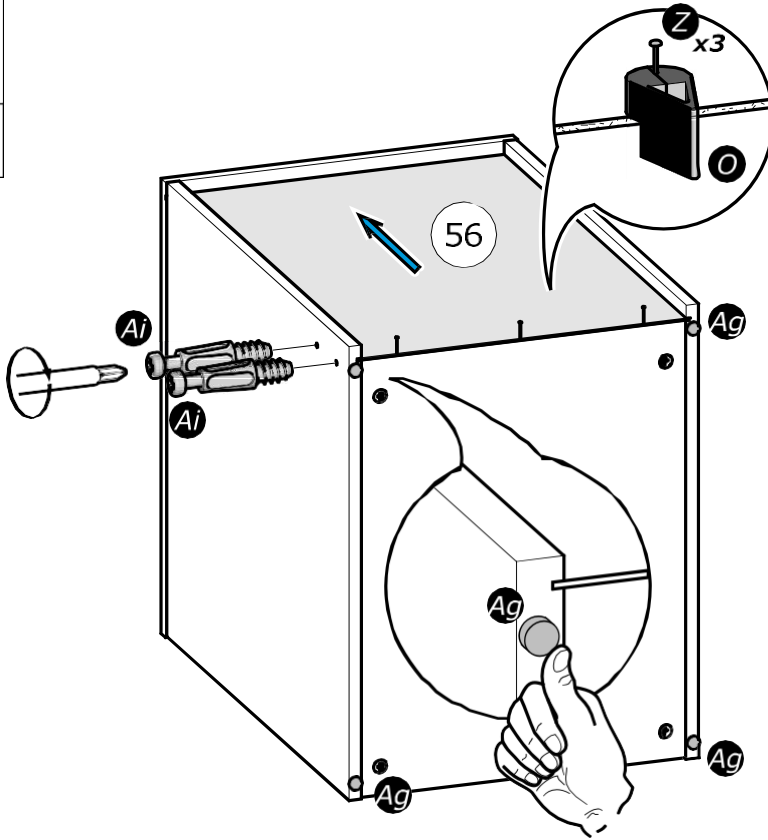
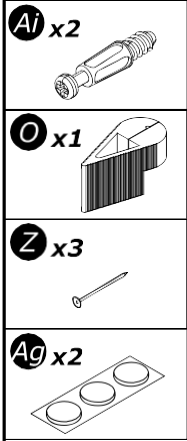
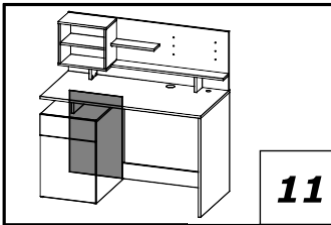

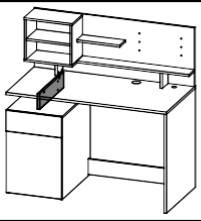

13

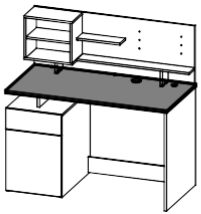
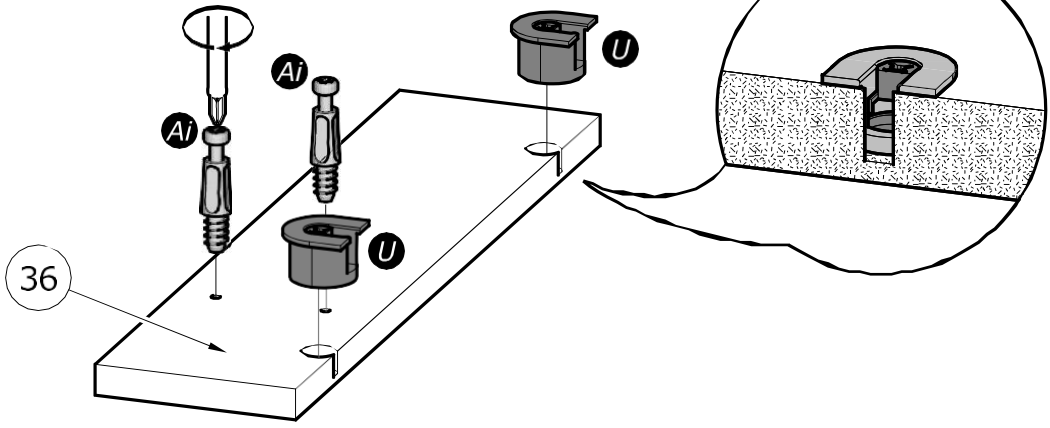
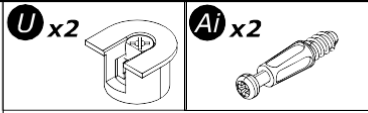

14

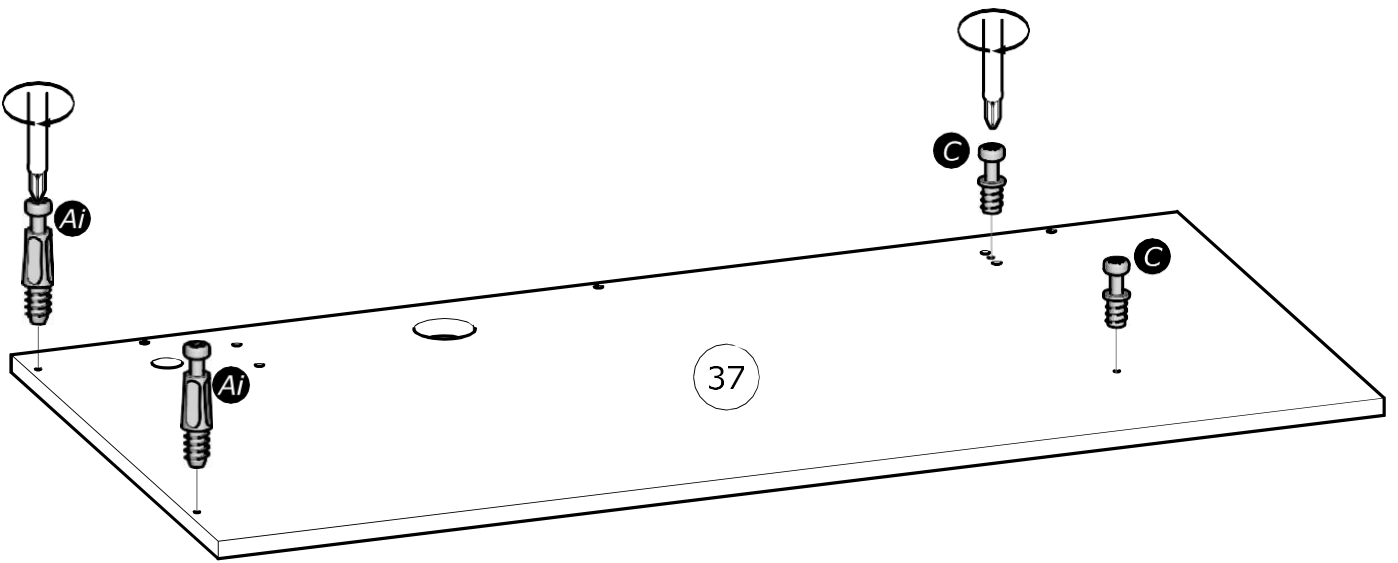
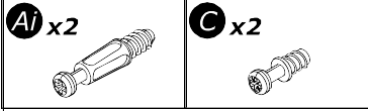

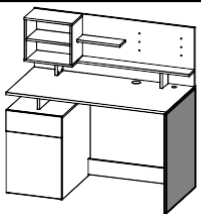

15

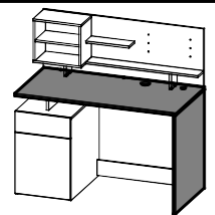
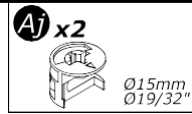
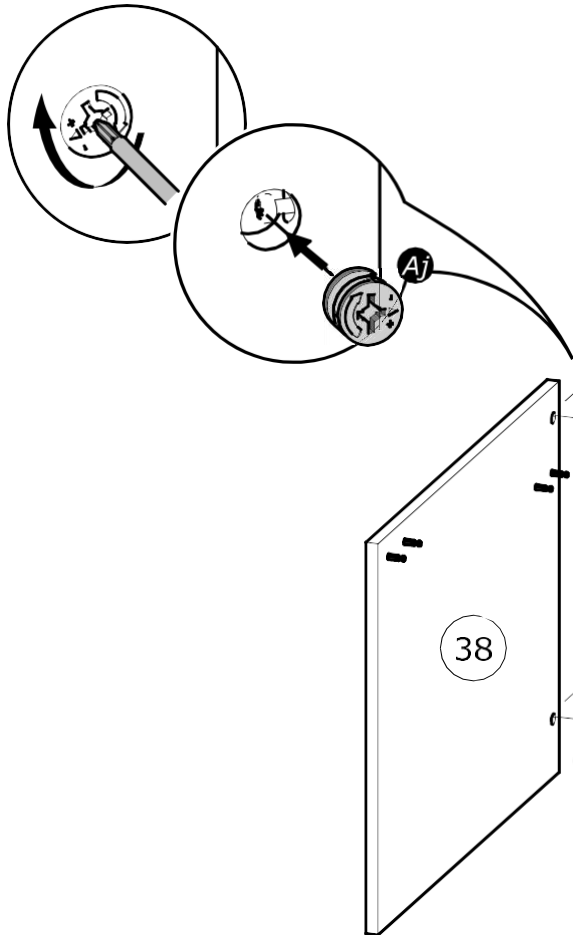
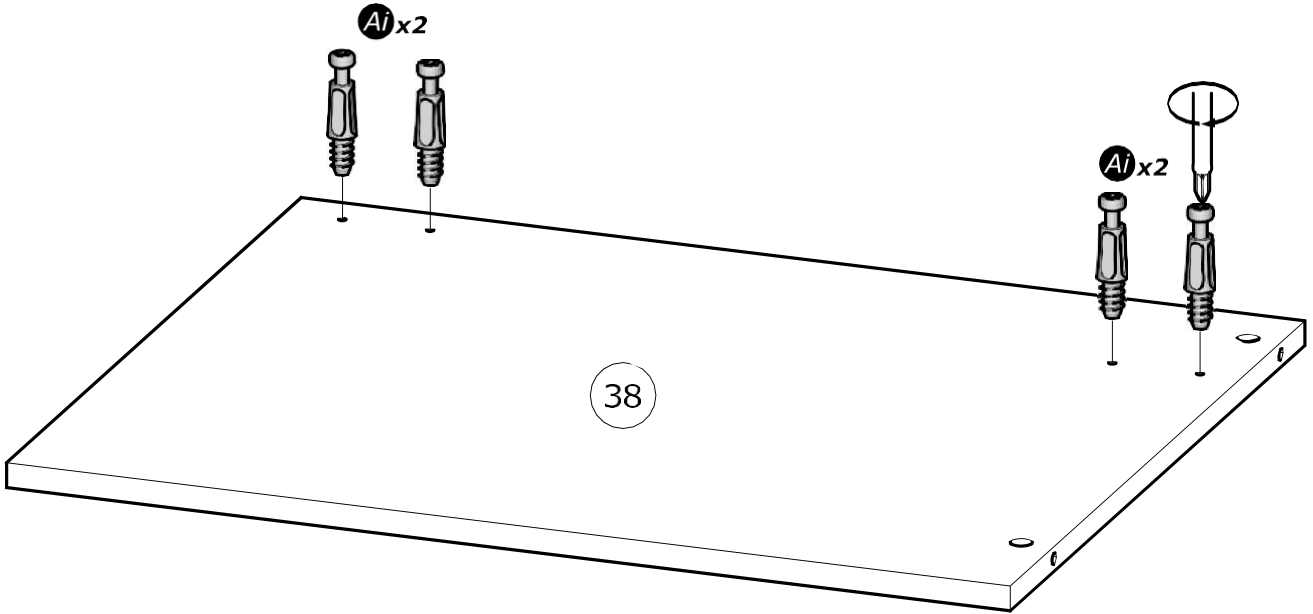
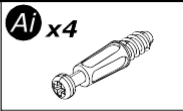

16

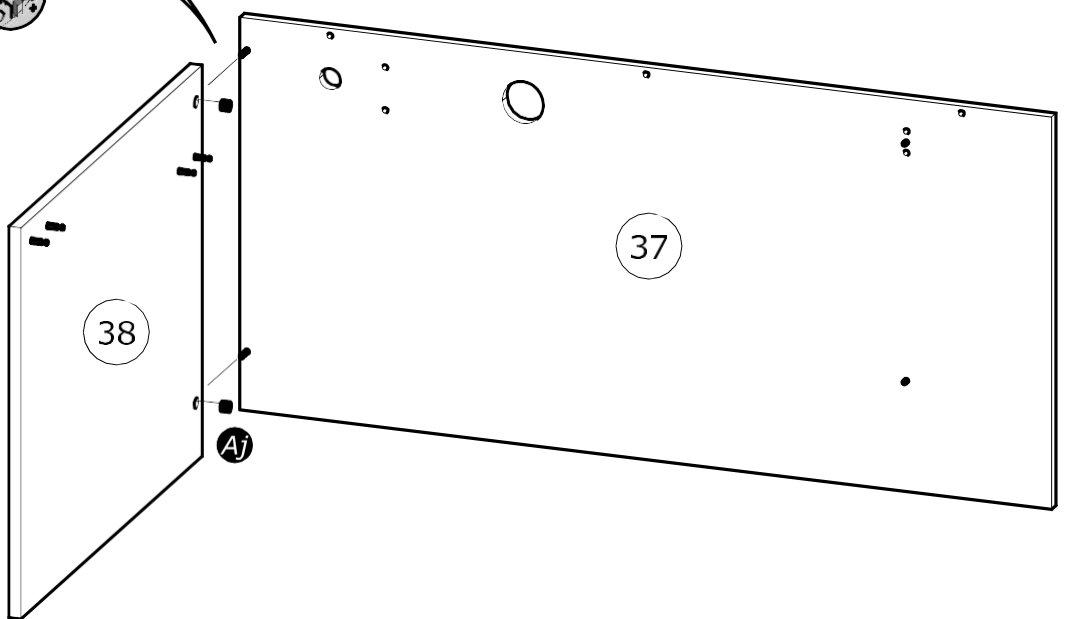

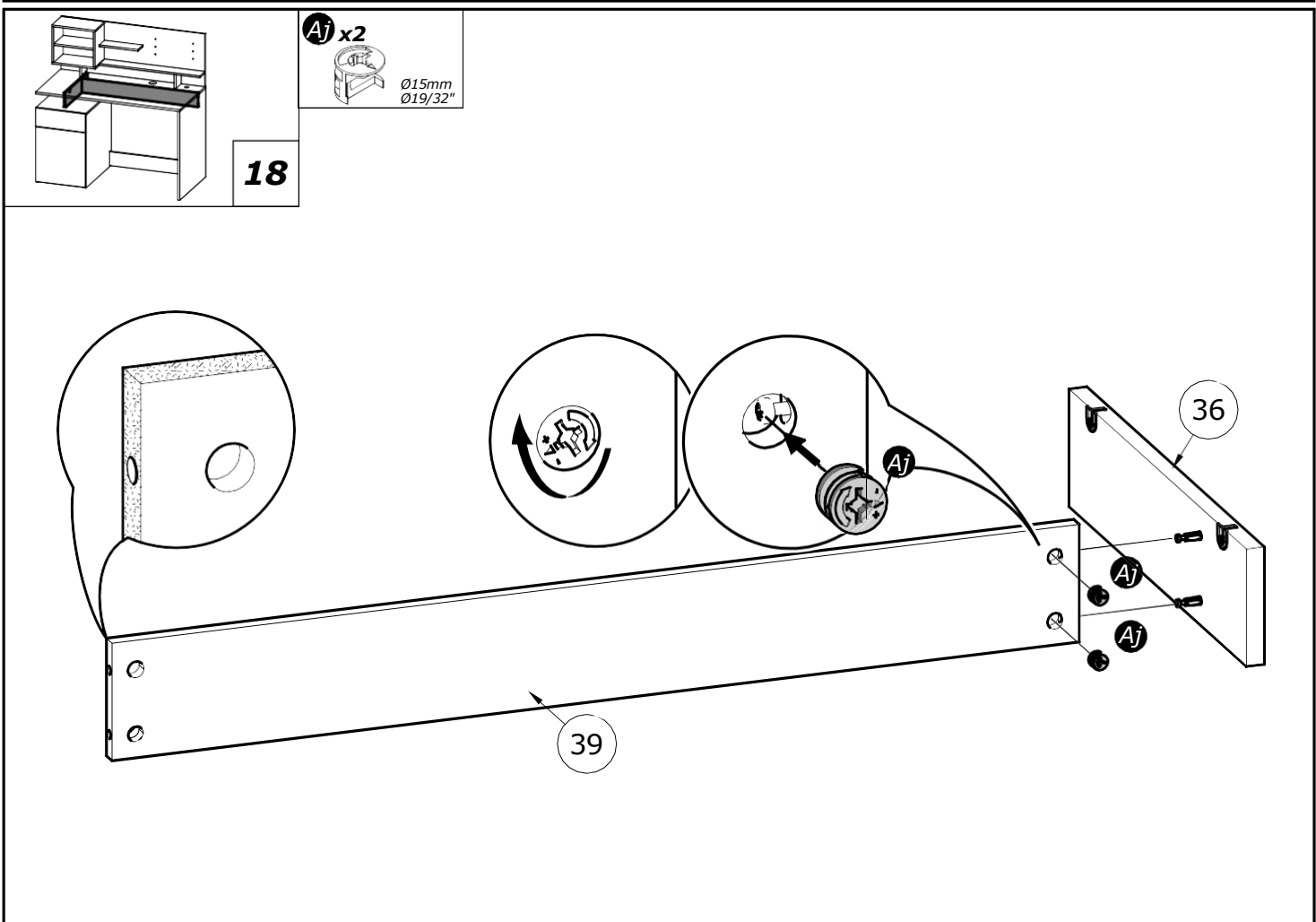
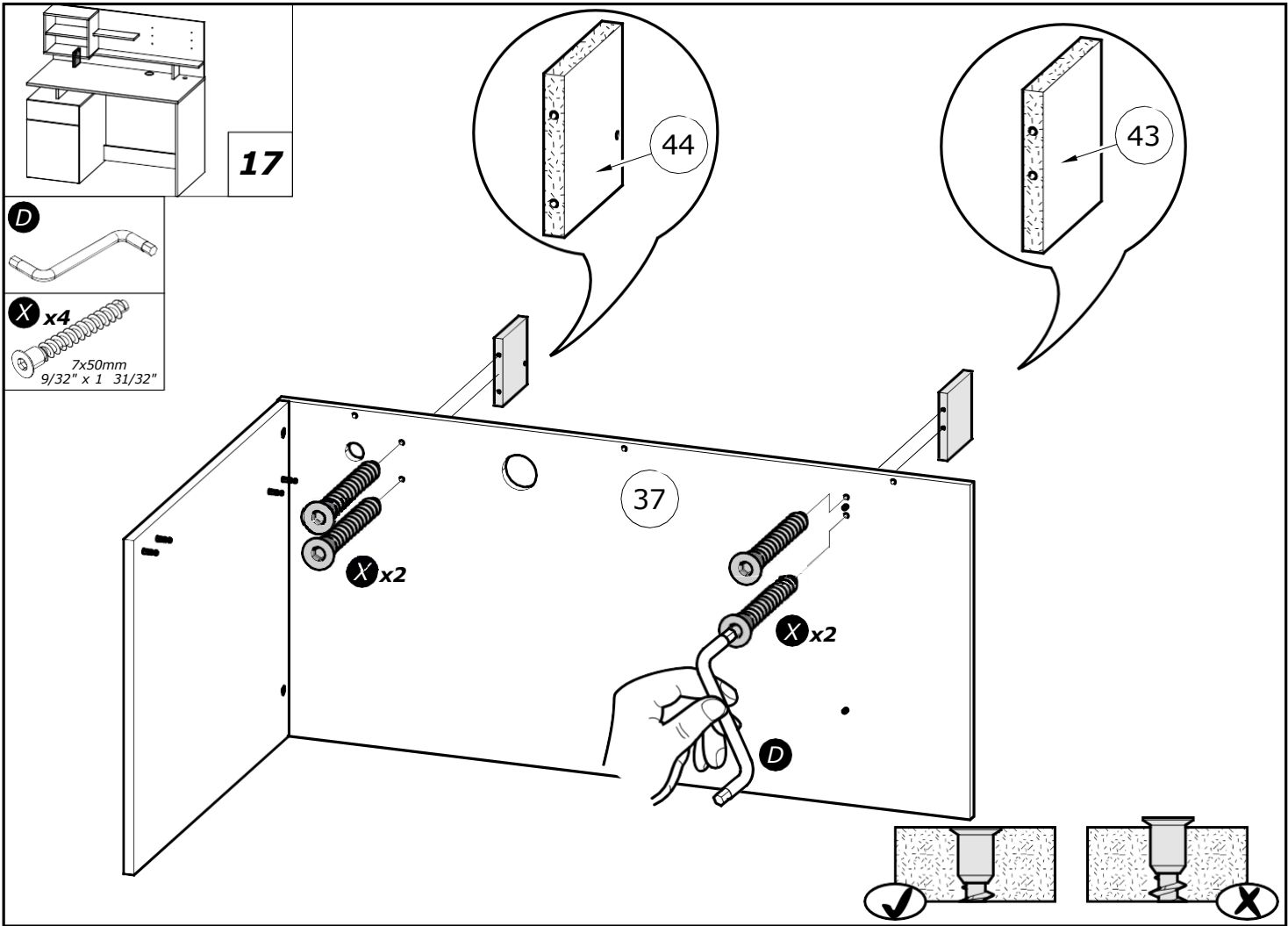

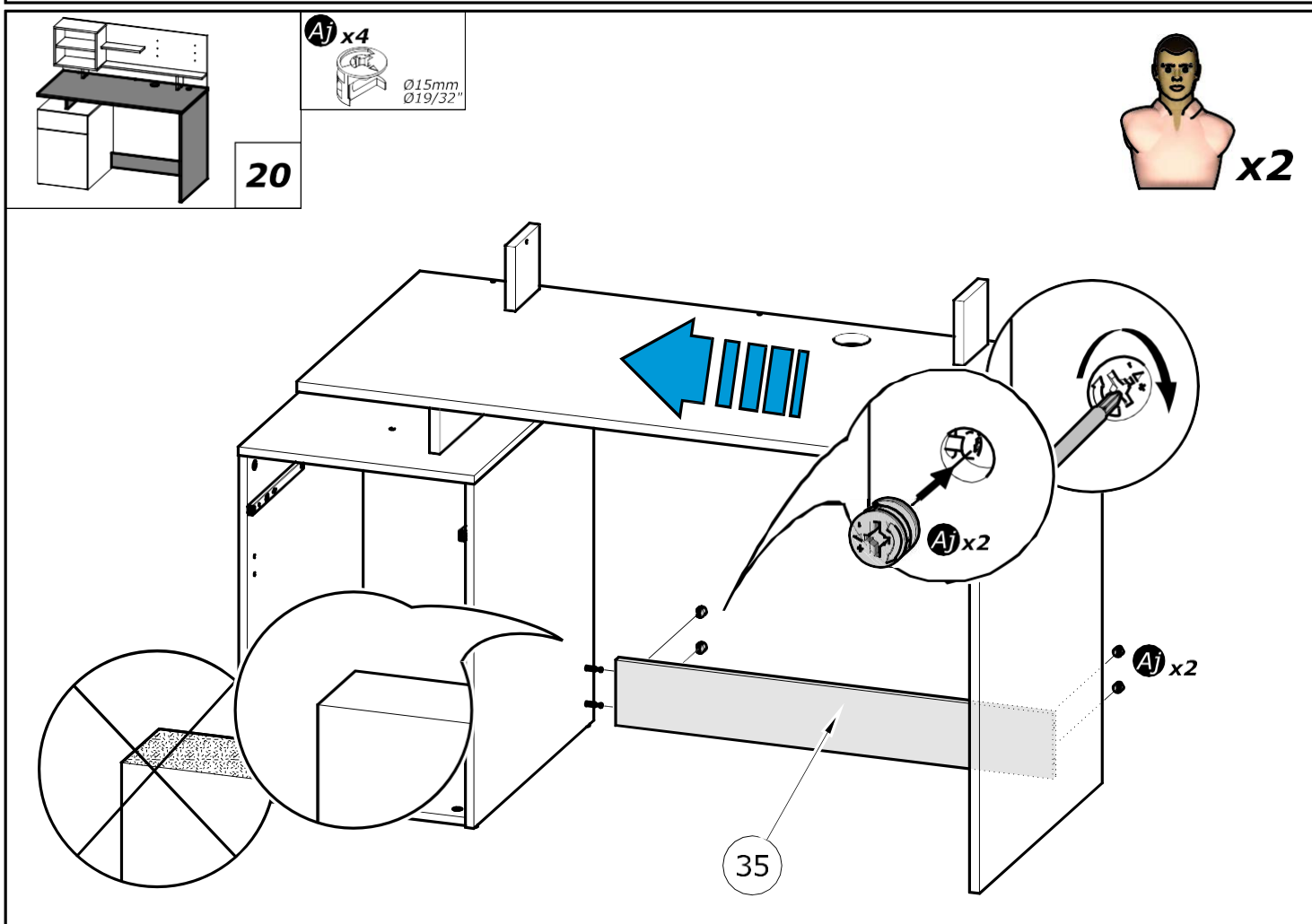
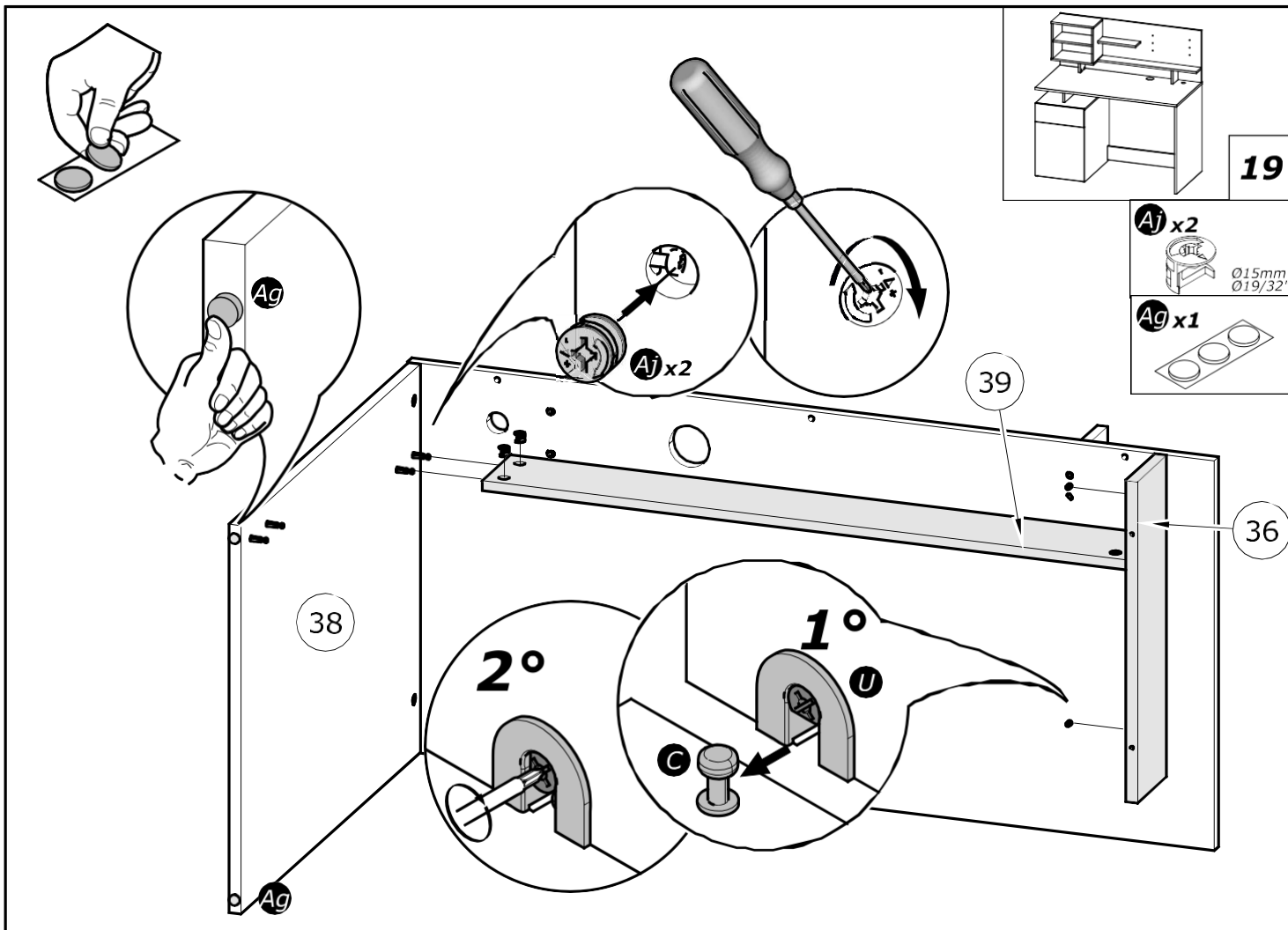

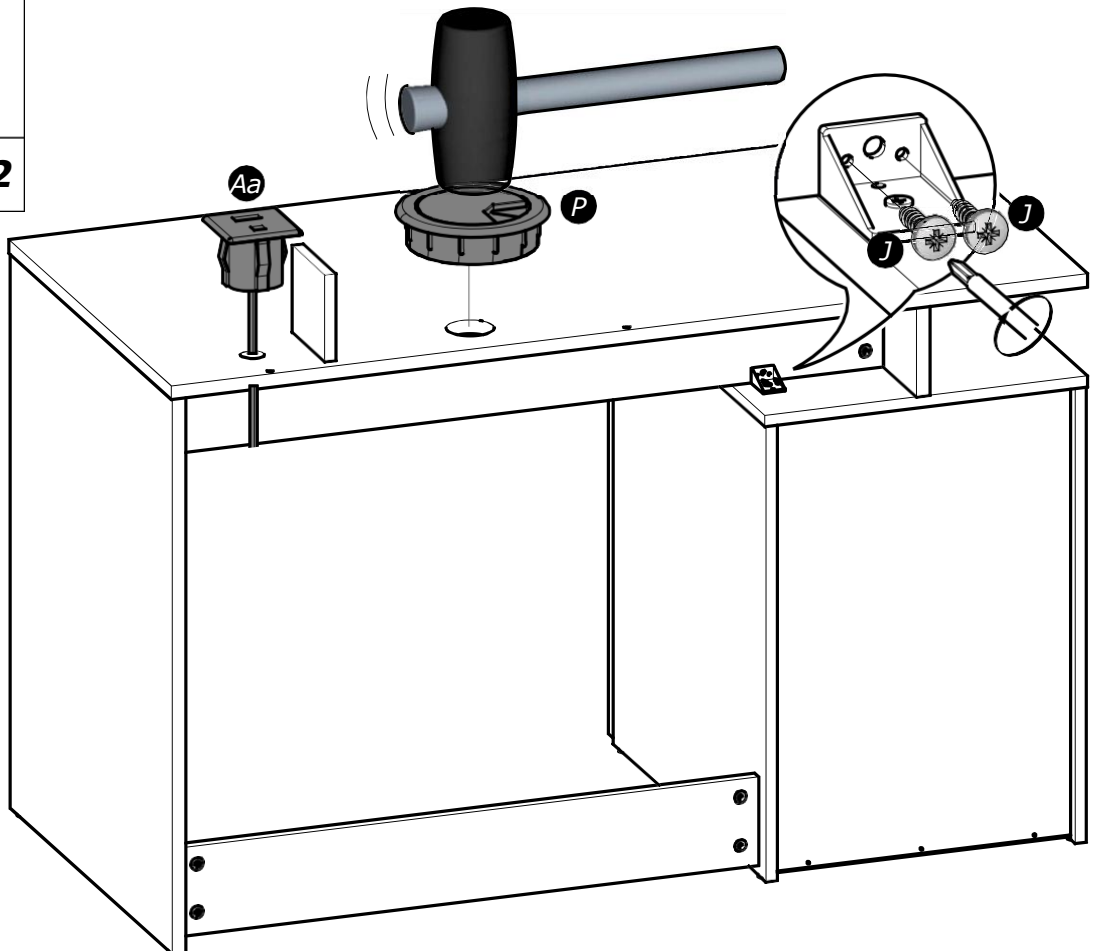
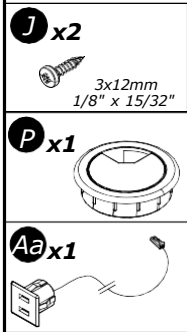
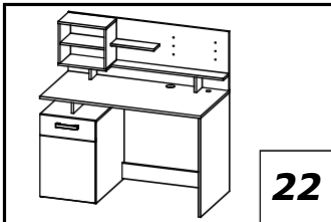
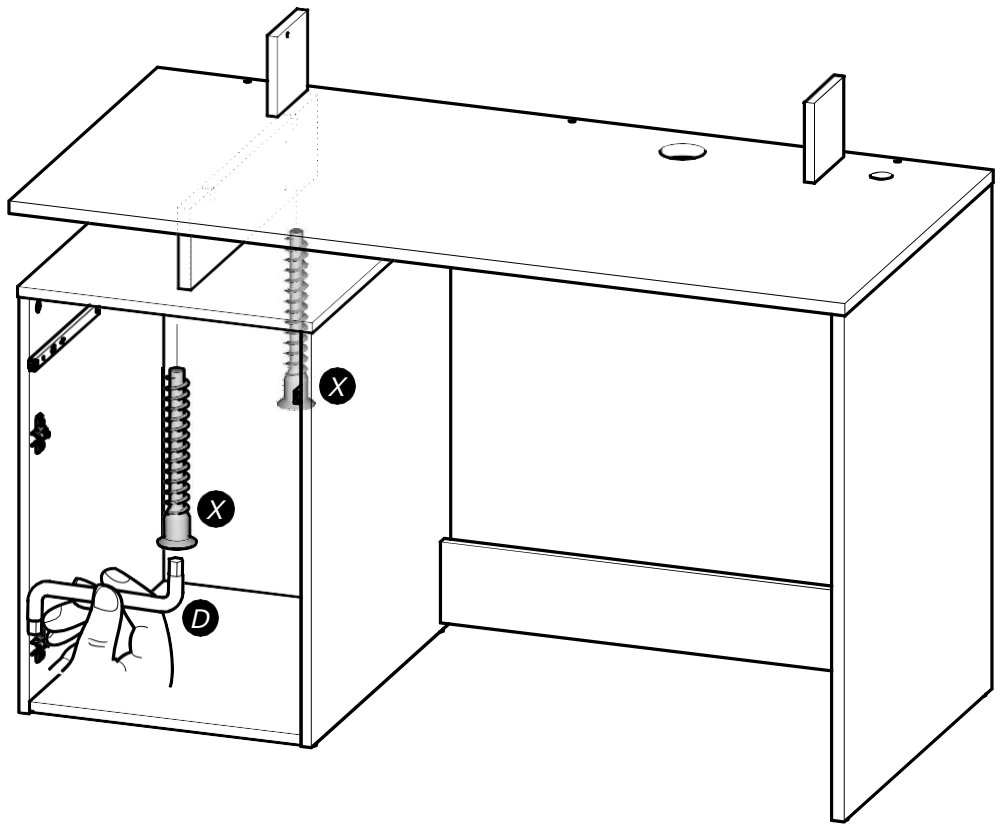
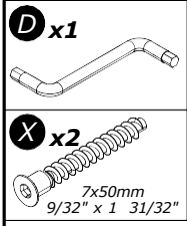
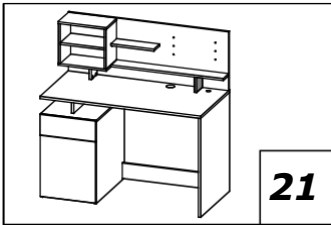

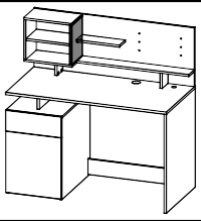

23

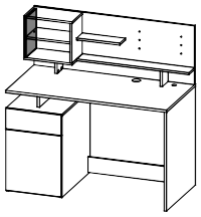
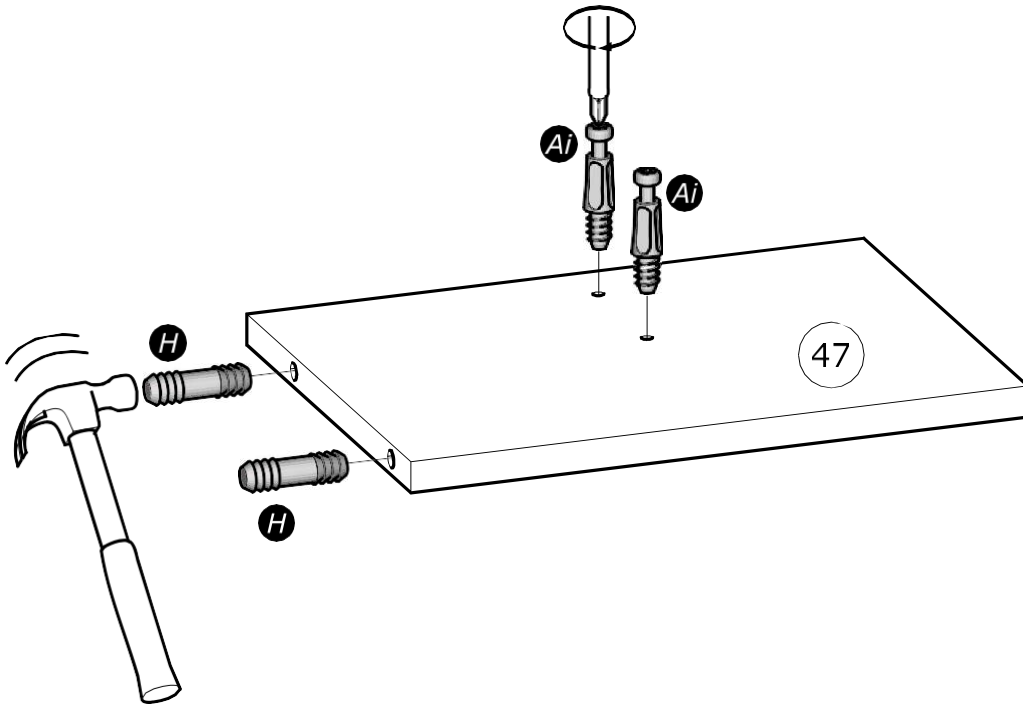
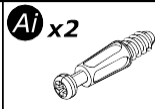

24

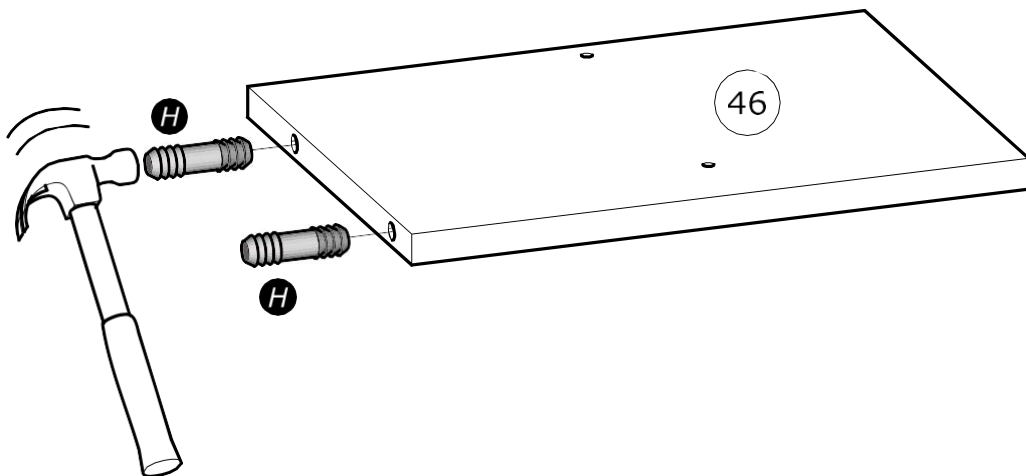
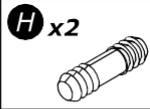

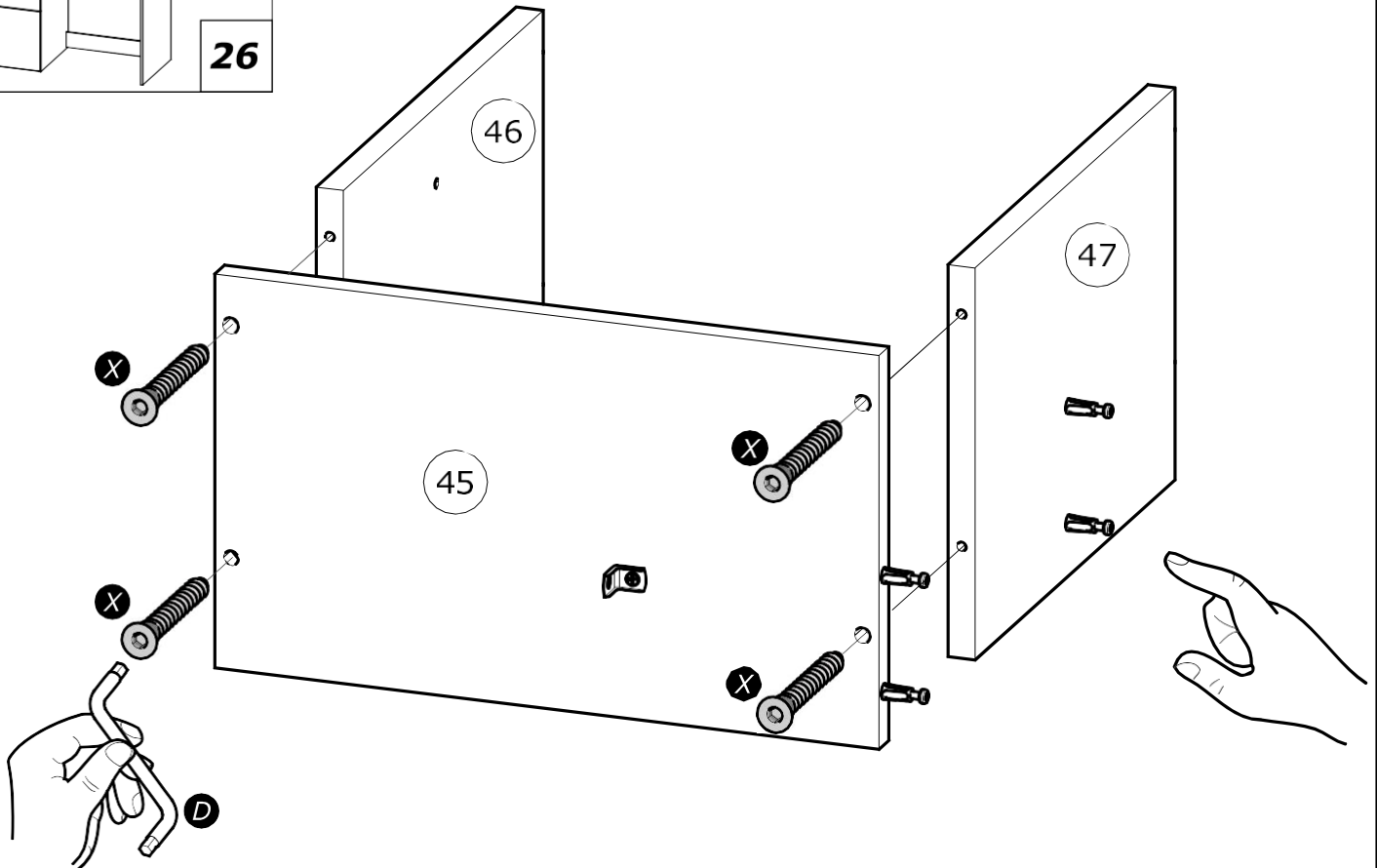
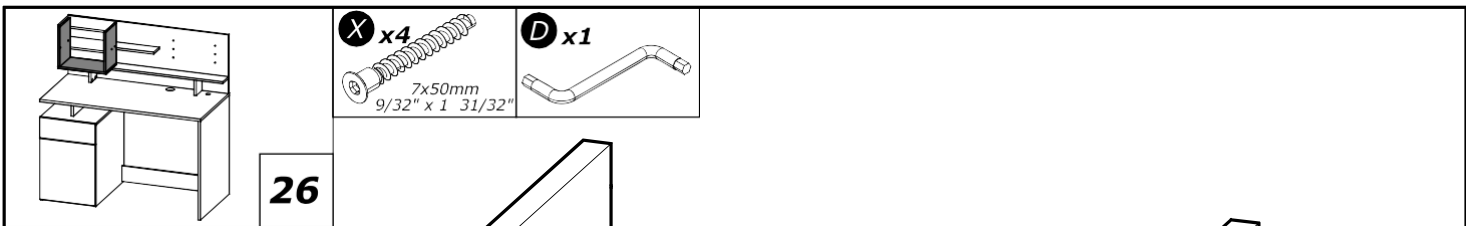
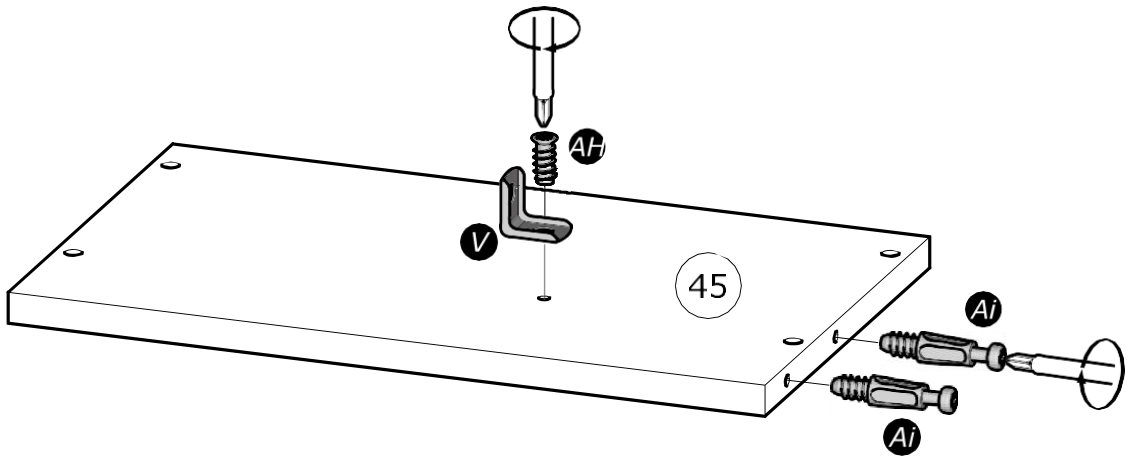
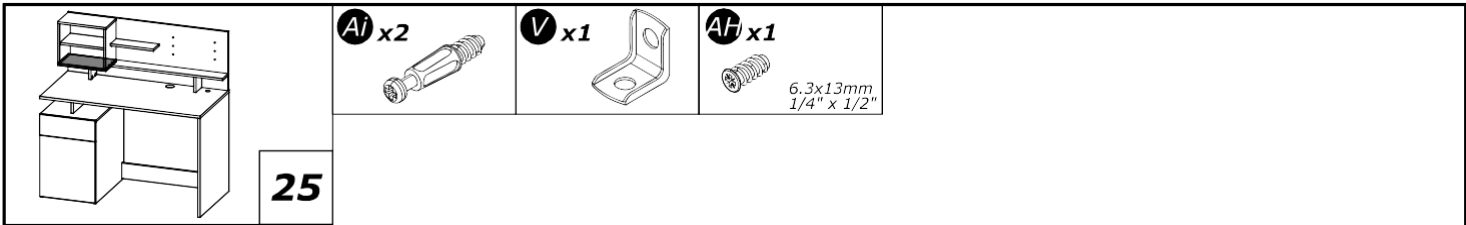

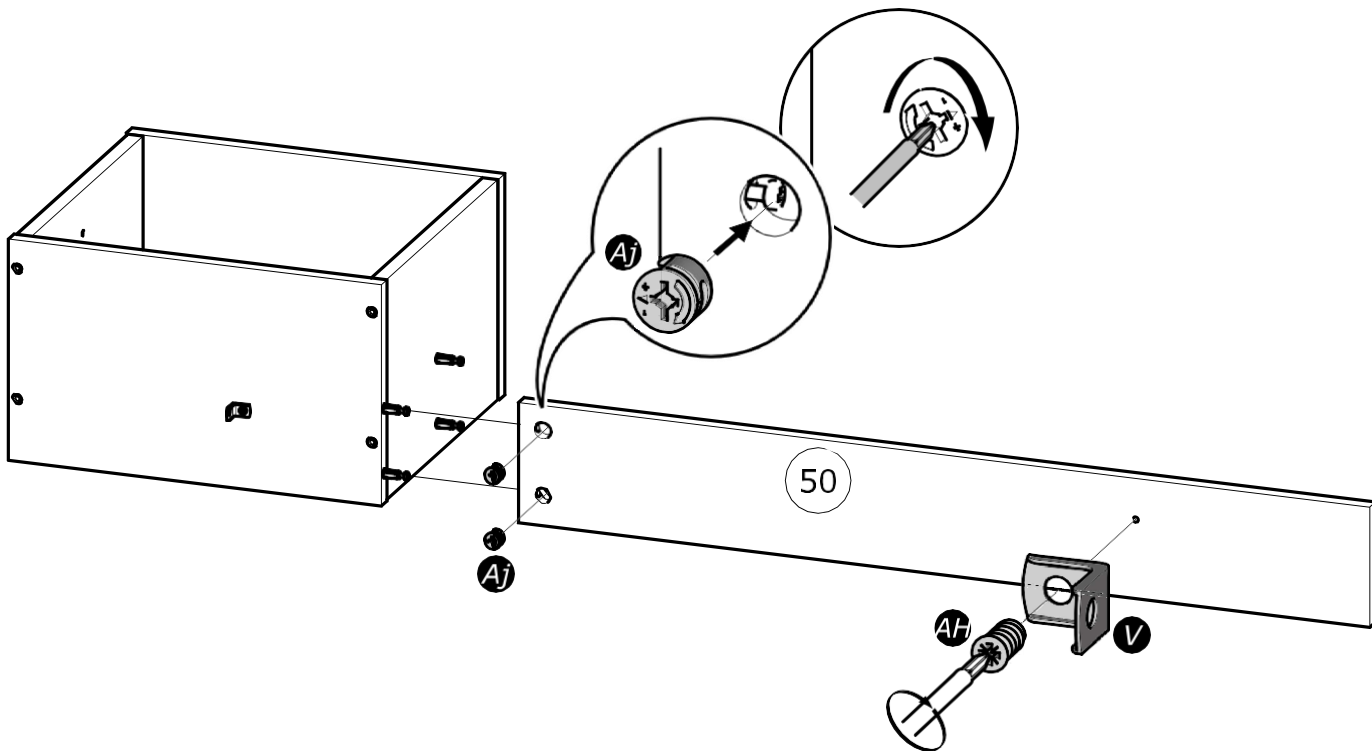
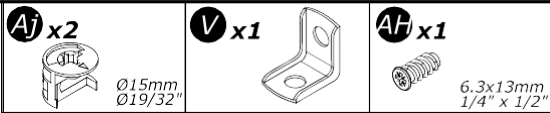
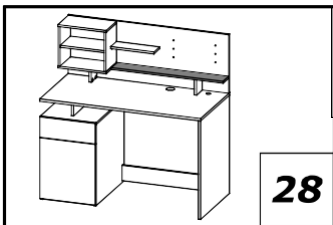
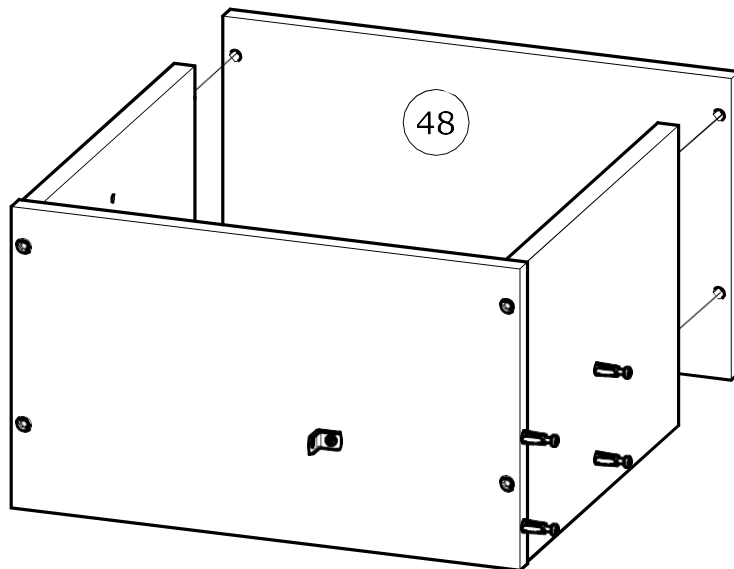
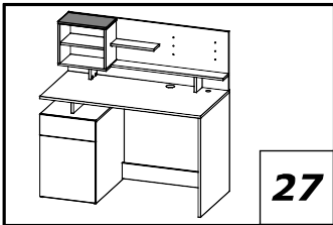

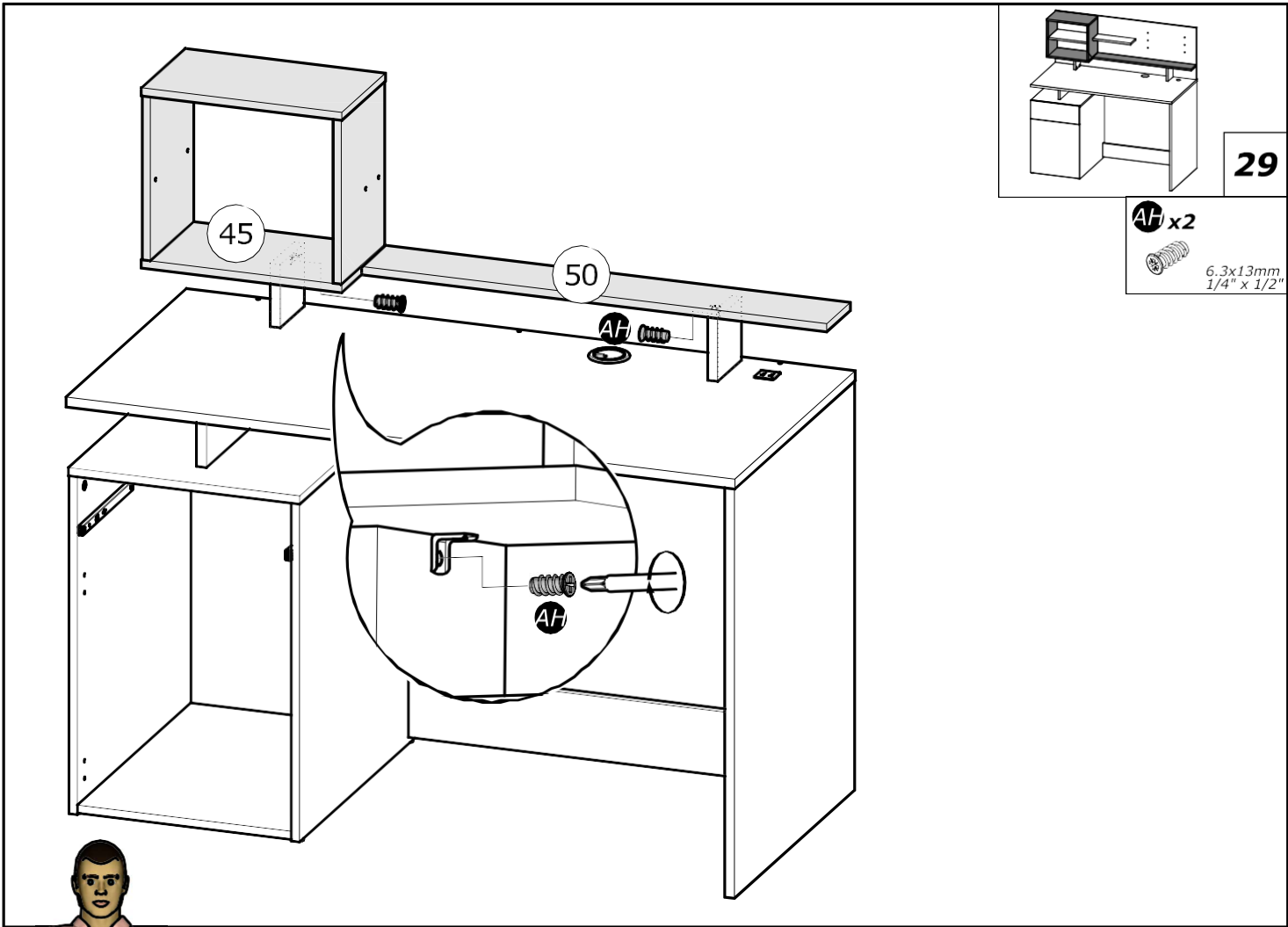

x2

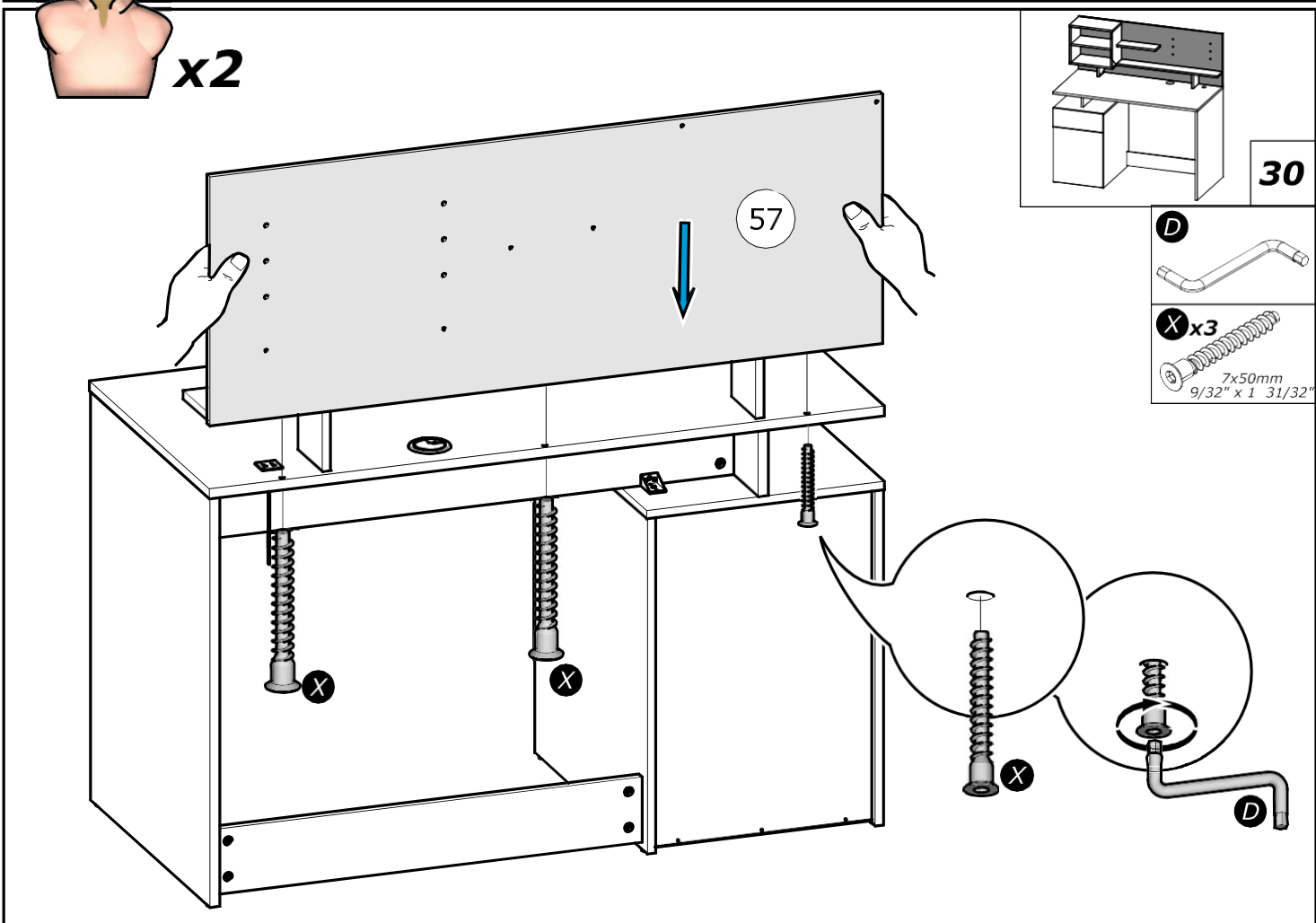

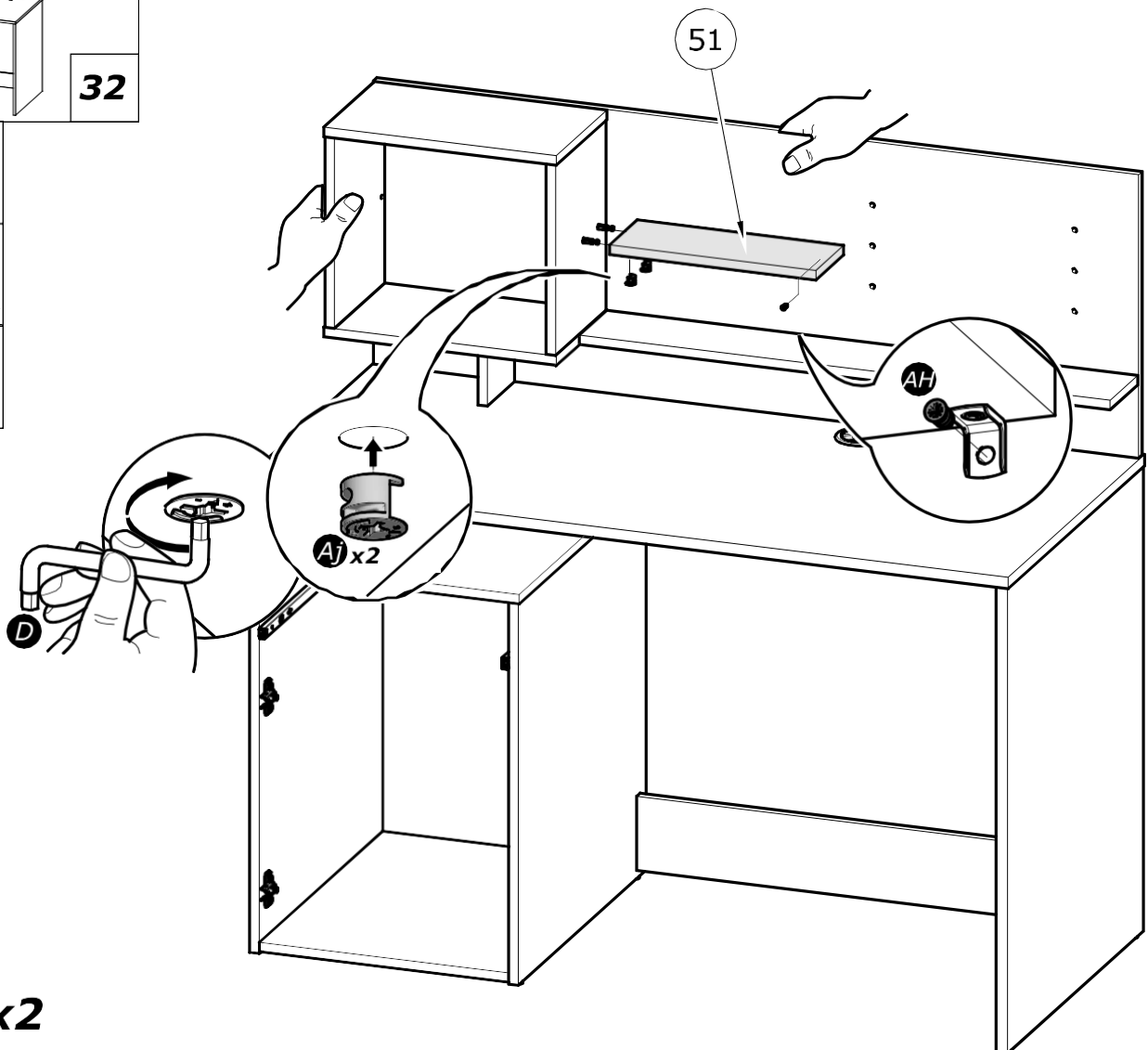
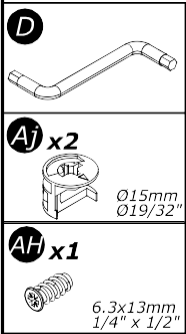
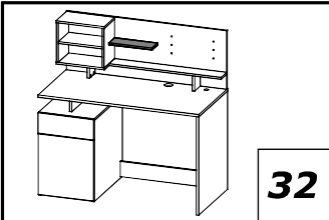
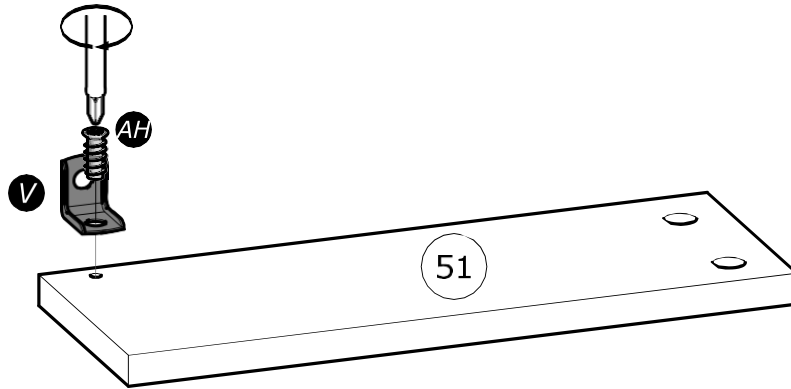
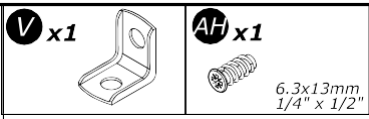
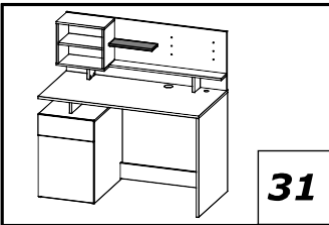

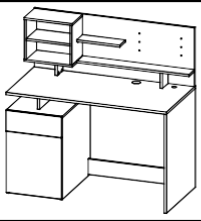

33

**K** x5  
3.5x30mm  
1/8" x 1 3/16"

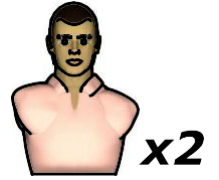
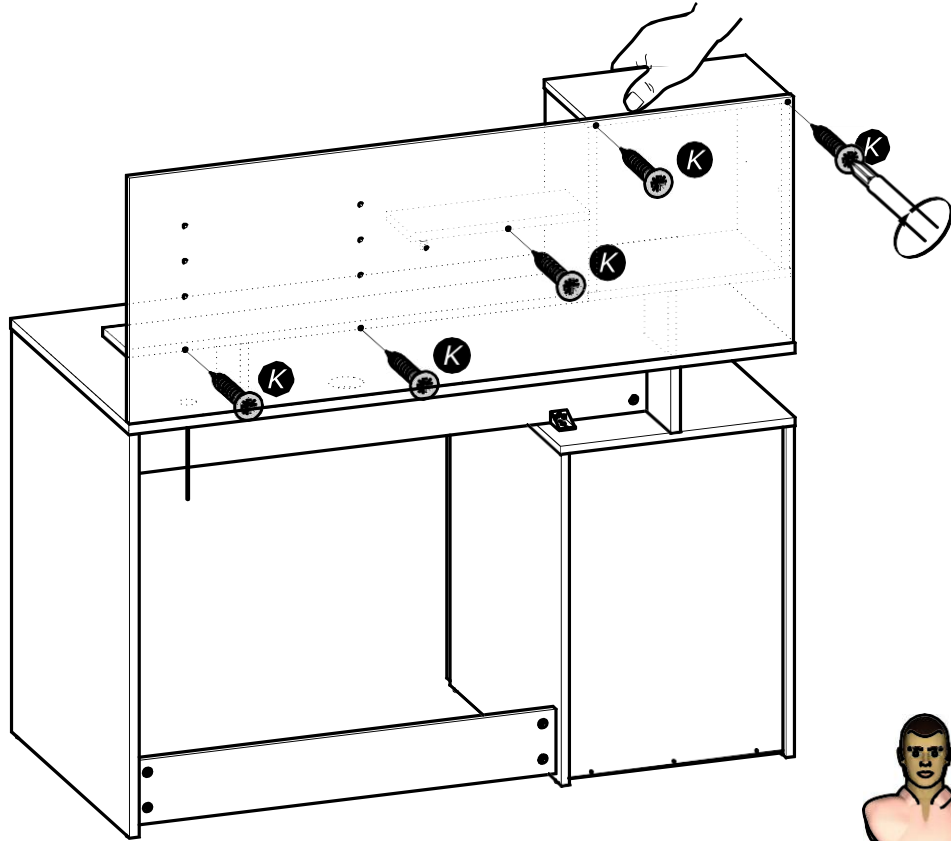

x2

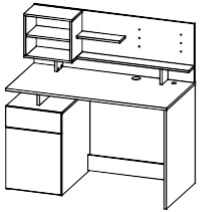

34

**Ac** x4

**Ad** x4  
3x16mm  
1/8" x 5/8"

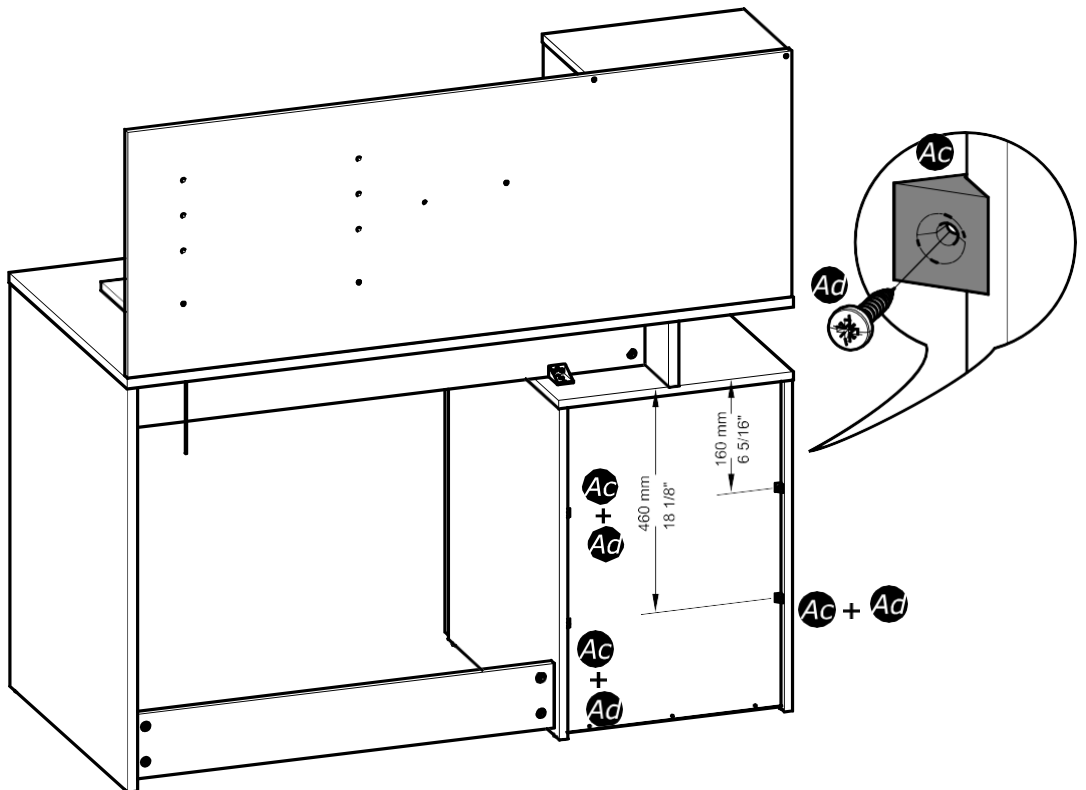

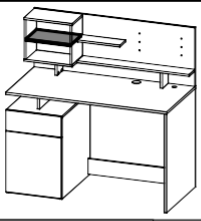

35

Ak x1

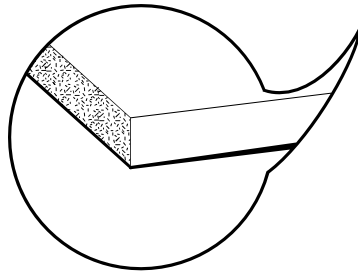
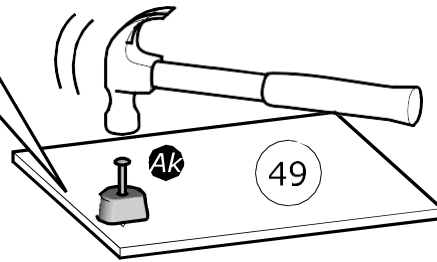
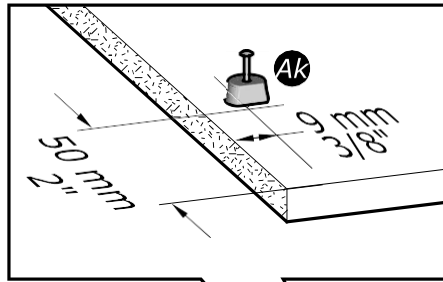

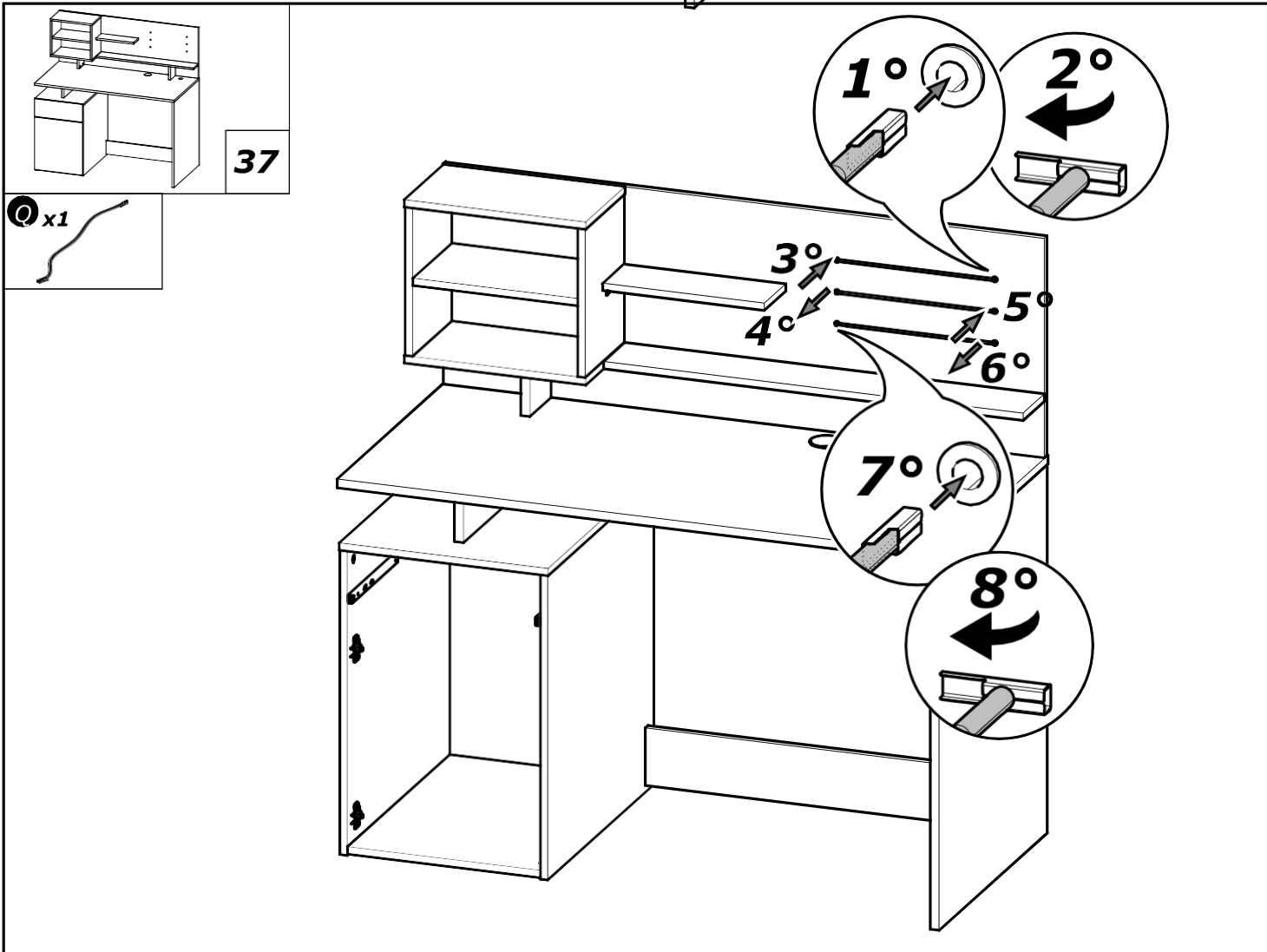
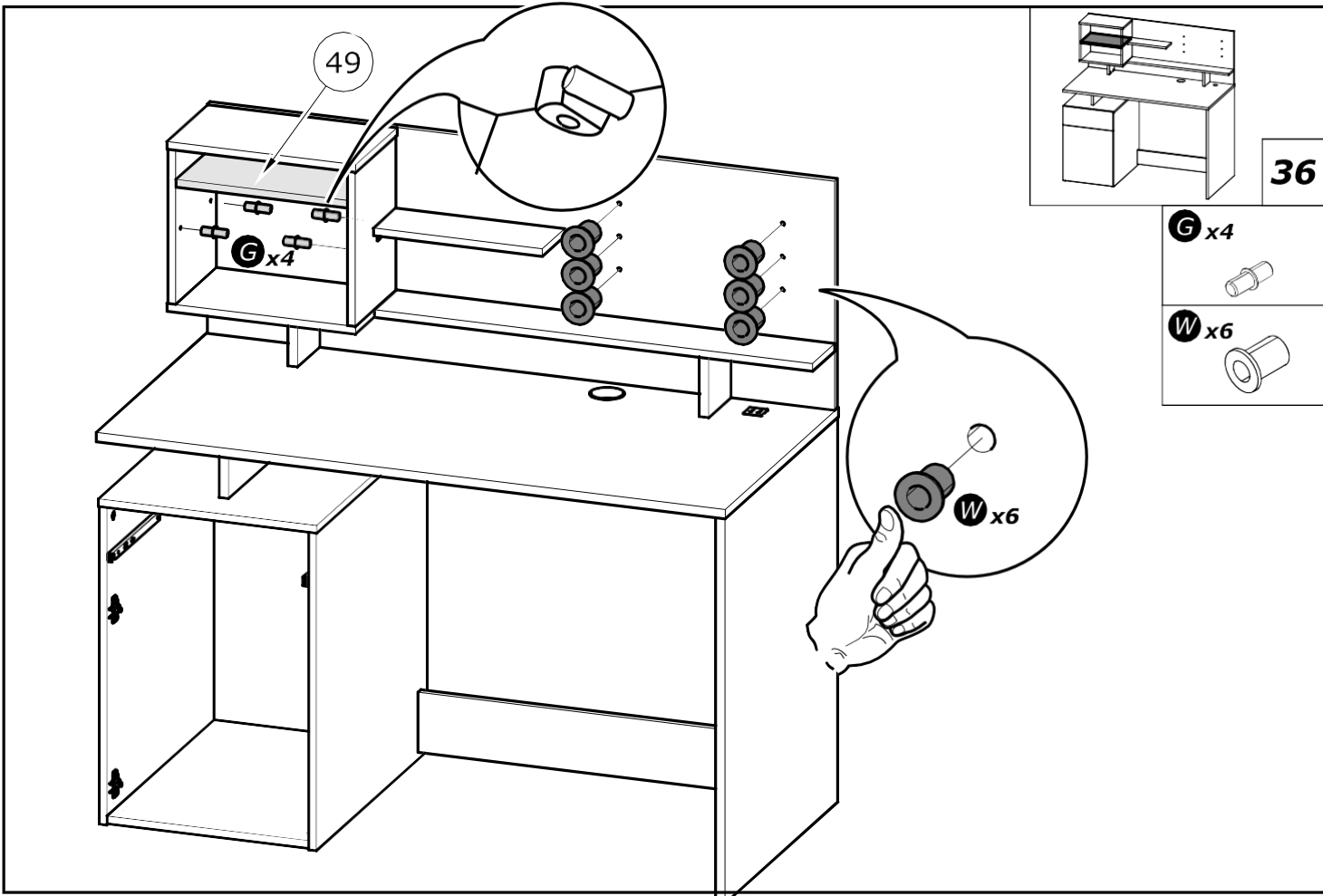

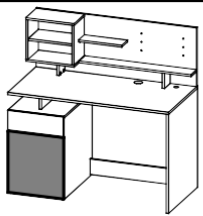

38

**M** x4  
3.5x15mm  
1/8" x 19/32"

**R** x1

**T** x2

**A1** x2  
4x30mm  
5/32" x 1 3/16"



www.Demeyere.fr

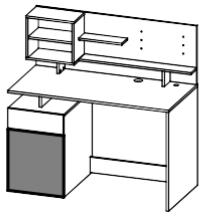
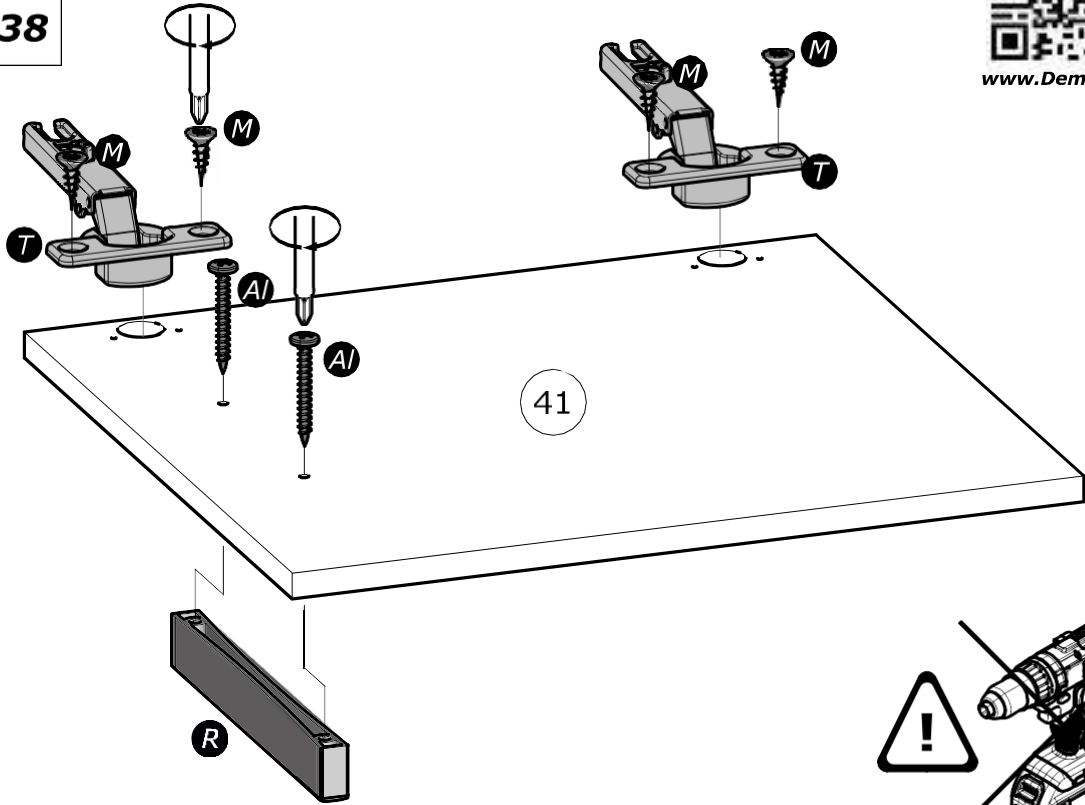

39

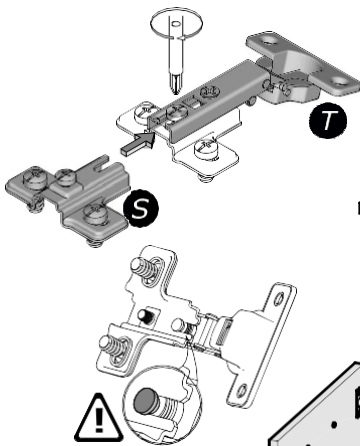

41

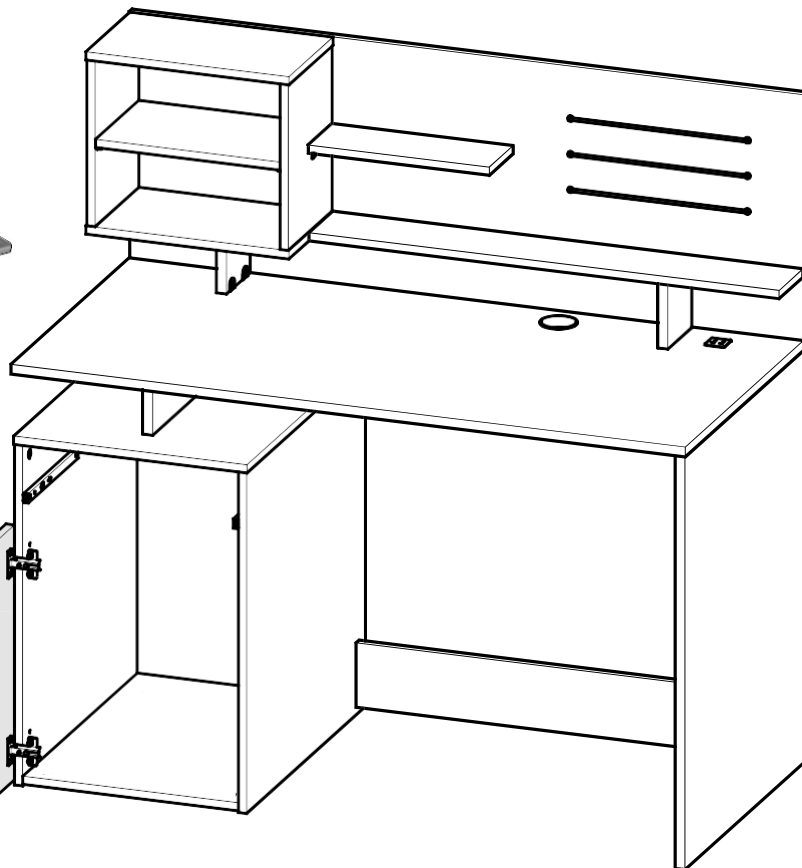

Aa

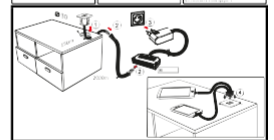

41

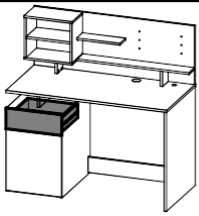

40

**N** x2  
4x9mm  
5/32" x 11/32"



[www.Demeyere.fr](http://www.Demeyere.fr)

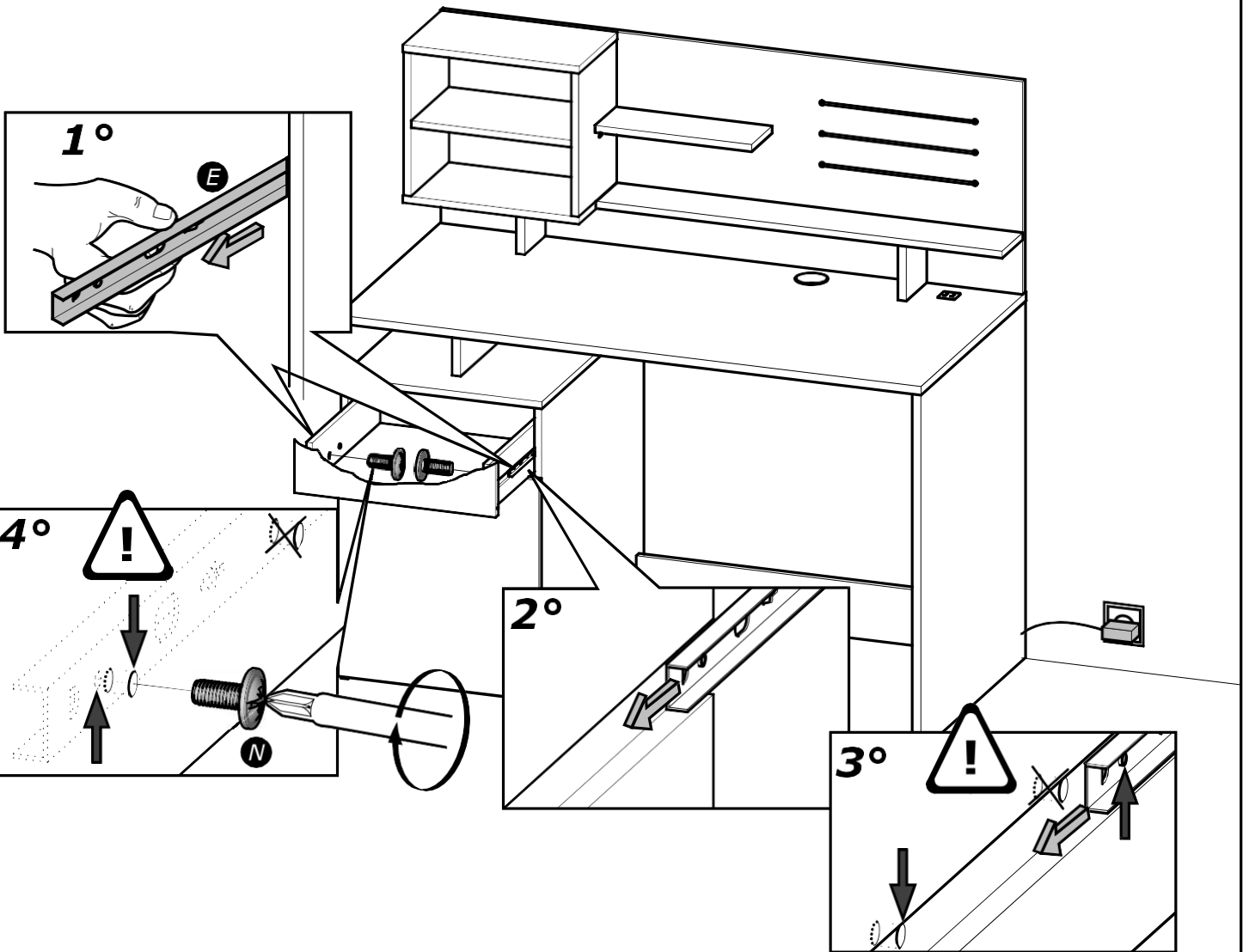

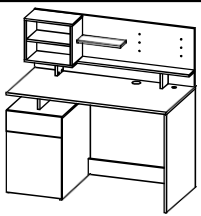

41

**J** x2  
3x12mm  
1/8" x 15/32"

**Ae** x1

**Af** x1

1°

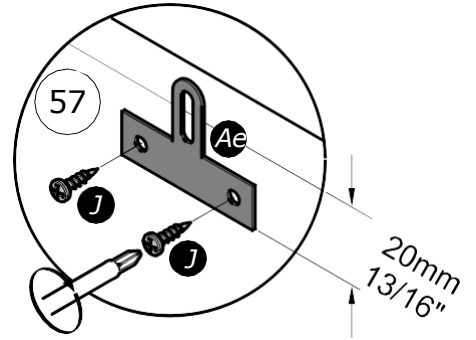
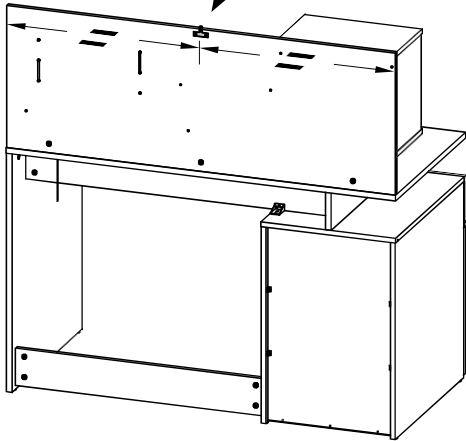

2°

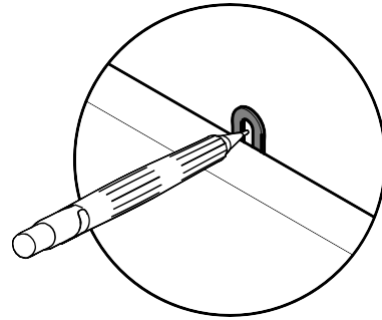
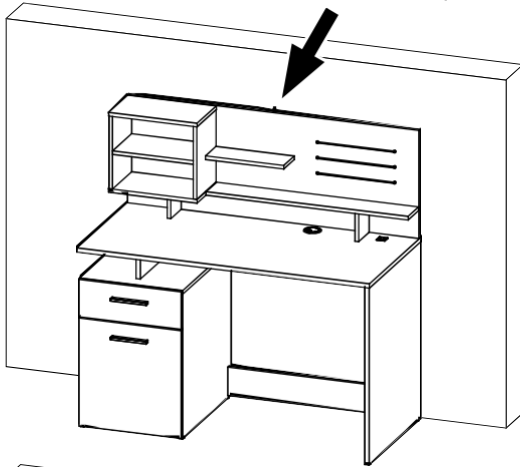

3°

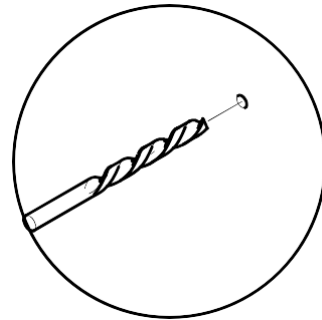
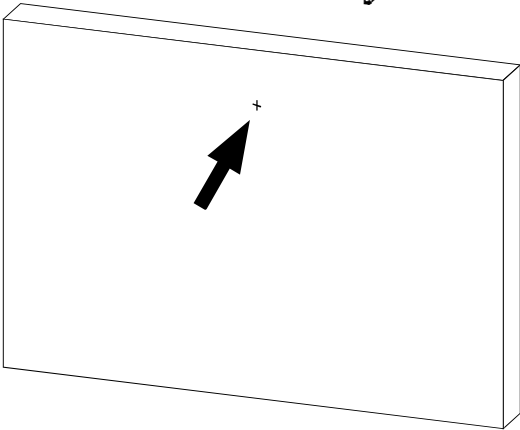

4°

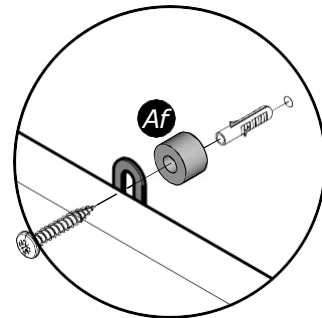
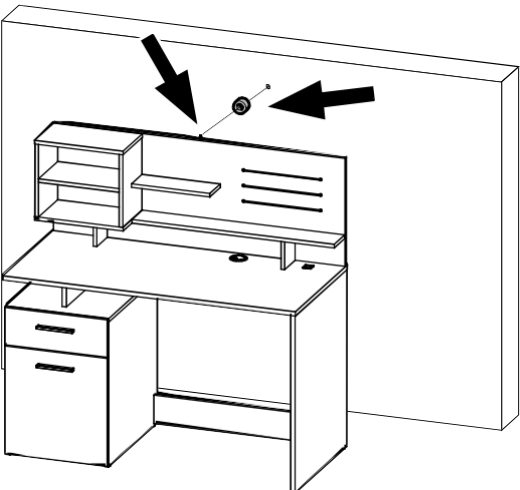

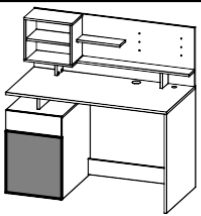

42



[www.Demeyere.fr](http://www.Demeyere.fr)

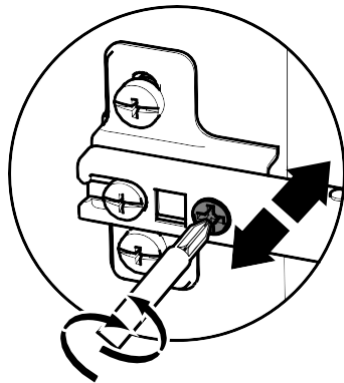
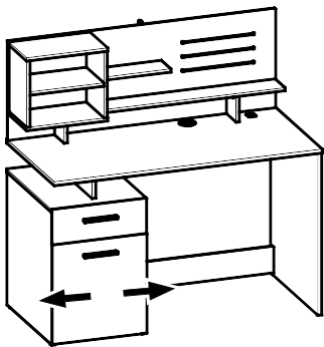
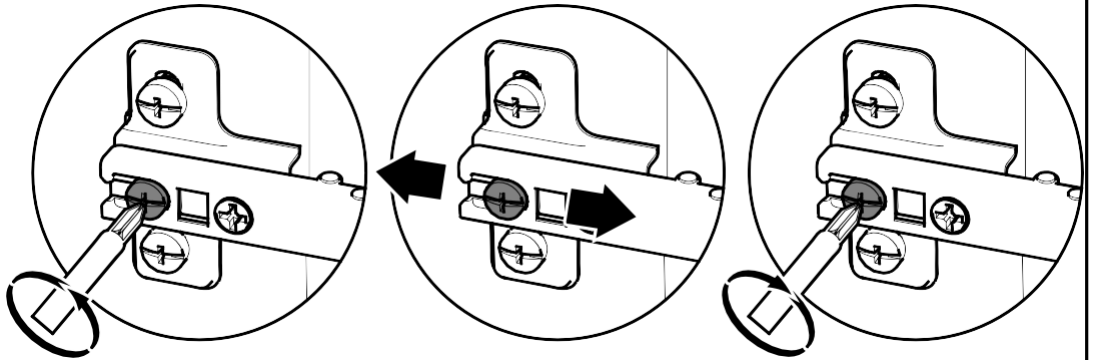
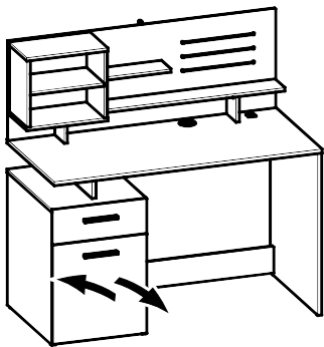
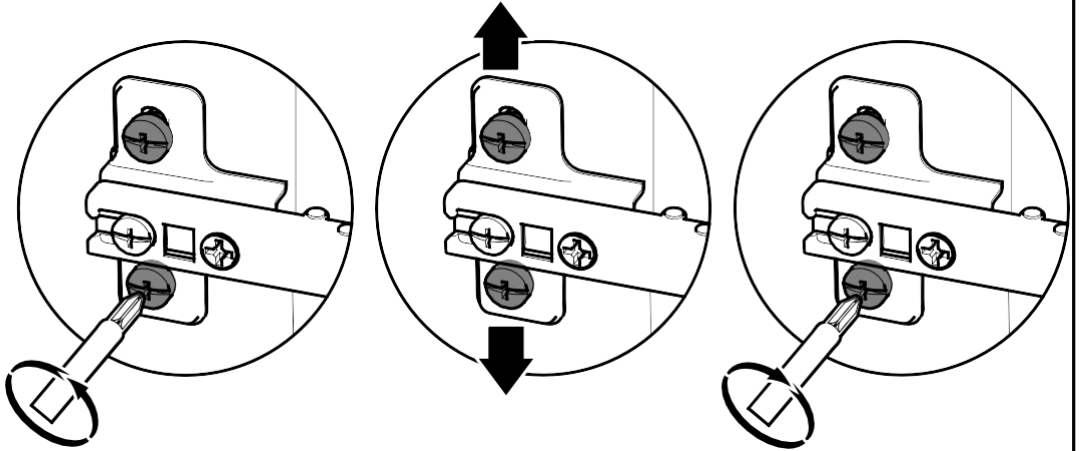
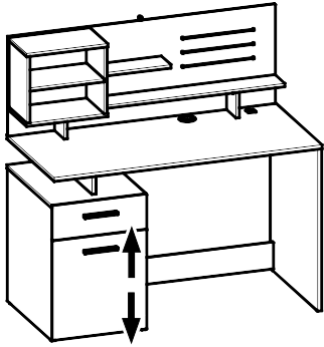

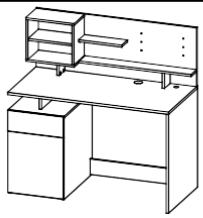

43

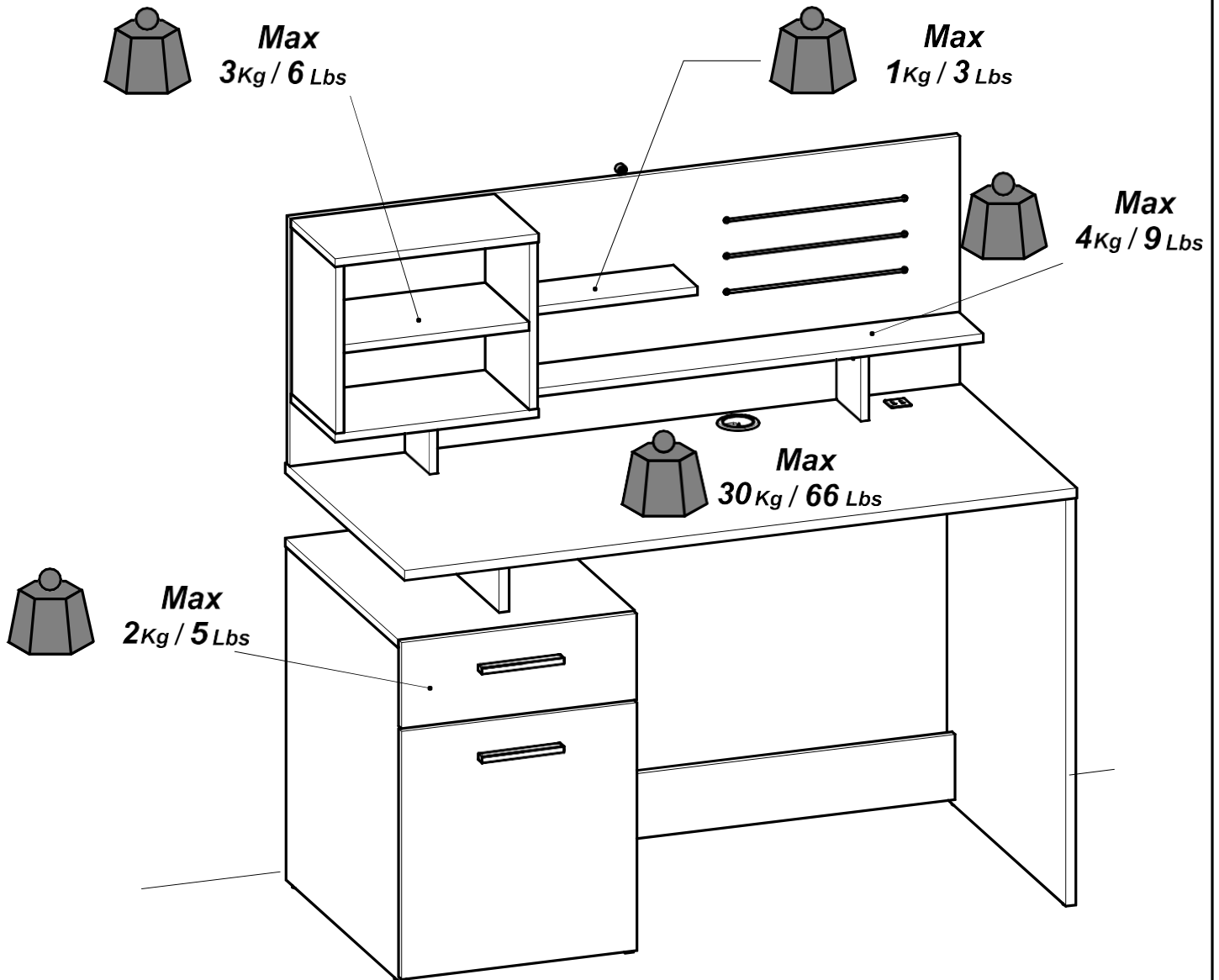

Les meubles contenant des panneaux à base de bois (panneaux de particules, panneaux de fibres, contreplaqué...) peuvent émettre des substances polluantes dans l'air intérieur.

Il est ainsi recommandé, après l'installation du meuble dans son logement, d'aérer fréquemment la pièce concernée pendant au moins quatre semaines" afin de réduire son exposition aux polluants émis par le meuble.