

# Conforama

## COCONUT APARADOR / COCONUT APPARADOR

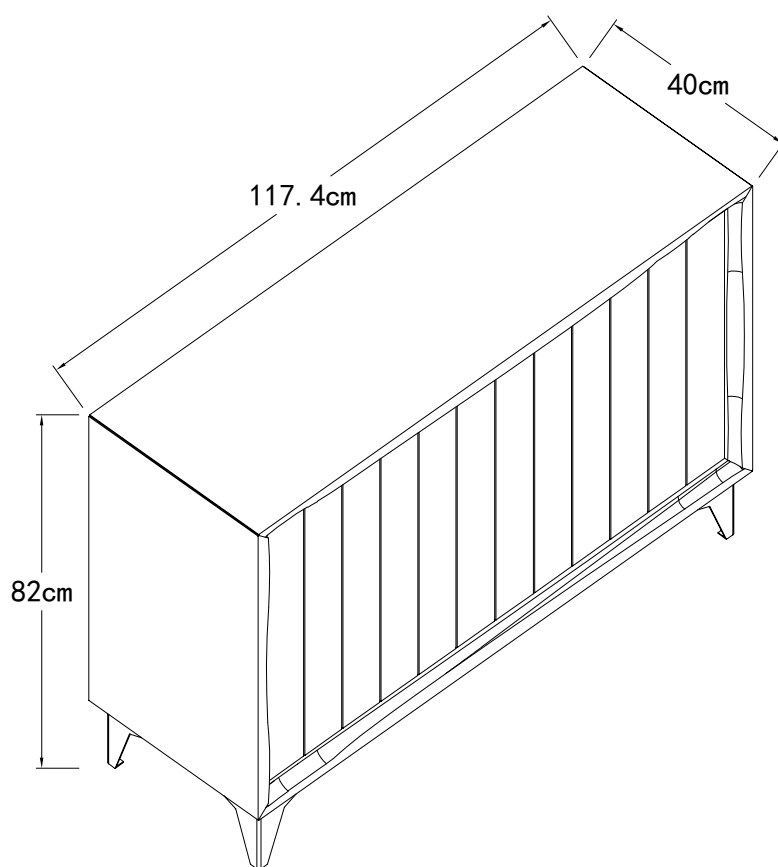

**CONFO CODE(S)**

**124344  
ROBLE & NEGRO/  
CARVALHO & PRETO**

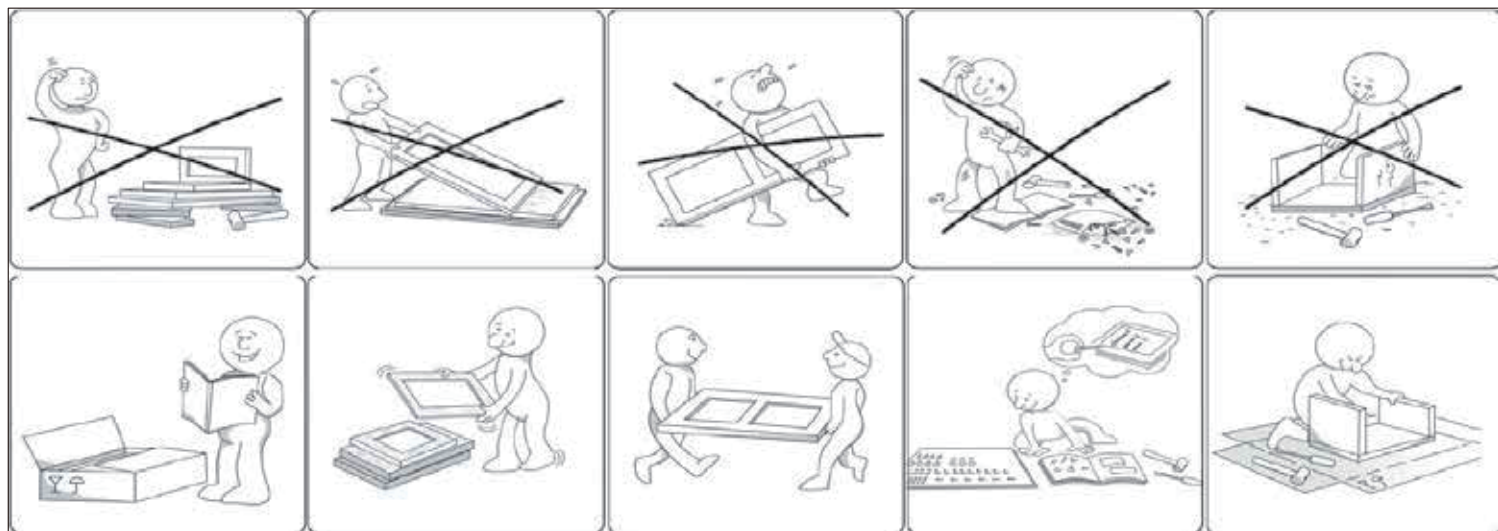

ES

## INFORMACION DE SEGURIDAD

**IMPORTANTE LEA ATENTAMENTE Y CONSÉRVELO PARA FUTURAS CONSULTAS**

Este mueble es para uso doméstico. Se requiere montaje.

Compruebe que dispone de toda la tornillería y de todas las piezas antes de comenzar el montaje.

No monte ni utilice el mueble si hubiera piezas rotas o dañadas o si faltaran piezas, y emplee únicamente piezas aprobadas por el fabricante.

Utilice únicamente las herramientas suministradas o recomendadas.

Apriete firmemente las fijaciones empleando las herramientas suministradas o recomendadas.

El montaje, el apuntalamiento o la manipulación incorrectos podrían conducir al debilitamiento del ensamblado o de las piezas.

Mantenga a los niños alejados durante el montaje. El producto contiene piezas pequeñas que podrían ingerirse.

Todas las uniones deberán apretarse adecuadamente y verificarse periódicamente, volviéndolas a apretar si fuera necesario.

No desplace un mueble que esté cargado.

**IMPORTANTE:** Para evitar que el mueble pueda volcarse accidentalmente, deberá fijarse a la pared.

Mueble que contiene paneles con base de madera (tableros de partículas, fibras, contrachapado)

que pueden emitir contaminantes al aire en interiores. Consiguientemente, se le aconseja que,

una vez instalado el mueble en su ubicación, ventile la sala frecuentemente durante al menos cuatro semanas para reducir la exposición a los contaminantes emitidos por el mismo.

PT

## INFORMACAO DE SEGURANCA

**IMPORTANTE! LER ATENTAMENTE E GUARDAR PARA REFERÊNCIA FUTURA**

Este mobiliário destina-se apenas a uso doméstico. Mobiliário a ser montado pelo utilizador.

Certifique-se de que possui todas as ferragens e peças em bom estado antes de iniciar a montagem.

Não monte nem use o mobiliário se tiver peças partidas,

danificadas ou em falta, e use apenas peças aprovadas pelo fabricante.

Use apenas ferramentas fornecidas ou recomendadas.

Aperte bem os fixadores usando as ferramentas fornecidas ou recomendadas.

Uma montagem, suporte ou manuseamento incorretos pode dar origem a um enfraquecimento da montagem e/ou das peças.

Mantenha as crianças pequenas afastadas durante a montagem.

O produto contém peças pequenas suscetíveis de serem engolidas.

Todas as juntas deverão ser devidamente apertadas e verificadas regularmente, e apertadas novamente, se necessário.

Não mova o mobiliário com carga.

**IMPORTANTE:** Para evitar que o mobiliário caia acidentalmente, tem de ser fixado a uma parede.

O mobiliário que contenha painéis à base de madeira (painel de aglomerado, placa de fibra, contraplacado, etc.)

pode emitir poluentes para o ar no interior. Assim, aconselhamos que, após instalar o mobiliário no respetivo local,

ventile frequentemente a divisão durante, pelo menos, quatro semanas, para reduzir a exposição aos poluentes emitidos pelo mobiliário.

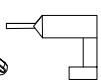
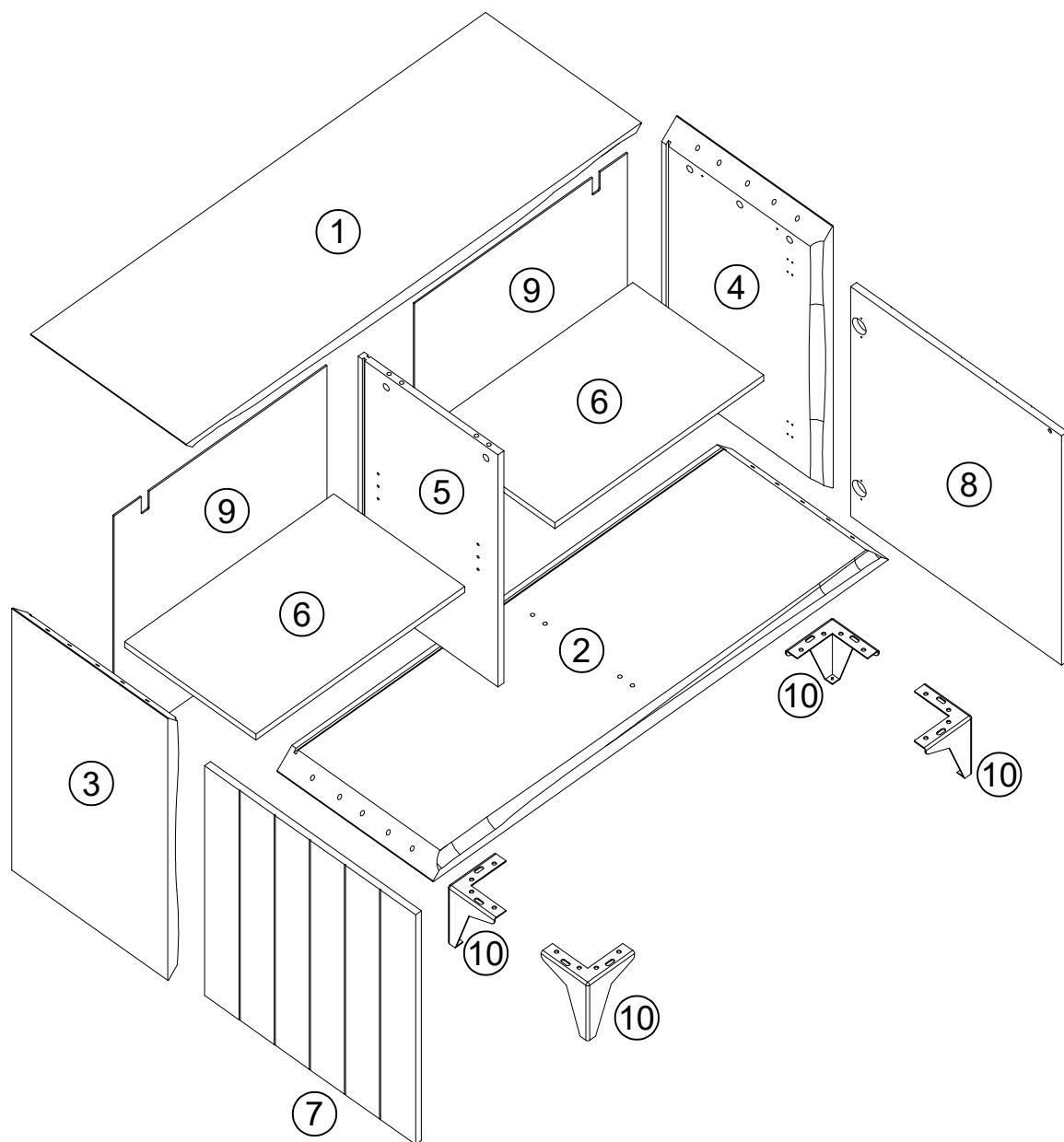

NON FOURNI(S)  
NOT INCLUDED













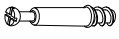

2

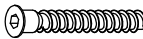

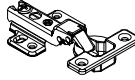
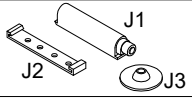
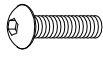
50  
MIN

NO.	TAILLE SIZE	QTE QTY	CTN NO.	NO.	TAILLE SIZE	QTE QTY	CTN NO.
①	1167x400x40mm	X1	1/2	⑥	536x336x15mm	X2	1/2
②	1167x400x40mm	X1	1/2	⑦	589x541x15mm	X1	2/2
③	670x400x40mm	X1	1/2	⑧	589x541x15mm	X1	2/2
④	670x400x40mm	X1	1/2	⑨	605x546x5mm	X2	2/2
⑤	595x358.5x15mm	X1	2/2	⑩	140x140x147mm	X4	1/2

# Quincaillerie de montage/Hardware

<b>A x6</b>  M6x45mm	<b>B x2</b>  M6x35mm	<b>C x14</b>  Ø15mm	<b>D x12</b>  Φ8x30mm	<b>E x42</b>  M3.5x14mm	<b>F x8</b>  M7x70mm	<b>G x12</b>  14x14x9mm
<b>H x2</b>  65x15x32mm	<b>I x4</b>  105mm	<b>J x2</b>  82x14x20mm	<b>K x16</b>  M6x20mm	<b>L x8</b>  Φ5x16mm	<b>M x8</b>  Ø20mm	<b>N x4</b>  20x20x16mm
<b>O x10</b>  M4x14mm	<b>P x1</b>  4#					

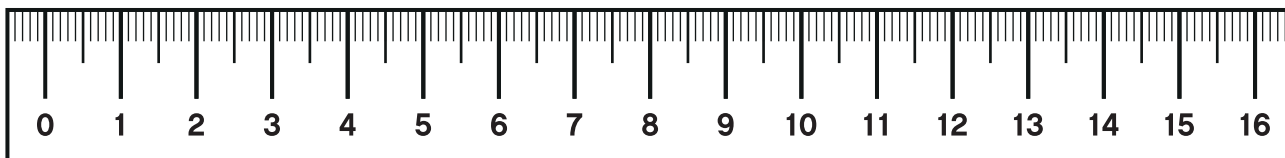
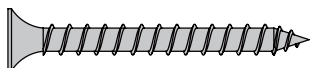

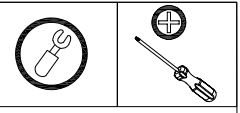

# 1

B x2



M6x35mm

E x4



M3.5x14mm

J x2

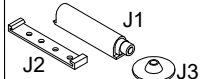

82x14x20mm

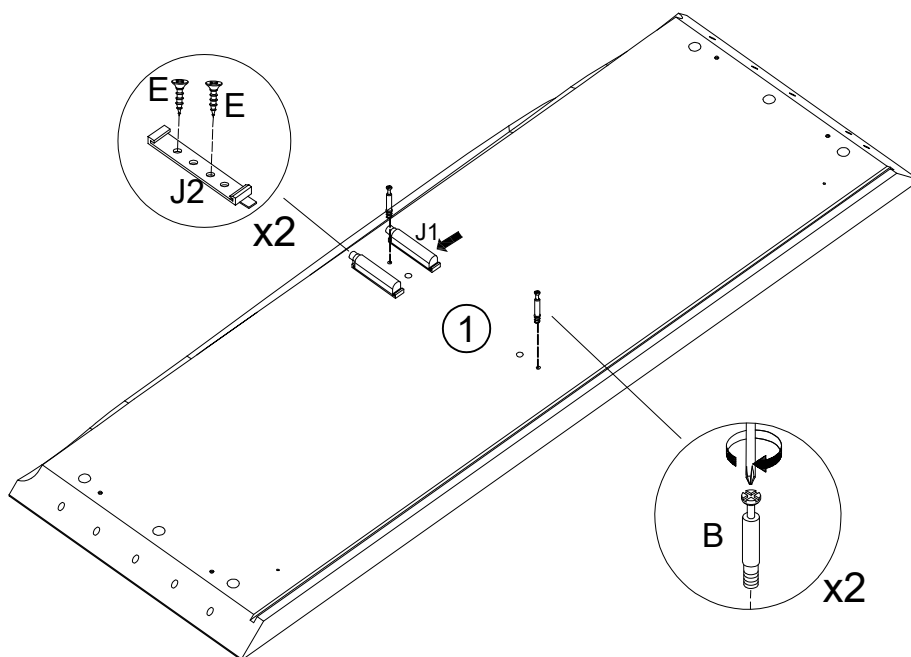

# 2

H x2



65x15x32mm

N x4



20x20x16mm

O x6



M4x14mm

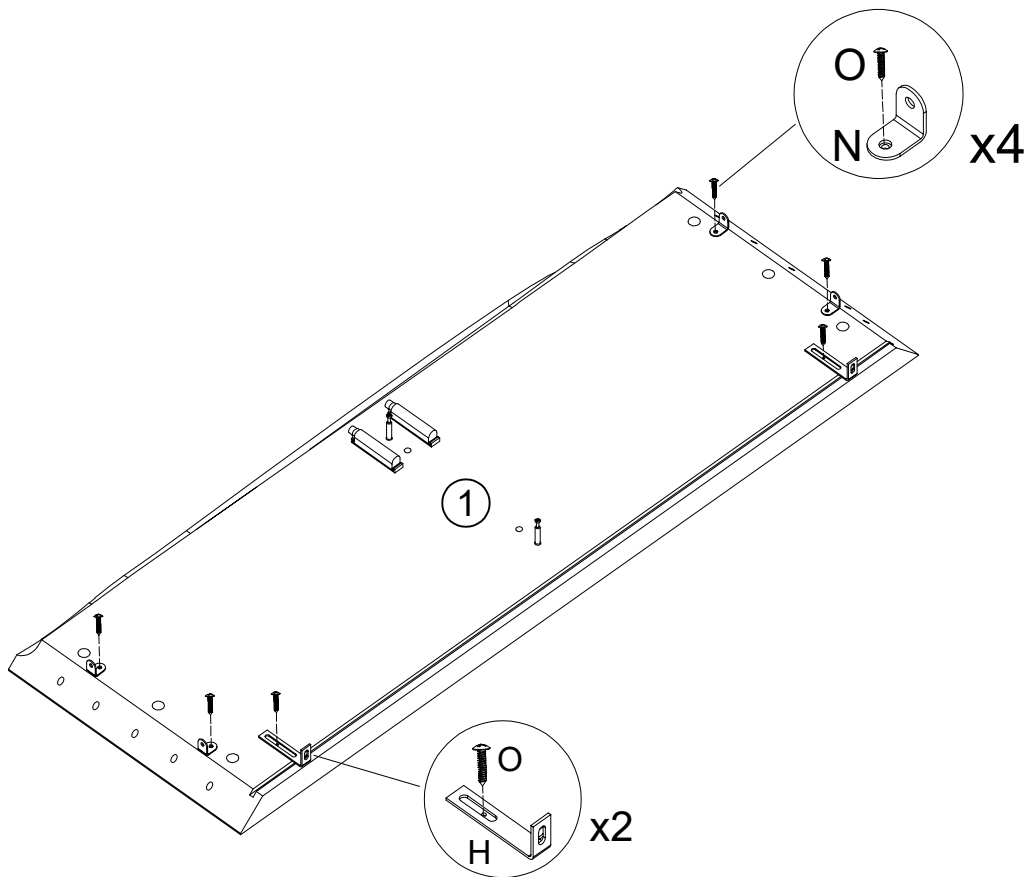

# 3

A x6



C x6



Ø15mm

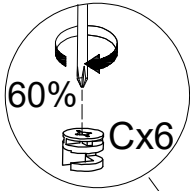

Ax6

1

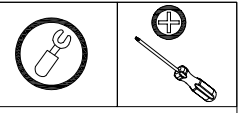

# 4

C x8



Ø15mm

D x6

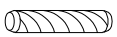

Φ8x30mm

M x8



Ø20mm



4

5

3

Cx8

Mx8

Dx6

1

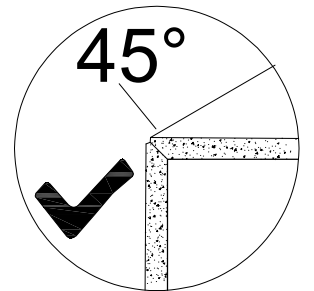
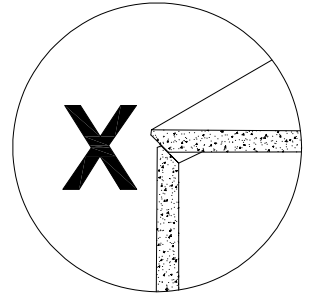
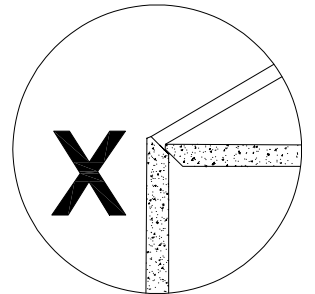
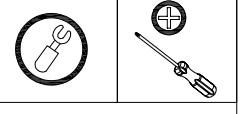

5

O x4



M4x14mm

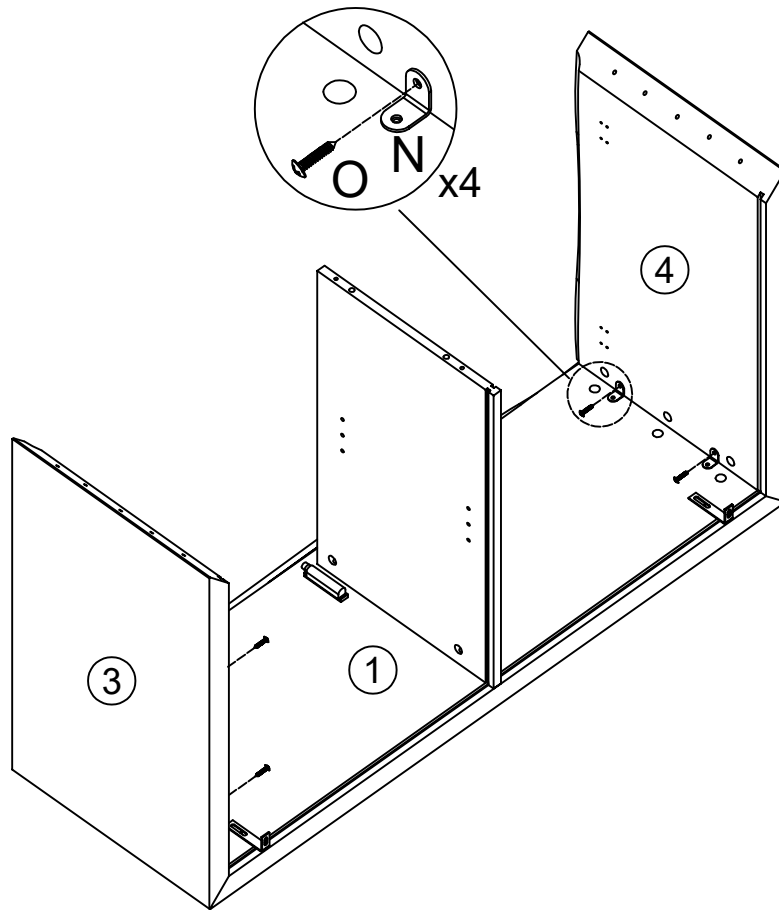

6

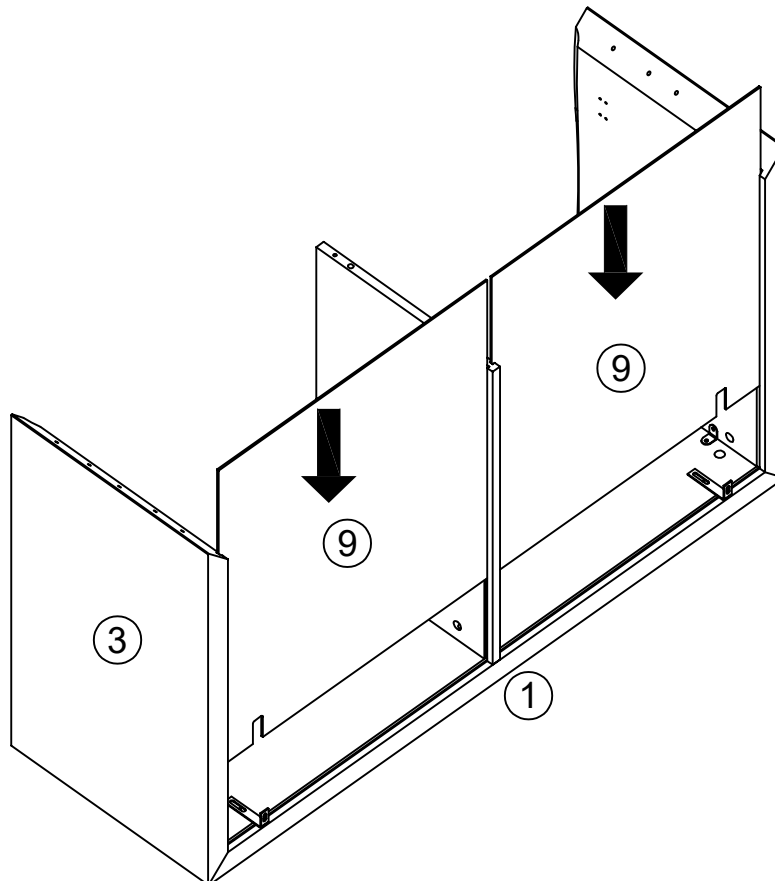

# 7

F x8



M7x70mm

D x6

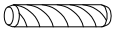

Φ8x30mm

P x1



4#

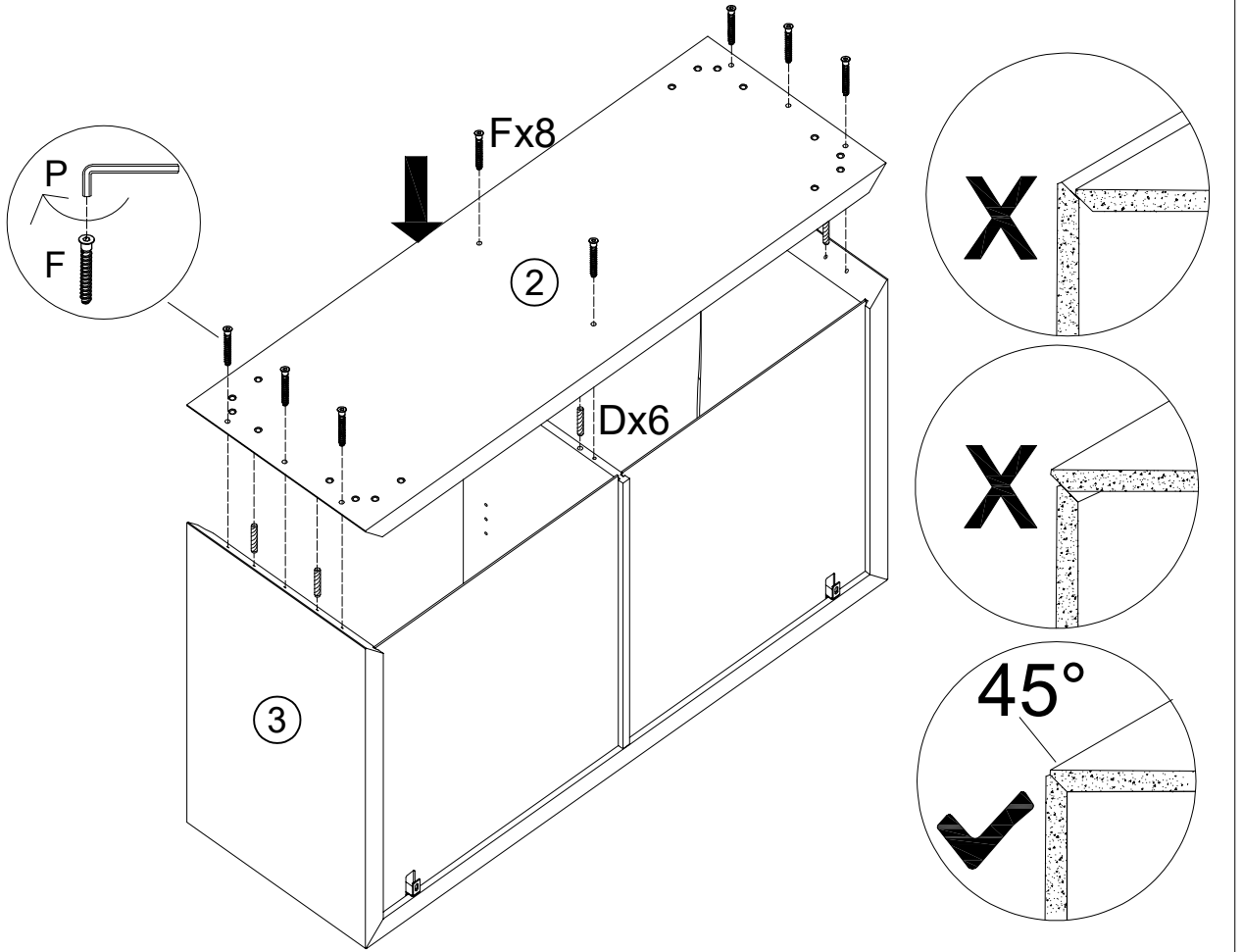

# 8

K x16

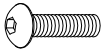

M6x20mm

P x1



4#

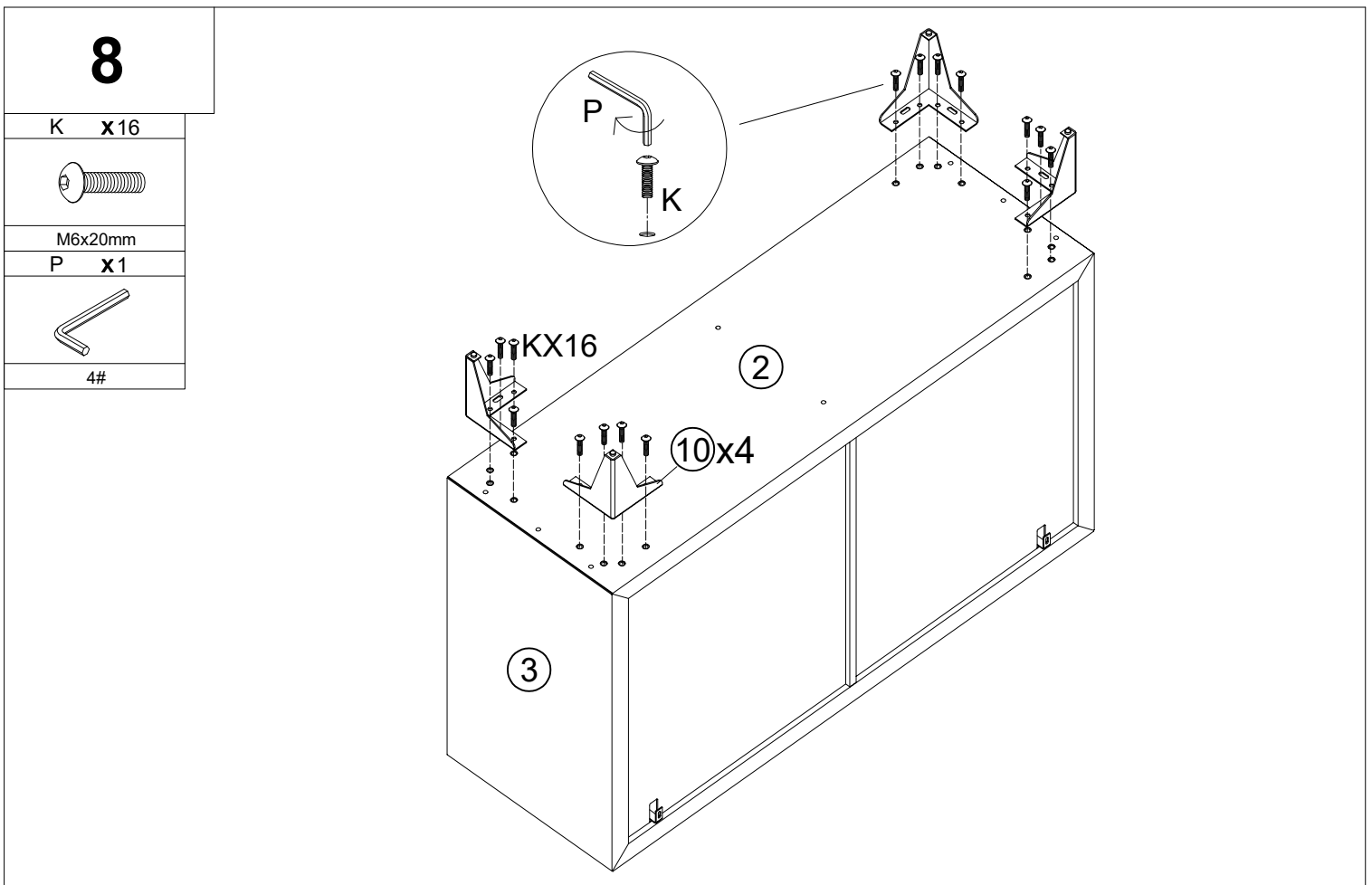

9

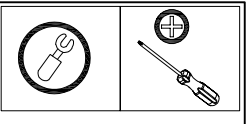

G x12



E x12



M3.5x14mm

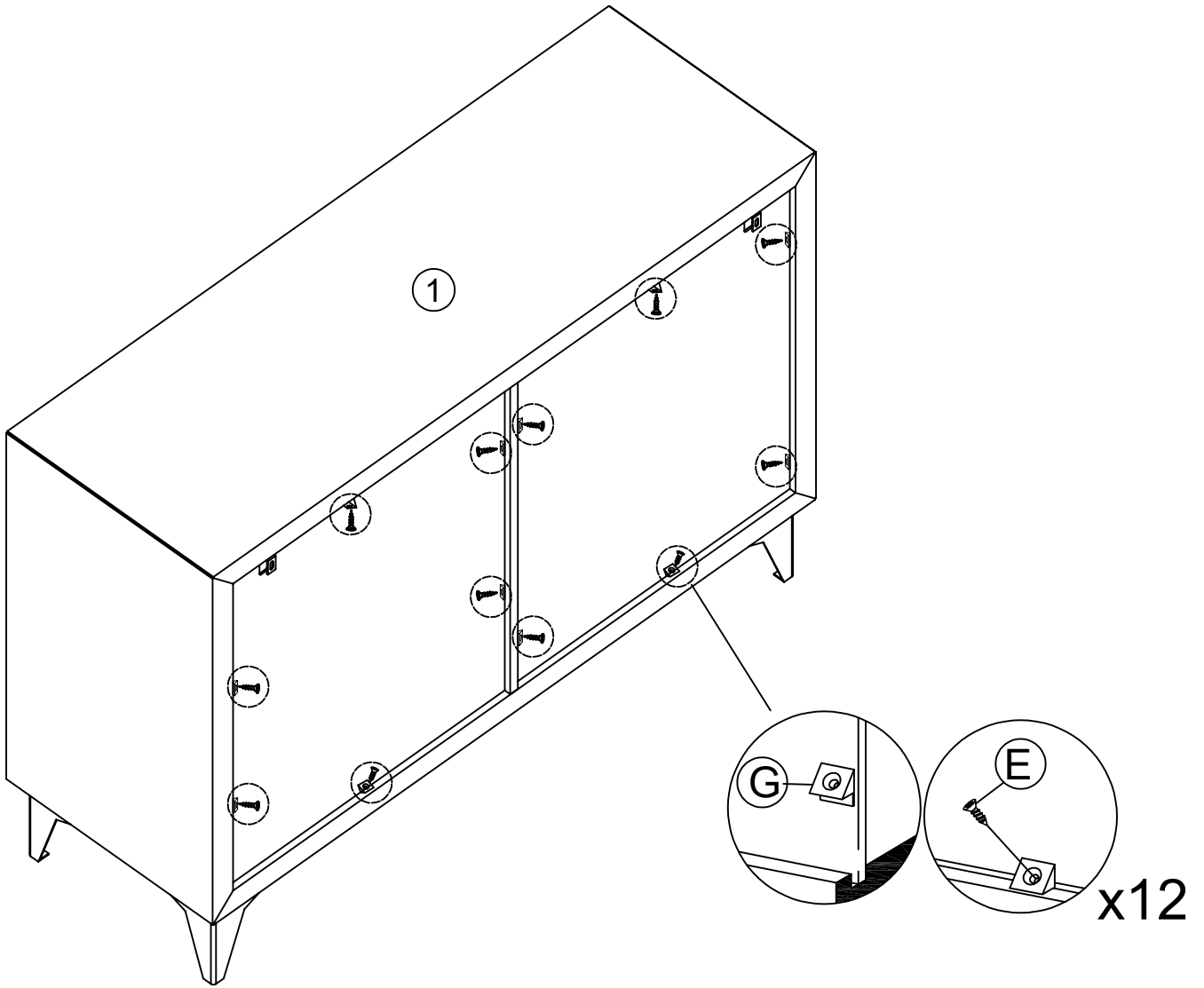

# 10



X2

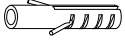

no incluido / não incluído

X2



no incluido / não incluído

! Il existe une grande diversité de types de murs ou cloisons, c'est la raison pour laquelle nous ne pouvons vous fournir le type exact de fixation. Il est nécessaire d'identifier le type de paroi à laquelle vous allez fixer ce produit afin de vous procurer les fixations appropriées. Voici quelques exemples de fixations conseillées pour:

LES MURS PLEIS		LES CLOISONS CREUSES		
<p>Cheville nylon "FISCHER"</p>	<p>Cheville d'ancrage métal</p>	<p>Cheville d'ancrage A ailettes en nylon</p>	<p>Cheville métallique A expansion</p>	<p>Cheville "MOLLY"</p>
<p>Utiliser une taille de forêt adaptée à la quincaillerie utilisée et au type de mur.</p>				

ES: Los tornillos requeridos para la unión de pared/mueble, que dependen del tipo de pared, no se suministran. Asegúrese de que la tornillería sea adecuada para su sustrato. En caso de duda, consulte a un especialista.

PT: Os parafusos necessários para a junção da parede/mobiliário, que dependem do tipo de parede, não são fornecidos. Certifique-se de que as ferragens são as adequadas ao seu substrato. No caso de dúvida, consulte um especialista.

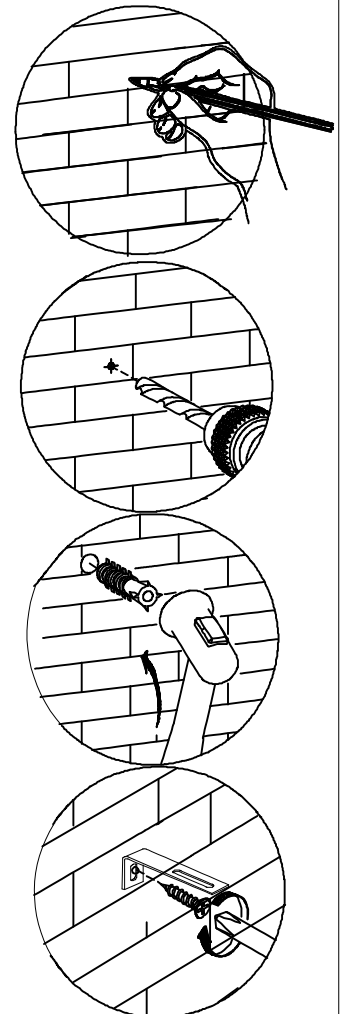
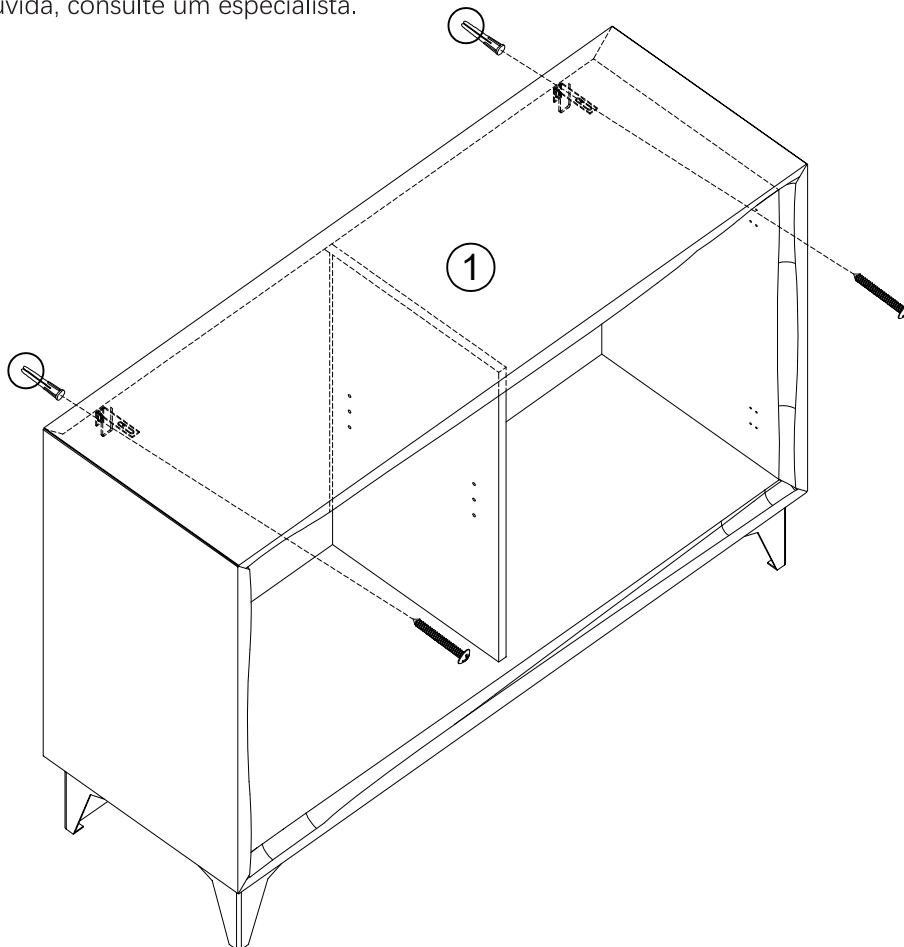

# 11

L x8

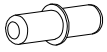

Φ5x16mm

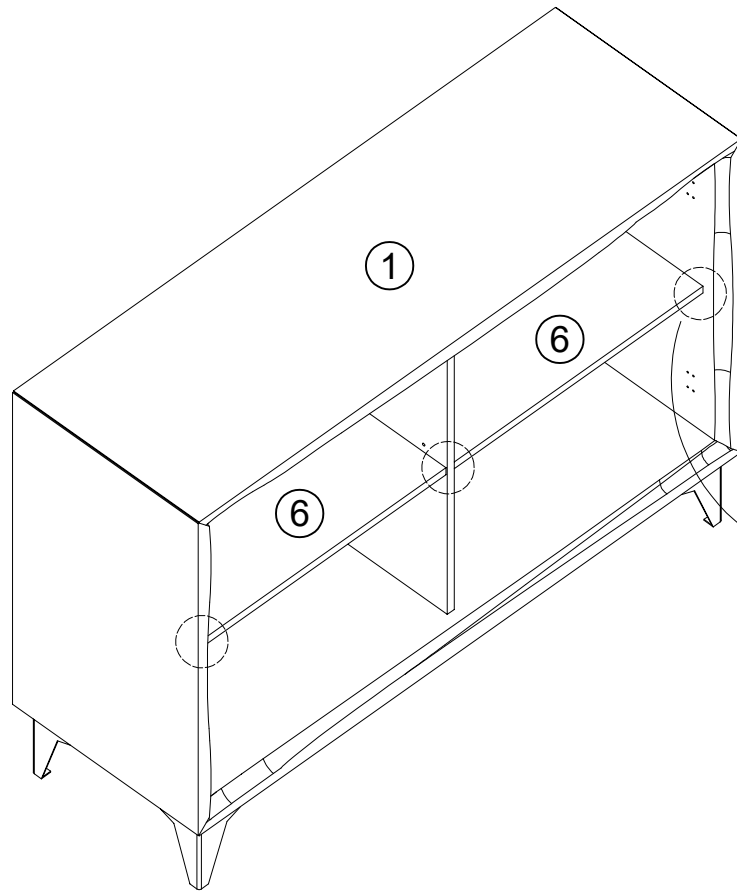

x8

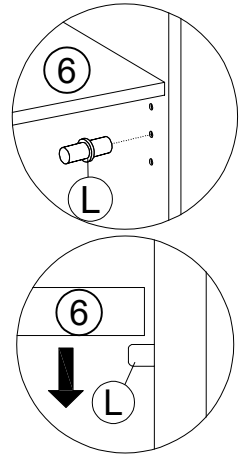

# 12

E x10

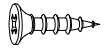

M3.5x14mm

I x4

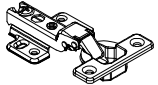

105mm

J x2

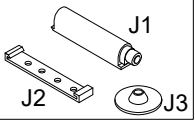

J2

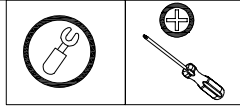
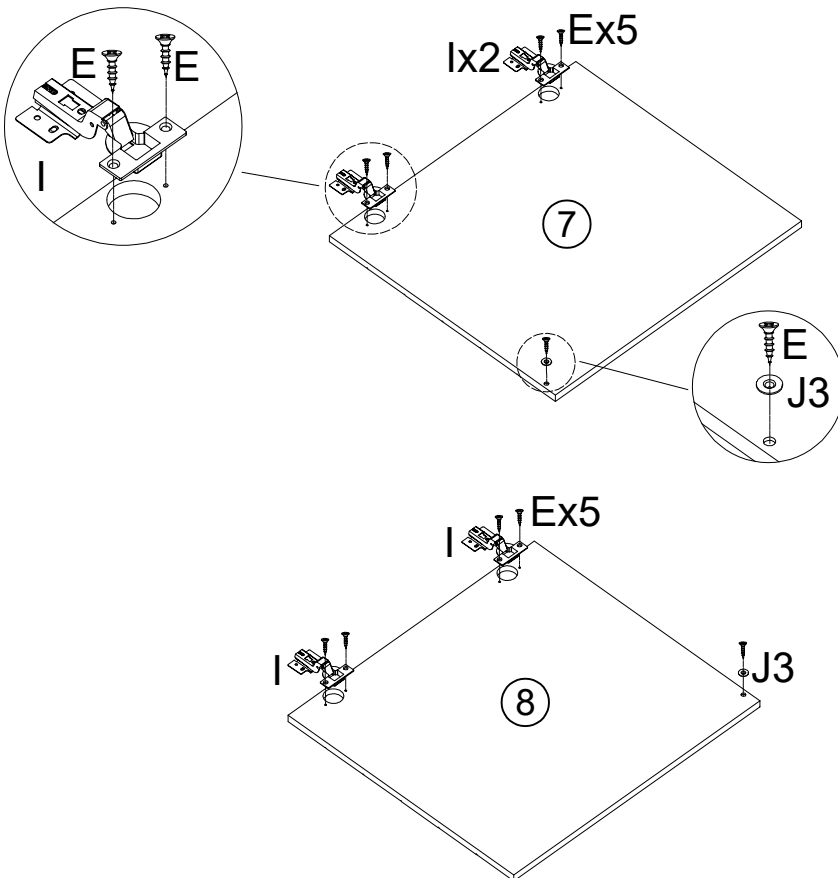

# 13

E x16

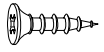

M3.5x14mm

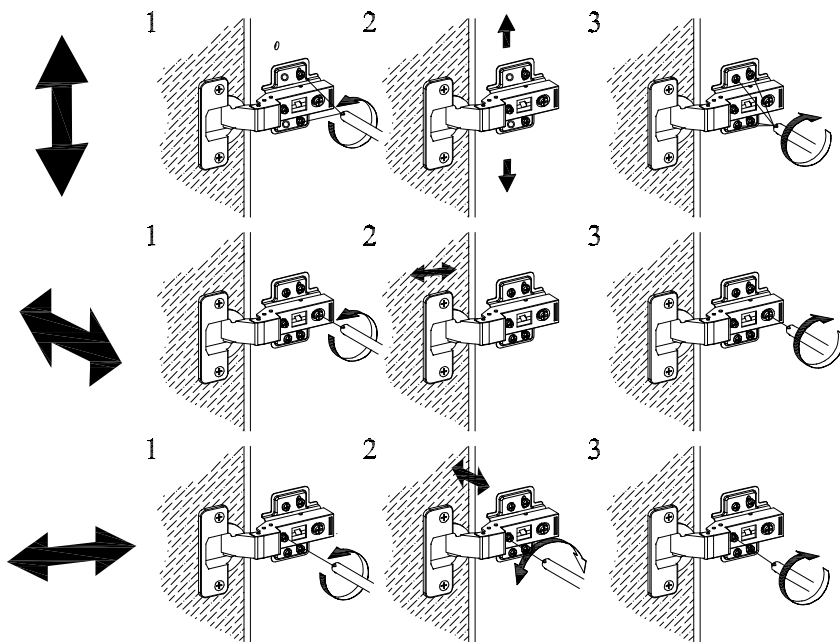
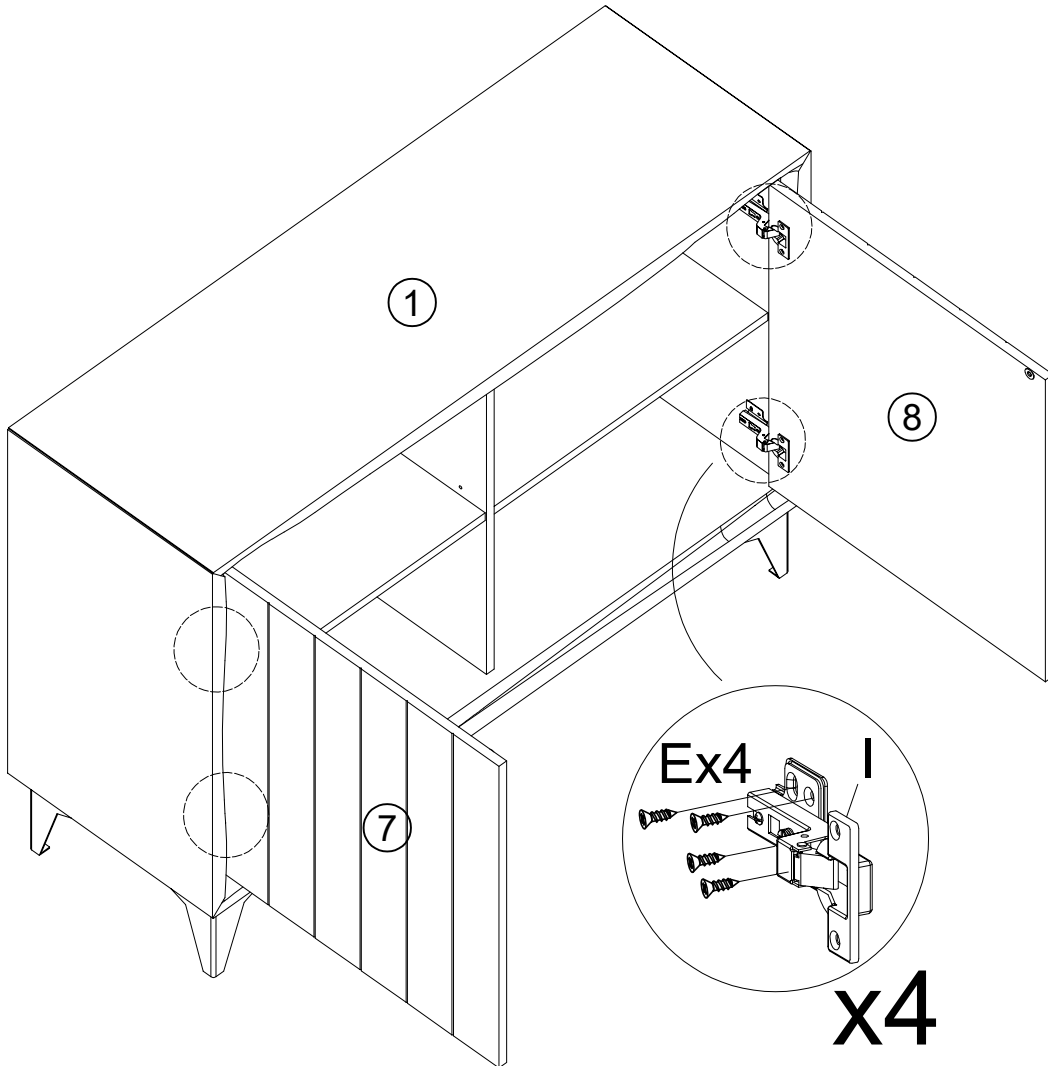
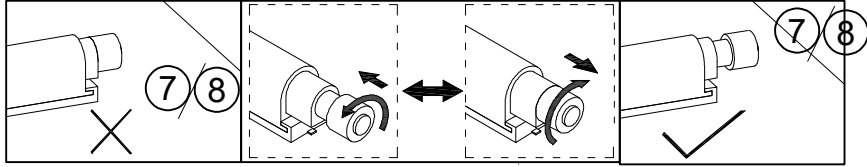

14

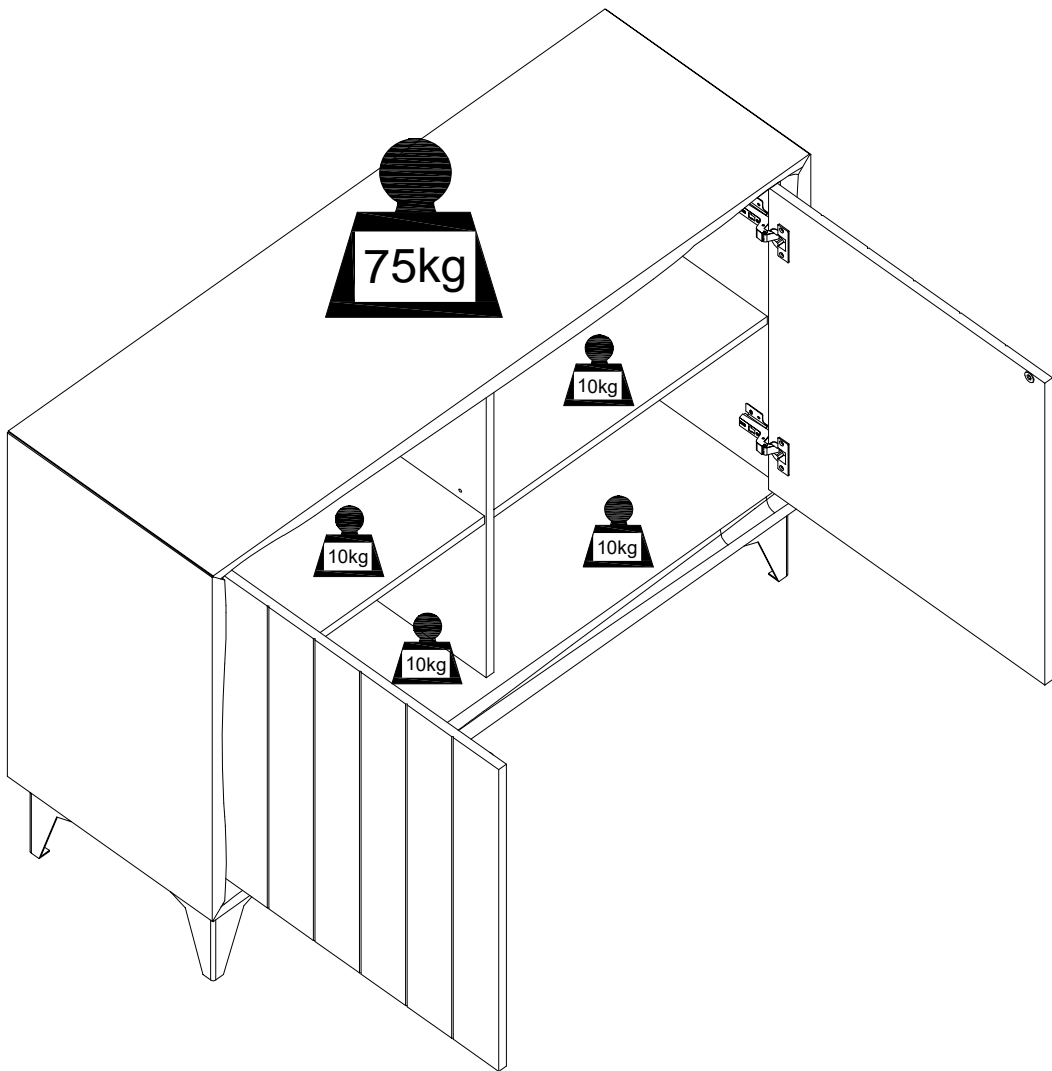

ES

<b>INSTRUCCIONES DE USO</b>	No fuerce nunca las conexiones. Vuelva a apretar los tornillos al cabo de unos días. Conserve el folleto de instrucciones. Este contiene información para pedir repuestos. Asegúrese de no sobrepasar el peso de carga máximo para un uso seguro. No desplace muebles cargados.
-----------------------------	---

<b>ALMACENAMIENTO Y MANTENIMIENTO</b>	Elimine cuidadosamente el polvo. Emplee un paño húmedo suave y limpio con agua jabonosa. No utilice productos de limpieza abrasivos ni disolventes.
---------------------------------------	---

PT

<b>INSTRUÇÕES DE UTILIZAÇÃO</b>	Nunca force as ligações. Volte a apertar os parafusos passados alguns dias. Guarde o folheto das instruções. Este contém informação para quando precisar de pedir peças em falta. Certifique-se de que não excede o peso máximo de carga para uma utilização segura. Não mova o mobiliário com carga.
---------------------------------	---

<b>ARMAZENAMENTO E MANUTENÇÃO</b>	Retire cuidadosamente o pó. Use um pano suave e ligeiramente embebido em água e detergente. Não use produtos de limpeza abrasivos nem solventes.
-----------------------------------	--